



List of Training Programs on Environmental Aspects of Sustainability

Sl.No	Title	Start Date	End Date	Participants
1	BIOPESTICIDES PRODUCTION AND ITS SIGNIFICANCE IN ENVIRONMENTAL SUSTAINABILITY	23-04-2025	23-04-2025	Faculty & Staff
2	MODELING SOIL ERODIBILITY FROM ENVIRONMENTAL COVARIATES USING MACHINE LEARNING FOR SOIL LOSS ASSESSMENT IN THE UPPER PONNAIYAR BASIN	13-04-2025	06-07-2025	Students
3	GENOTOXICITY TESTING FOR ENVIRONMENTAL MONITORING AND HUMAN HEALTH	09-02-2025	16-02-2025	Students
4	ENDING PLASTIC POLLUTION THROUGH INNOVATION, POLICY, AND PUBLIC ENGAGEMENT	11-06-2025	11-06-2025	Faculty & Students
5	CIRCULAR ECONOMY FOR COMBATING CLIMATE CHANGE- A MULTI-DIMENSIONAL PERSPECTIVE FROM THE WASTE MANAGEMENT INDUSTRY	12-03-2025	12-03-2025	Faculty & Students
6	WASTE TO ENERGY	07-03-2025	16-05-2025	Faculty & Students
7	CLIMATE CHANGE: MATERIALS & TECHNIQUES IN CARBON CAPTURE AND STORAGE	07-10-2024	09-12-2024	Students
8	CLIMATE CHANGE AND ENERGY OPTIONS FOR A SUSTAINABLE FUTURE BY PROF. DINESH KUMAR SRIVASTAVA. PANEL DISCUSSION ON BUILDING A SUSTAINABLE WORLD: INDIA'S CONTRIBUTION TO GLOBAL SDGS	28-09-2024	28-09-2024	Faculty & Students
9	AEROSOLS/PARTICULATE MATTER (PM): THEIR CLIMATE CONTRIBUTIONS AND HUMAN HEALTH IMPACTS OF INTEREST TO INDIA.	06-11-2024	06-11-2024	Students
10	AI FOR RESILIENT CITIES ENGINEERING SUSTAINABILITY AND CLIMATE HARMONY	08-02-2025	08-02-2025	Students
11	MICROPLASTICS AS AN EMERGING POLLUTANT	15-11-2024	15-11-2024	Faculty
12	ADVANCED FUNCTIONAL MATERIALS ON ENERGY AND HEALTHCARE APPLICATIONS	23-06-2025	27-06-2025	Faculty
13	SUSTAINABLE SMART CITIES: THE ROLE OF SMART GRIDS, EVS, AND GREEN HYDROGEN	05-05-2025	09-05-2025	Faculty
14	LOW-TEMPERATURE FUEL CELLS FOR ELECTROCHEMICAL PROPULSION: FUNDAMENTALS, MAJOR COMPONENTS, CELL FABRICATION AND REAL-TIME APPLICATIONS	12-03-2025	12-03-2025	Faculty
15	TECH FOR GOOD: BUILDING A SUSTAINABLE FUTURE THROUGH IT SOLUTIONS	07-03-2025	08-03-2025	Faculty & Students
16	ENERGY CONSERVATION WEEK	14-12-2024	18-06-2025	Faculty & Students
17	INTERACTIVE WORKSHOP ON ELECTROCHEMICAL TECHNOLOGIES: EMPHASIZING BATTERIES, SUPERCAPACITORS, AND FUEL CELLS	05-12-2024	06-12-2024	Faculty & Students
18	DESIGN AND DEVELOPMENT OF MICRO/SMART GRID INTENDED FOR SMART CITY DEVELOPMENT AND ENHANCING EMOBILITY	18-11-2024	23-11-2024	Faculty
19	THREE DAYS HANDS-ON TRAINING WORKSHOP ON CHARACTERIZATION OF ELECTRIFIED INTERFACES IN BATTERIES AND SUPERCAPACITORS	13-11-2024	15-11-2024	Faculty & Students
20	5-DAY WORKSHOP ON EMBEDDED SYSTEMS IN ELECTRIC VEHICLES	11-11-2024	15-11-2024	Faculty & Students
21	11TH ZERO ENERGY MASS CUSTOM HOME INTERNATIONAL CONFERENCE 2024	08-11-2024	09-11-2024	Faculty & Students
22	2-DAY HANDS ON WORKSHOP ON POWER AND ENERGY SIMULATION SOFTWARE WITH AI TECHNIQUES PESSAIT-2024	17-10-2024	18-10-2024	Faculty & Students
23	ENERGY ON THE MOVE: DISTRIBUTED WIND POWER	02-09-2024	06-09-2024	Students

Sl.No	Title	Start Date	End Date	Participants
24	HACKATHON ON SUSTAINABILITY IN CLIMATECH (48-HOUR HACKATHON)	09-09-2024	10-09-2024	Students, developers
25	NATIONAL WORKSHOP ON AI AND ENVIRONMENTAL SUSTAINABILITY	21-09-2024	21-09-2024	Students, faculty
26	ONLINE INTERNATIONAL CONFERENCE ON OPTIMIZING CLIMATE JUSTICE THROUGH TECHNOLOGICAL INTERVENTIONS	21-09-2024	21-09-2024	Students, faculty, policymakers
27	A FIVE-DAY HYBRID FDP ON CLEAN ENERGY TECHNOLOGIES FOR SUSTAINABLE DEVELOPMENT	30-09-2024	04-10-2024	Faculty, researchers, students
28	FOURTH INTERNATIONAL CONFERENCE ON SUSTAINABLE ENERGY SOLUTIONS FOR A BETTER TOMORROW (SESBT 2025)	09-01-2025	11-01-2025	Researchers, faculty, students
29	INTERNATIONAL CONFERENCE ON ADVANCEMENTS IN AI AND ML FOR SUSTAINABLE ENGINEERING	09-01-2025	10-01-2025	Students, researchers, industry experts
30	INTERNATIONAL CONFERENCE ON EMERGING MATERIALS FOR ENERGY AND SUSTAINABILITY (EMES 2025)	06-02-2025	08-02-2025	Researchers, students
31	CARBON CAPTURE, UTILIZATION AND STORAGE, AND DECARBONATION OF HARD-TO-ABATE INDUSTRIES	11-03-2025	11-03-2025	Students, researchers, industry experts
32	GREENATHON 2025 – A TECH AND SUSTAINABILITY IDEATHON	27-03-2025	27-03-2025	Students, innovators, faculty
33	CLASSROOM TO CLIMATE ACTION: ENGINEERING FOR IMPACT	04-04-2025	04-04-2025	Students, faculty
34	EXECUTIVE DEVELOPMENT PROGRAMME ON WASTE MANAGEMENT CONCEPTS, PRACTICES AND CASES	23-06-2025	27-06-2025	Students, faculty, industry professionals



VIT[®]

Vellore Institute of Technology
(Deemed to be University under section 3 of UGC Act, 1956)

VAIAL & SMEC with TLCE TRAINING PROGRAM DETAILS

Event type	FDP		
Title of the event	Biopesticides Production and its significanace in Environmental sustainability		
Date (From – To)	23.04.2025		
Time	2.15 pm to 5.30 pm		
Venue	TT-707		
No. of Participants	49		
Coordinator(s)	Emp. ID.	Faculty Name	Department
	10746	Dr.R.Vidya	VAIAL
	12449	Thundil Karuppa Raj R	SMEC, TLCE Director
Resource Person Name	Dr. G. Sivakumar		
Designation	Principal Scientist		
Organization Details	ICAR-National Bureau of Agricultural Insect Resources,		
Place	Bengaluru, Karnataka		
E-mail	sivakumarg.nbaii@gmail.com		
Mobile no.	+91 94811 90013		

R. Thundil Karuppa Raj R

Signature of the Coordinators

Signature of the Dean / Director
Director
Teaching Learning Centre of Excellence
VIT, Vellore - 632 014.

Brochure / Circular of the Event / Programme Schedule



VIT
Vellore Institute of Technology
(Deemed to be University under section 3 of UGC Act, 1956)



Teaching Learning Centre of Excellence (TLCE)

in association with

VIT School of Agricultural Innovations and Advanced Learning [VAIAL]

Cordially invites you for the

Faculty Development Programme [FDP]

on

Biopesticides Production and its significance in Environmental Sustainability

by

Dr. G Sivakumar

Principal Scientist, ICAR National Bureau of Agricultural Insect Resources, Bengaluru

Event Coordinators:

DR. VIDYA R, VAIAL

Dr. THUNDIL KARUPPA RAJ R, SMEC



Date : 23-April-2025

Time : 02.15 pm to 05.30 pm

Venue : TT 707

R. Thundil Karuppa Raj R

Director-i/c, TLCE

A REPORT ON

Biopesticides production and its significance in environmental sustainability

Agriculture has had to face the destructive activities of numerous pests like fungi, weeds and insects which have serious effect on food production as global crop yield is reduced by 20 to 40% annually due to plant pest and diseases. With the advent of chemical pesticides, this crisis was resolved to a great extent. But the over dependence on chemical pesticides and eventual uninhibited use of them has necessitated for alternatives mainly for environmental concerns. Biopesticides are certain types of pesticides derived from such natural materials as animals, plants, microbes and certain minerals. In commercial terms, biopesticides include microorganisms that control pests (microbial pesticides), naturally-occurring substances that control pests (biochemical pesticides), and pesticidal substances produced by plants containing added genetic material (plant-incorporated protectants). Biopesticides are employed in agricultural use for the purposes of insect control, disease control, weed control, nematode control and plant physiology and productivity. Microbial pesticides are also known as Biological Control Agents. In this category, the active ingredient is a microorganism that either occurs naturally or is genetically engineered. The pesticidal action may be from the organism itself or from a substance it produces. They offer the advantages of higher selectivity and less or no toxicity in comparison to conventional chemical pesticides. They suppress pests either by producing toxic metabolites specific to the pest, causing disease, preventing establishment of other microorganisms through competition, or various other modes of action. They suppress pest by producing a toxin specific to the pest causing a disease. Preventing establishment of other microorganisms through competition or other modes of action. Some of the pathogens may be quite common and are frequently the cause of epizootics in natural insect populations while others are rarely observed. Among various bio products *Bacillus thuringiensis* (Bt), *Trichoderma viride*, *Metarhizium spp.*, *Beauveria bassiana* and *Nuclear polyhedrosis virus* are popularly used in plant protection. Among them most successful insect pathogen used for insect control is the bacterium, *Bacillus thuringiensis* (Bt), which presently occupies about 3 per cent of the total insecticidal market. Each one of the strains produces different mix of toxins and specifically kills one or a few related species of insects (Bt subspecies *kurstaki* and *aizawai* for lepidopteran larvae and Bt subspecies *tenebrionis* for coleopteran larvae). Some of these strains are specific to mosquitoes (Bt subspecies *israelensis*). Among the insect viruses baculoviruses (Nuclear polyhedrosis virus, NPV and Granulosis virus, GV) are the most promising for insect control particularly of Lepidoptera and Diptera because of their specificity. NPVs have been successfully used for management of devastating pests like *Helicoverpa spp.* and *Spodoptera spp.* on cotton, fruit and vegetable crops in several countries. Entomopathogenic fungi like *Beauveria spp.*, *Metarhizium spp.*, *Lecanicillium spp.* and *Isaria spp.* have been developed as successful mycoinsecticides for various groups of insect pests. Several hundreds of commercial products of fungi, bacteria and viruses are available worldwide for the biological control of insect pests in agriculture and forestry. The growth rate of the bio-pesticide industry has been forecasted in the next 10 years at 15-20 per cent per annum in contrast to 2-3 per cent for chemical pesticides.

The main advantages of these biocontrol agents are their specificity to target pests, safety to the non-target organism, they do not cause ill effects on environment and human health and can be used against pests which develop resistance to the conventional insecticides, and they fit as ideal components in integrated pest management (IPM).

Geotagged photos of the event with caption and date

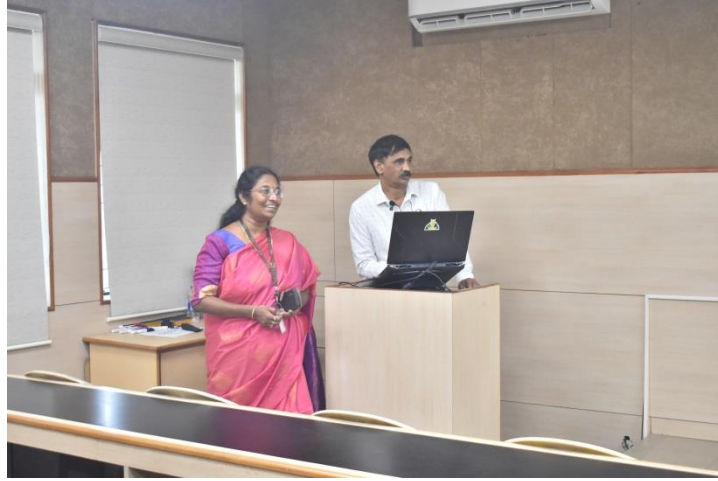



VIT[®]
Vellore Institute of Technology
(Deemed to be University under section 3 of UGC Act, 1956)

4th March 2025

Dr. R. Seenivasan
Director, International Relations

To
Mr Lucas Poix
Masters in water Science
University of Tours
France

Passport Number: 22CE37881;
Date of Passport Issue: 24.03.2022;
Date of Passport Expiry: 23.03.2032;
Date of Birth: 24.02.2003

Dear Lucas Poix

Greetings from Vellore Institute of Technology (VIT)!

I am pleased to invite Mr Lucas Poix, Masters in Water Science, University of Tours, France to visit School of Civil Engineering, VIT during 13th April 2025 to 6th July 2025.

We will make necessary arrangements for your local logistics and accommodation during your visit to VIT. Please let us know of your travel plans to help us make necessary arrangements.

This letter of invitation may be used to secure your visa from the Indian Embassy.

We look forward to your visit to VIT.

With regards

R. Seenivasan



Vellore - 632 014, Tamil Nadu, India; Phone: 91 - 416 - 2243091 (10 Lines) Fax: 91- 416 - 2243092

E-mail: registrar@vit.ac.in

www.vit.ac.in

Internship Project Theme: **Machine Learning Techniques for Soil Characterisation and Soil Loss Estimation**

Internship Project Title: **Modeling Soil Erodibility from Environmental Covariates Using Machine Learning for Soil Loss Assessment in the Upper Ponnaiyar Basin**

Intern: **Lucas Poix**; University: **University of Tours**; Duration: **[13-04-2025] to [06-07-2025]**

This document provides a concise overview of the critical research project being undertaken by our intern from the University of Tours. The internship's primary objective is to accurately quantify the soil erodibility factor (K) for the Upper Ponnaiyar Watershed, a key parameter in understanding and predicting soil erosion potential within this semi-arid catchment.

The project is structured to commence with a comprehensive data acquisition phase. This will involve detailed field sampling at 50 designated locations across the watershed to collect representative soil samples. Concurrently, rigorous laboratory analysis will be conducted to determine crucial soil properties, such as texture, organic matter content, and permeability, all of which directly influence soil erodibility. To further capture the nuanced topographical variations essential for erosion modeling, digital terrain models (DTMs) will be integrated into the dataset.

Following data acquisition, a robust analytical approach will be employed. Statistical methods, prominently including Pearson correlation analysis, will be utilized to meticulously examine the relationships among the collected soil, terrain, and hydrological variables. This statistical interrogation is vital for identifying the most influential factors governing erodibility in the study area. In parallel, the intern will apply advanced computational modeling and coding techniques to construct a predictive model. This model aims to simulate soil erosion processes and enhance our understanding of the K factor's dynamics.

The ultimate objective of this intensive research is to develop a reliable pedotransfer function. This function will serve as a practical tool, enabling the estimation of the K factor from readily measurable environmental parameters. Such a function holds significant potential for broader application, extending its utility to comparable semi-arid catchments facing similar soil degradation challenges.

This internship represents a valuable contribution to our ongoing efforts in environmental management and sustainable land use. The intern's focused work is expected to yield quantifiable insights into soil erodibility, providing a scientific basis for informed decision-making and conservation strategies within the Upper Ponnaiyar Watershed.



Internship contract N  50605
Academic year 2024/2025

• THE HIGHER EDUCATION INSTITUTION

Name of institution: **Universit  de Tours**

Address: B.P. 4301 37041 TOURS

Represented by (name of person signing contract): La Directrice, Sandrine DALLEY-CHOISY

Department/Faculty: **FACULTE SCIENCES ET TECHNIQUES**

Address (if different from address of institution): Parc Grandmont 37200 TOURS

Phone: 02 47 36 73 80

Fax:

email:

• THE HOST ORGANISATION

Name: **VELLORE INSTITUTE OF TECHNOLOGY**

Address: VIT University, Katpadi, Vellore TAMILNADU 632 014 INDIA

Phone: + 91 954 314 5123

Fax: 91-416-2243092

email: registrar@vit.ac.in

Represented by (name of person signing contract): Mr. Vignesh Rajkumar LAKSHMANAN

Name of department where internship will take place: School of Civil Engineering, VIT Vellore

Place of internship (if different from host organisation address): same

• THE INTERN STUDENT

Last Name: **POIX**First Name: **Lucas**Student ID: **22103414**

Gender: M

Date of Birth: 24/02/2003

Address: 49 Avenue de Bordeaux Appartement 224 Jou -l s-Tours 37300 JOUE-LES-TOURS FRANCE

Phone: 0626572574

Mobile: 0626572574

email: lucas.poix@etu.univ-tours.fr

Title of course taken at the higher education institution and hourly volume

M1 Sciences de l'eau parcours hydrosyst mes et bassins versantsHourly volume of internship: **More than 200 hours.**Subject of Internship: **Soil Erodibility and Sediment fingerprinting at Upper Ponnaiyar Watershed**

Dates of internship: From 13/04/2025 To 06/07/2025

Corresponding to **480 hours** of actual presence in the host organisation
and corresponding to **3 month(s) 2 day(s) and 4 hour(s)**

Comments:

Supervision of the intern provided by the higher education institution**The Educational Institution:**Last Name: **GROSBOIS**First Name: **Cecile**

Phone:

email: cecile.grosbois@univ-tours.fr

The Host Organisation:Last Name: **Lakshmanan**First Name: **Vignesh Rajkumar**

Phone: +91 9566051611

email: vigneshrajkumar.l@vit.ac.in

Supervisor's title: Assistant Professor Senior

Healthcare insurance office to be contacted in the event of an accident (place of student's residence unless otherwise indicated):
Caisse primaire d'assurance maladie (CPAM) de Sa ne-et-Loire - 71022 M con Cedex 9

Based on the French Code of Public Health, in particular articles L. 3131-1 and articles thereafter;
 Based on the French Code of Education, in particular articles L. 124-1 to L. 124-20, L. 612-11 and D. 124-1 to D. 124-9; D714-21 and following;
 Based on the French Code of Social Security, in particular articles L. 242-4-1, L. 412-8 and D. 242-2-1;
 Based on the French Code of Labour in particular articles L. 1221-13 and D. 1221-23 and articles thereafter;
 Based on the French Decree n° 2020-1257 of October 14, 2020;
 Based on the French national protocol TO ENSURE THE HEALTH AND SAFETY OF EMPLOYEES FACING THE COVID-19 EPIDEMIC, October 29, 2020;
 Based on the consultation of the Training and University Life Commission and the opinion of the establishment's Board of Directors.

Requirements:

Internships in France: Given the exceptional circumstances due to the Covid 19 pandemic, it is understood between the parties that they will have verified beforehand that the missions entrusted to the intern lend themselves to face-to-face and / or remote work and that they have the appropriate equipment.

The tutors check the possibility of use by the parties of adequate communication tools.

The internship can only be carried out face to face and in strict compliance with all health, safety and hygiene provisions.

It is understood between the parties that in the event of total confinement, the internship will automatically switch to a remote internship or be the subject of a suspension by amendment if a remote internship is not possible.

Internships for medical and paramedical students are subject to specific provisions.

A medical examination will be automatically organised for all students exposed to a particular risk during their internship.

Contact preventive medicine:

Internships outside France: Given the exceptional circumstances due to the Covid 19 pandemic, it is understood between the parties that they will have verified beforehand that:

- If the internship takes place face-to-face, specific repatriation insurance is taken out by the intern for the return, in the event of confinement or other circumstances making it impossible to continue the internship.
- The missions entrusted to the trainee are suitable for face-to-face and / or remote work and that they have the appropriate equipment.

The tutors check the possibility of use by the parties of adequate communication tools.

The internship can only be carried out face-to-face in strict compliance with all health, safety and hygiene provisions applicable in the host organisation.

It is understood between the parties that in the event of confinement, the internship will automatically switch to a remote internship or be the subject of a suspension by amendment if a remote internship is not possible, in addition to the repatriation arrangements.

The French trainee hereby agrees, before their departure, to register on ARIANE:

<https://pastel.diplomatie.gouv.fr/fildariane/dyn/public/login.html>

Any trainee infected with Covid19 during their internship must comply with the conditions mandated in the host country, in particular in terms of quarantine. The French Educational Institution cannot be required to repatriate the trainee.

A medical examination will be automatically organised for all students exposed to a risk during their internship.

Contact of preventive medicine:

Emergency contact: (other than the trainee):

Article 1 - Purpose of the contract

The present contract governs the relationship between the host organisation (company, public agency, association...), the higher education institution and the intern, taking into account the exceptional circumstances due to COVID 19.

Article 2 - Objective of internship

The objective of the internship is to enable the student to implement the theoretical and methodological tools acquired during the course of study, to identify skills and to consolidate career goals. The internship aims to prepare the student to enter working life with a better understanding of the host organisation. The internship forms part of the student's personal and professional training and development and is part of the course curriculum.

The internship programme is determined by the higher education institution and the host organisation according to the general curriculum of training offered.

Duties to be carried out:

- Field visit- Sampling sediment cores and Soil- Bathymetric surveying- Soil analysis- Soil erodibility map- Identification of sampling location based on soil classification and accessibility- Report writing

Skills to be acquired or developed:

- Bathymetric Survey - Sediment Coring - Soil analysis procedure and classification - GIS for mapping.

Article 3 - Practical terms of internship

The maximum weekly amount of time the intern will be present at the workplace is **40.00** hours, on a **Full time basis**.

It is forbidden to assign to the trainee, tasks that are dangerous to his health or safety.

If the intern must be present at the host organisation at night, on a Sunday or on a bank holiday, the organisation must indicate these special cases here:

Article 4 - Hosting and supervision of the intern

The intern is supervised by the teacher designated in this agreement as well as by the department of the institution in charge of internships.

The internship tutor designated by the host organisation in this agreement, is responsible for monitoring the intern and optimising the conditions for carrying out the internship in accordance with the pedagogical stipulations defined.

Framework of supervision: (visits, telephone appointments, etc.)

.....
If sanitary conditions allow, the trainee is authorised to return to his educational establishment during the internship to follow courses explicitly requested by the program, or to participate in meetings (the dates of which are brought to the attention of the host organisation by the establishment). The host organisation may authorise the intern to travel, with the exception of internships abroad.

Any difficulty that arises in carrying out and running the internship, whether noted by the intern or by the internship tutor, must be brought to the attention of the teacher and the educational institution in order to be resolved as quickly as possible.

Article 5 - Remuneration - Benefits in kind - Reimbursement of expenses

In France, where the duration of the internship period is longer than two consecutive months or not, the latter must be the subject of a gratuity, except in the case of special rules applicable in certain French overseas communities and for courses covered by Article L4381-1 of the French Public Health Code.

Remuneration is fixed at 15% of the hourly social security limit defined in accordance with article L.241-3 of the French Code of Social Insurance. A branch collective agreement or a professional agreement may define an amount higher than this rate.

The remuneration due by a body governed by public law may not be combined with remuneration paid by that body during the period concerned.

The remuneration shall be due without prejudice to the reimbursement of the costs incurred by the intern to carry out his internship and the benefits, if any, offered for food, accommodation and transport.

When the duration of the internship is less than or equal to two months and takes place in a public or private enterprise or an association on French territory, the student may receive remuneration.

In the event of suspension or termination of this agreement, the amount of the remuneration due to the intern student shall be prorated according to the duration of the internship period.

The duration of the remuneration shall be assessed taking into account this agreement and any amendments thereto, as well as the number of days the intern student is actually present in the organisation.

Amount of remuneration fixed at : 0

Article 5a - Access to Employee Rights - Benefits

In France - (Body governed by private law in France except in the case of special rules applicable in certain French overseas communities):

The intern student benefits from the protections and rights mentioned in articles L.1121-1, L.1152-1 and L.1153-1 of the French Employment Code, under the same conditions as the employees.

The intern student shall have access to the company restaurant or restaurant vouchers provided for in Article L.3262-1 of the French Employment Code, under the same conditions as the employees of the host organisation. It also benefits from the transportation costs provided for in article L.3261-2 of the same code.

The intern student shall have access to the social and cultural activities referred to in Article L.2323-83 of the French Employment Code under the same conditions as employees.

The host organisation undertakes to comply with the national protocol of release from lockdown and, where appropriate, the published job descriptions.

Article 5b - Access to Employee Rights - Benefits

In France - (Body governed by public law in France, except in the case of special rules applicable in certain French overseas communities):

Journeys made by the intern student of a public law body between their home and their place of internship are taken over under the conditions set by French decree no. 2010-676 of 21 June 2010 introducing a partial charge for the price of subscription tickets corresponding to the trips made by public servants between their habitual residence and their place of work.

The trainee who is admitted to a body governed by public law and who carries out a mission in this context shall be reimbursed for temporary travel expenses in accordance with the regulations in force.

The place of administrative residence shall be the place where the internship takes place, specified in this internship contract.

Article 6 - Social insurance

The student remains affiliated with his/her national healthcare system throughout the duration of the internship and will have student status. In the case of internships undertaken abroad, the French national healthcare system must be informed and verification must be received from them prior to the departure of the student. The following clauses are applicable subject to compliance with the legislation of the host country and legislation governing the type of host organisation.

6.1 - Remuneration of up to 15% of the hourly social security ceiling

In France, the remuneration is not subject to social contributions.

The intern student benefits from the legislation on accidents at work under the student scheme of Article L.412-8 2° of the French Code of Social Insurance.

In the event of an accident or occupational disease occurring to the intern student either during activities in the organisation, or during the journey, or on the premises rendered useful for the purposes of the internship and for medical students, in dental surgery or pharmacy who do not have a hospital status during the course carried out under the conditions provided for in b of the 2nd article L.412-8 of the French Code of Social Insurance, the host organisation sends the declaration to the « Caisse Primaire d'Assurance Maladie » or the competent sickness fund (see address on page 1) mentioning the educational institution as employer, with a copy to higher education institution.

6.2 - Remuneration in excess of 15 % of the hourly social security ceiling

In France, social contributions are calculated on the difference between the amount of the remuneration and 15% of the social security hourly ceiling.

In the event of an accident occurring to the intern student either during activities in the organisation, or during the journey, or at places made useful for the purposes of his internship, the host organisation shall make all necessary representations and inform the higher education institution as soon as possible.

6.3 - Health Insurance for interns working abroad

1) Protection Coverage originating in the French students' coverage framework

- for internships within the European Economic Area (EEA) conducted by nationals of a State of the European Union or of Norway, Iceland, Liechtenstein or Switzerland, or of any another State (in the latter case this provision shall not apply for internships in Denmark, Norway, Iceland, Liechtenstein or Switzerland), students must apply for a European Health Insurance Card (EHIC).

- for internships in Quebec by students of French nationality, students must request form SE401Q (104 for internships at companies, and 106 for university internships);

In all other cases:

- students who incur medical expenses may be reimbursed by their complementary insurance company serving as their student French national healthcare provider, upon their return and upon presentation of receipts. Reimbursement shall then be carried out on the basis of French healthcare rates. Significant differences may exist between the costs incurred and the French rates serving as the basis for reimbursement. It is strongly advised that students take out specific additional health insurance coverage valid for the country in question and for the duration of their internships. The insurance company is of their choice (student's or parent's complementary insurance, ad hoc private company, etc.), or, possibly, after checking the extent of the guarantees proposed, from the host organisation if it provides health coverage to interns under local law (see item 2 below).

2) Social welfare protection from the host organisation

By checking the appropriate box below, the host organisation indicates whether it provides health insurance coverage to the intern under local law:

YES: This coverage is in addition to the maintenance abroad of rights granted under French law.

NO: coverage is thus exclusively provided from the rights granted under the French student's international coverage framework.

If neither box is checked, item 6.3-1 shall apply.

6.4 - Workplace Accident Coverage for interns abroad

1) In order to benefit from French legislation providing coverage for workplace accidents, this internship must:

- have a duration not exceeding six months, including any extensions;
- not include any remuneration that may tend to qualify for rights to workplace accident protection in the host country; compensations or stipends are acceptable, up to the limit of 15% of the hourly ceiling for social security (see point 5), and subject to approval by the Primary Health Insurance Agency of a request for the maintenance of such rights;
- take place exclusively within the organisation signing this agreement;
- take place exclusively in the above-mentioned foreign host country.

When these conditions are not met, the host organisation undertakes to contribute to the intern's welfare protection and make the necessary declarations in case of workplace accidents.

2) The workplace accident statement is the responsibility of the educational institution, which must be informed of such events in writing within 48 hours by the host organisation.

3) The coverage concerns accidents occurring:

- within the internship location and during internship working hours,
- on the normal commute to and from the intern's residence in the foreign country and the internship location,
- as part of an assignment provided by the intern's host organisation and the intern student, subject to the maximum duration of the training period fixed by law (6 months).
- during the first trip from his home to his place of residence during the internship (travel on the internship start date),
- during the final return trip from his residence during the internship, to his home.

4) In the event that one of the conditions set forth in section 6.4-1 is not satisfied, the host organisation commits to cover the intern for the risks of workplace accidents, travel accidents, and occupational disease, and provide all the necessary statements of coverage.

5) In all cases:

- if the student is the victim of a workplace accident during their internship, the host organisation must immediately notify the educational institution of the accident,
- if the student performs limited assignments outside the host organisation or the internship country, the host organisation must take all necessary steps to provide him/her with the appropriate insurance.

Article 7 - Civil liability and insurance

The host organisation and the student declare that they have civil liability coverage.

Regardless of the nature of the internship and the destination country, the intern agrees to obtain coverage for him/herself by way of a general insurance policy (medical repatriation, legal assistance, etc) and a personal accident insurance policy.

If the host organisation provides the intern with a vehicle, it is the responsibility of the host organisation to confirm beforehand that the vehicle insurance policy covers use of the vehicle by a student.

When the student uses his/her own vehicle or a vehicle loaned by a third party within the framework of the internship, the student expressly agrees to declare this use to the insurer of the said vehicle, and if required, to pay the relevant premium.

Article 8 - Conduct

During the internship, the student must comply with the rules and guidelines of the organisation, brought to his/her attention before the start of the internship, in particular in relation to working hours, and health and safety regulations in the host organisation. The student intern shall report any failure to his/her host organisation AND his higher education institution.

Disciplinary procedures may only be determined by the HE institution. In the event of a breach of discipline, the host organisation should inform the academic tutor and the higher education institution of the breach(es) and provide the constitutive elements.

In the event of a particularly serious breach of discipline, the host organisation reserves the right to terminate the internship while respecting the clauses fixed in Article 9 of the present contract.

Article 9 - Leave of absence - Interruption of internship

In France (except in the case of special rules applicable in certain French overseas communities or in bodies governed by public law), in the event of pregnancy, paternity or adoption, the student intern shall be granted leave and absence authorisations of a duration equivalent to that laid down for employees in articles L.1225-16 to L.1225-28, L.1225-35, L.1225-37, L.1225-46 of the French Employment Code.

For internships with a duration of more than two months and within the maximum duration of 6 months, leave or leave of absence are possible.

Number of days of authorised leave or terms of leave and absences during the probationary period

3

For any other temporary interruption of the internship (illness, unjustified absence, etc.) the host organisation informs the higher education institution by mail/email.

Any interruption of the internship shall be reported to the other parties of the contract and to the academic tutor. A validation procedure is set up by the higher education institution, if necessary. In case of agreement of the parties to the internship contract, a postponement of the end of the internship is possible in order to allow the completion of the total duration of the internship initially planned. This postponement will be the subject of an amendment to the internship agreement.

An amendment to the internship agreement may be drawn up in the event of an extension of the internship period at the joint request of the host organisation and the student intern, subject to the maximum duration of the training period fixed by law (6 months).

Article 10 - Duty of circumspection and nondisclosure

The duty of circumspection is absolute. In this respect, the student intern agrees that in no circumstances will he use information he has gathered or obtained, including the internship report, for the purpose of publication or communication to third parties, without prior consent from the host organisation. In addition to the duration of the internship, this continues to apply after the internship has ended. The student agrees not to take, keep, or make a copy of any document or software belonging to the host organisation, regardless of its nature, without the consent of the host organisation.

Note: Within the framework of nondisclosure, the host organisation can request a restriction on the distribution of the report and even the withdrawal of certain elements of highly confidential information.

Those who have knowledge of the information contained in the report are restricted by professional confidentiality not to use or disclose any information contained therein.

Article 11 - Intellectual property

In France, in accordance with the Intellectual Property Code, if the work undertaken by the intern results in the creation of a piece of work protected by copyright or industrial property (including software), and if the host organisation wishes to use the work and the student consents to this, a contract should be drawn up and signed by the intern (author) and the host organisation.

The contract should notably include the extent of transferred rights, the conditions of exclusivity, the destination of the work, the resources used and the duration of the transfer of rights as well as the total remuneration owed to the student in relation to the transfer of rights, if applicable. This clause also applies in the case of internships carried out in public institutions.

Article 12 - End of the internship - Report - Evaluation

1) Internship certificate: At the end of the internship, the host organisation will provide the intern with an internship certificate (see appendix), stating the duration of the internship and for France, the amount of remuneration received. The trainee must produce this certificate in support of his possible application for entitlement to the general pension insurance scheme provided for in Art. L.351-17 of the Social Insurance Code.

2) Quality evaluation of the internship: At the end of the internship, the parties to this internship contract are invited to make an assessment of the quality of the internship. The student intern shall send a document to the competent department of the higher education institution in which they assess the quality of the reception received within the host organisation. This document is not taken into account in its evaluation or in obtaining the diploma or certification.

3) Evaluation of the student's activity: At the end of the internship, the host organisation will complete an evaluation form in relation to the performance of the intern (see appendix) which should be returned to the academic tutor of the higher education institution.

4) Educational Assessment Procedures: **Rapport de Stage, Evaluation Ecrite et Soutenance**





5) The host organisation tutor or any other member of the host organisation required to visit the HE institution as part of the preparation, implementation or validation of the internship may not claim reimbursement or compensation from the higher education institution.

Article 13 - Applicable law - Courts of competent jurisdiction

The present contract is governed exclusively by French law. Any dispute which cannot be settled out of court will be submitted to the competent French jurisdiction.

AT Tours

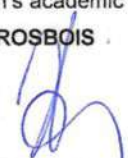
DATE 18/03/2025

The Host Organization	The Educational Institution
Signatory of the Internship agreement (<i>Signataire de la convention</i>): M. P. Saravanakumar <i>MPS</i> Dean School of Civil Engineering VIT Vellore Institute of Technology (VIT) Vellore - 632 014, TN, India	On behalf of the President of the Université de Tours, The Director of the Department: Sandrine DALLET-CHOISY  
The Internship supervisor (<i>Le tuteur de stage</i>): Vignesh Rajkumar LAKSHMANAN 	The Intern's academic advisor (<i>L'Enseignant référent</i>): Cecile GROSBOIS 
The Intern (<i>L'Etudiant</i>): (and legal representative if any) Lucas POIX 	

Appendices:

- 1) Internship certificate
- 2) Other documents, if appropriate

09th February 2025 to 16th February 2025

Jointly Organized by
Dept. of Biomedical Sciences,
School of Bio-Sciences and Technology, VIT Vellore
and

Instituto de Investigaciones Biológicas Clemente Estable (IIBCE), Uruguay

Beneficiaries:
UG / PG/ Research

ABOUT VIT:

Vellore Institute of Technology was founded in 1984 as Vellore Engineering College by the Founder and Chancellor Dr. G. Viswanathan. University status was conferred in 2001 by MHRD Govt. of India in recognition of its excellence in academics, research and extracurricular initiatives. Ranking & Accreditation Vellore Institute of Technology (VIT) has emerged as one of the best institutes in India and is aspiring to become a global leader. Quality in teaching-learning, research and innovation makes VIT unique. Engineering and Technology subject areas of VIT are the 212th best in the World and the 9th best in India, and Ten subjects of VIT are within the top 500 in the world (as per QS World University Rankings by Subject 2024) The 8th best University, the 11th best research institution and the 11th best engineering institution in India (NIRF Ranking, Govt. of India 2023) Ranked among the top 601-800 universities of the world (THE World University Ranking 2024) NAAC Accreditation with A++ grade (3.66 out of 4) The 163rd-best Institution in Asia (QS - Asia University Rankings 2024)

ABOUT SBST:

The School of Bio Sciences and Technology consists of four departments namely Biotechnology, Integrative Biology, Bio-Sciences and Bio-Medical Sciences headed by well-trained professors. The school offers an undergraduate (B.Tech. Biotechnology) and six Postgraduate (M.Sc. and M. Tech.) programme. It also offers Integrated Ph.D. and Ph.D. programme. The priority of the SBST is developing entrepreneurship skills and mentoring students to become future scientists for the improvement of humanity. Our efforts are strengthened by collaboration with national, international Universities and multinational companies. Consultancy research and commercialization of products at the University are undertaken as a part of the program. The school houses excellent infrastructure and well-trained faculty members which makes SBST one among the top ten Bio School in the country.

ABOUT THE DEPARTMENT OF BIO-MEDICAL SCIENCES:

The Department of Bio-Medical Sciences under The School of Bio-Sciences and Technology commits to the Academia and research. It offers 2 Postgraduate courses namely M.Sc. Applied Microbiology and M.Sc. Biomedical Genetics. The course of Biomedical Genetics aides the students with the basic understanding and trailing till the present day advancements in the field. It adds on the skillset for Clinical and laboratories needed in this field. It fosters strong collaborations with national and international institutions, multinational companies, and visiting scientists, enhancing interactions between academia and the biotech industry. The two-year M.Sc. in Biomedical Genetics provides a comprehensive understanding of disease genetics and develops clinical and laboratory skills. Students can choose a specialization in Genetic Counselling, which includes clinical rotations in hospitals

Chairperson
Dr. Suneetha V
Dean, SBST

Convenor
Dr. Radha Saraswathy
Professor HAG,
Dept. of Biomedical Sciences, SBST

RESOURCE PERSONS:

- Dr. Wilner Martínez-López, MD, PhD
Epigenetics and Genomics Instability
Laboratory, Instituto de Investigaciones
Biológicas Clemente Estable, Montevideo –
Uruguay
- Dr. Radha Saraswathy
Dept of Biomedical Sciences,
SBST, VIT

COURSE OBJECTIVES:

- To relate the importance of genotoxicity and Epigenetic toxicity to environmental monitoring and human health.
- An opportunity to obtain extensive, basic theoretical knowledge and insights in this field.
- To interpret the action of mutagenic substances and carcinogens with long-term irreparable consequences.
- To illustrate the fundamental and advanced techniques for genotoxic testing and assessment.

COURSE OUTCOMES:

- Have competence in the practical skills in handling basic laboratory processes for analysis and genotoxicity testing.
- Understand various aspects of environmental monitoring techniques.
- Design/develop an idea for identifying the cause or solution for protecting Human health.

THEMES/TOPICS:

1. Genotoxicity and Epigenetic toxicity
2. Human health
3. Genotoxicity biomarkers
4. Epidemiological studies
5. Recommendations and implementation

Total course duration: 30 hours

LIST OF CHALLENGING EXPERIMENTS:

- EXPT 1 Comet assay in human peripheral blood mononuclear cells
- EXPT 2 Comet assay in human cell lines
- EXPT 3 Cytokinesis block micronucleus assay in human peripheral blood mononuclear cells
- EXPT 4 Lymphocyte culture for chromosomal aberrations
- EXPT 5 Sister chromatid exchanges
- EXPT 6 Determining cell survival with different dyes
- EXPT 7 Cytokinesis block micronucleus assay in exfoliated buccal cells
- EXPT 8 γ H2AX immunofluorescence staining

DATE: 09 February 2025 to 16 February 2025
VENUE: 120TT, Biomedical Genetics Research Laboratory
REGISTRATION FEE DETAILS: Rs.500/- (Inclusive of GST)
REGISTRATION LINK: <https://events.vit.ac.in/>

Course Material will be provided to all. Students with 75% attendance and 50% Marks in the evaluation will receive the certificate.



SCHOOL OF BIOSCIENCES & TECHNOLOGY

**VALUE ADDED / GUEST LECTURE / SEMINAR / WORKSHOP /
SYMPOSIUM / CONFERENCE / TRAINING PROGRAM DETAILS**

Event type	Value Added Program (VAC2002)		
Title of the event	Genotoxicity Testing for Environmental Monitoring and Human Health		
Date (From – To)	9 th February 2025 – 16 th February 2025		
Time	8.30AM to 6.00PM		
Venue	113TT; 120TT; Kamaraj Auditorium TT and 209SMV		
No. of Participants	52		
Coordinator(s)	Emp. ID.	Faculty Name	Department
	10416	Radha Saraswathy	SBST
		Dr Wilner Martinez Lopez	Adjunct Faculty
Resource Person Name	Dr. Wilner Martinez Lopez and Dr Radha Saraswathy		
Designation	Adjunct Faculty SBST and Prof HAG		
Organization Details	IIBCE, Uruguay and VIT		
Place	VIT		
E-mail	radhasaraswathy@vit.ac.in		
Mobile no.	9443328424		

Saraswathy
Signature of the Coordinator
(Dr. Radha Saraswathy)
Emp ID 10416

[Signature]
Signature of the Dean / Director
Dean
School of Bio Sciences & Technology (SBST)
Vellore Institute of Technology (VIT)
(Deemed to be University under section 3 of UGC Act, 1956)
Vellore – 632 014, Tamil Nadu, India

Report on Genotoxicity Testing for Environmental Monitoring and Human Health VAC2002

Brief write-up

The VAC2002 started on 9th February 2025 in 209SMV at 9.00AM. Dr Wilner gave an introduction of the importance of genotoxicity and Epigenetic toxicity to environmental monitoring and human health. This course was an opportunity to obtain extensive, basic theoretical knowledge and insights in this field. The hands-on sessions for the students were to interpret the action of mutagenic substances and carcinogens with long- term irreparable consequences. Also the fundamental and advanced techniques for genotoxic testing and assessment were carried out.

The course materials and the protocols were given to all registered participants. The students' feedback session was held on 16th February, the last day of VAC2002 and they very much appreciated this hands-on and was very happy with resource person as he was approachable and were handling basic laboratory processes for analysis and genotoxicity testing. They learnt various aspects of environmental monitoring techniques. They got an idea for identifying the cause or solution for protecting Human health. They took the QUIZ and thanked the resource persons.

Although we aimed to complete the course in 30 hrs but the students performed more experiments later as well exceeding 40 hrs. Students (51 registered) were from MSI, BBT, MSM, MBT, MSG and Research scholars. We had to limit the registration as this course was hands-on. This VAC2002 was very much encouraged by Dr. V. Suneetha, Dean, SBST from the initiation till the end. Thank you Madam.

Resource Persons briefing the VAC2002 on 9th Feb 2025 @ 209SMV



Course code	VAC2002	
Course Title	Genotoxicity testing for Environmental monitoring and Human health	
School / Centre:	SBST	
Beneficiaries: UG / PG/ Research	UG/PG	
Course objective:	<p>To relate the importance of genotoxicity and Epigenetic toxicity to environmental monitoring and human health.</p> <p>An opportunity to obtain extensive, basic theoretical knowledge and insights in this field.</p> <p>To interpret the action of mutagenic substances and carcinogens with long-term irreparable consequences.</p> <p>To illustrate the fundamental and advanced techniques for genotoxic testing and assessment.</p>	
Course outcome:	<p>Have competence in the practical skills in handling basic laboratory processes for analysis and genotoxicity testing.</p> <p>Understand various aspects of environmental monitoring techniques.</p> <p>Design /develop an idea for identifying the cause or solution for protecting Human health.</p>	
S. No.	Topic	Duration (hours)
1	Genotoxicity and Epigenetic toxicity - Significance and Use in Environmental Monitoring- Public health concerns. A brief overview of the main tests, pitfalls and regulatory framework. Genotoxicity testing: an introduction to the different test systems. Regulatory aspects (OECD, ICH, REACH)	2
2	Human health -The application of the assays to monitor the exposure of humans and biota. Long-term effects to affect human and environmental health. Occupationally and Environmentally exposed population. Case studies.	3
3	Genotoxicity biomarkers - Chromosomal aberrations (CA), micronuclei (MN), sister chromatid exchanges (SCEs) and comet assay (CO). Early detection of genetic damage. Epigenetic Signatures as Biomarkers of Exposure. Genotoxicity and Genetic damage, Repair.	3
4	Epidemiological studies - Study of populations exposed to toxic agents, high risk groups. The role of epigenetics in genetic and environmental epidemiology. Interpreting data, risk assessment and limiting the risks, monitoring of exposure.	2
5	Recommendations and implementation to protect human populations and the environment - Reducing the environmental pollutants that affect human health, Establishing a monitoring protocol. Removal and control the sources of pollution. Educate the community.	2
	Total course duration	12

S. NO	List of Challenging Experiments	Duration (hours)
EXPT 1	Comet assay in human peripheral blood mononuclear cells	5
EXPT 2	Comet assay in human cell lines	5
EXPT 3	Cytokinesis block micronucleus assay in human peripheral blood mononuclear cells	5
EXPT 4	Lymphocyte culture for chromosomal aberrations	5
EXPT 5	Sister chromatid exchanges	5
EXPT 6	Determining cell survival with different dyes	5
EXPT 7	Cytokinesis block micronucleus assay in exfoliated buccal cells	5
EXPT 8	Karyotyping	4
EXPT 9	Western blotting	4
EXPT 10	γ H2AX immunofluorescence staining	5
	Total Laboratory hours	48
	Total	60
	Date of Board of Studies in which it is recommended :	
	Date of the Academic Council in which it is approved:	



VIT
Vellore Institute of Technology
(Deemed to be University under section 3 of UGC Act, 1956)

Center for Clean Environment

VALUE ADDED / GUEST LECTURE/ SEMINAR / WORKSHOP / SYMPONIUM / CONFERENCE / TRAINING / PROGRAM DETAILS

Event Type	Online Seminar		
Title of the Event	Ending Plastic Pollution through Innovation, Policy, and Public Engagement		
Date (From – To)	11th June 2025		
Time	10.00 am to 12.30 pm		
Venue	Online		
No. of participants	114		
Coordinator(s)	Emp. ID.	Faculty Name	Department
	21240	Dr. Monali Priyadarshini	Center for Clean Environment
	19747	Dr. Greeshma O	Center for Clean Environment
Resource Person Name	Dr. Ruby Makhija		
Designation	Founder, Why Waste Wednesdays Foundation, New Delhi		
Organization Details	Email: drrubymakhija@gmail.com		
Place	Dr. M. Dwarakanath		
Email:	Chairman, SEIAA, Government of Pondicherry, Visiting Professor, PSGCAS & PSGIM, Coimbatore, Tamil Nadu Email: dwarak98@gmail.com		

Signature of Coordinator

Signature of the Director

Director
Centre for Clean Environment
Vellore Institute of Technology (VIT)
(Deemed to be University under section 3 of the UGC Act, 1956)
Vellore - 632 014, TN, India.

Expenditure/ Revenue Details of the Event

Honorariums for the speaker

SL No.	Particulars	Topics	Rs/-
a)	Dr. Ruby Makhija	Plastic: From A Miracle Material to a Menace	3000/-
b)	Dr. M. Dwarakanath	Plastics: Sustainable Way of Management: Options, Trends, Future	3000/-
	Total Expenditure Cost		6000/-

There was no contribution from registration fees, as the event was conducted without any registration cost to encourage wider participation from students, research scholars, faculty members, and industry professionals, in alignment with the spirit of World Environment Day 2025.



Signature of Coordinator



Signature of the Director

Director
Centre for Clean Environment
Vellore Institute of Technology (VIT)
(Deemed to be University under section 3 of the UGC Act, 1956)
Vellore - 632 014, TN, India.

A REPORT ON
ONLINE SEMINAR ON
“Ending Plastic Pollution through Innovation, Policy, and Public Engagement”
11TH JUNE, 2025

Centre for Clean Environment, VIT, Vellore organized an online seminar on “*Ending Plastic Pollution through Innovation, Policy, and Public Engagement*” on 11th June, 2025 in connection with World Environmental Day 2025. In this seminar Dr. Ruby Makhija, Founder, Why Waste Wednesdays Foundation, New Delhi and Dr. M. Dwarakanath, Chairman, SEIAA, Government of Pondicherry, delivered lectures on topics related to the theme of World Environment Day 2025.

Dr. S. Shantha kumar, Professor & Director, Centre for Clean Environment (CCE), delivered the inaugural address. A total of 114 participants attended the seminar, including 87 from various external institutions and 27 from VIT Vellore. The attendees represented institutes from Tamil Nadu, Kerala, and other states. Dr. Ruby Makhija, Founder of Why Waste Wednesdays Foundation, New Delhi, delivered a lecture on the topic “*Plastic: From a Miracle Material to a Menace.*” Dr. M. Dwarakanath, Chairman, State Environmental Impact Assessment Authority (SEIAA), Government of Pondicherry, delivered a lecture on “*Plastics: Sustainable Way of Management: Options, Trends, Future.*”

Both lectures were well appreciated by the participants and significantly enhanced their understanding of the growing challenges of plastic pollution, its impact on ecosystems, human health, and climate change, as well as the importance of sustainable plastic management strategies, including policy, innovation, and public engagement. The attendees gained a deeper understanding of the environmental and health impacts of plastic waste, the urgency of reducing plastic consumption, and the need for innovative, policy-driven solutions. Overall, the seminar contributed to raising awareness about the challenges posed by plastic pollution and the importance of collective action for a cleaner and more sustainable environment.

Attendance of External Members

Sl. No.	Name	Organization
1	Dr.G.Prabhakaran	Siddharth Institute of Engineering & Technology
2	KUDUMALA GANGA TEJESWAR REDDY	SIDDHARTH INSTITUTE OF ENGINEERING AND TECHNOLOGY
3	B.Raghavendra babu	Sardar Swaran Singh National Institute of Bioenergy, Kapurthala, Punjab
4	POOJARI ISWARYA	Siddharth institute of engineering and technology
5	Alok Kumar	Department of Zoology, Patna University
6	Divya Kumar Manglam	Patna University
7	Dr. N. A. Koujageri	KLE'S SVS Bellubbu Arts & Commerce College, Saundatti
8	Sneha Singh	Banasthali Vidyapith
9	Pratik Goyal	Nirmal Vasundhara Private Limited
10	Nivedita Shah	Hemvati Nandan Bahuguna Garhwal University, Srinagar, Uttarakhand
11	Abdul Saboor Khan	Jamia Hamdard
12	B SELVASUNDARAM	SANKAR POLYTECHNIC COLLEGE
13	Dhruv Gandhi	Facile Maven Pvt Ltd
14	Ishita Prakash	Udai Pratap Autonomous College, Varanasi
15	Pushpanjali	Deen Dayal Upadhyaya Gorakhpur University, Gorakhpur
16	Sudhir Patil	IA
17	Santosh Ghadi	CRC in Geography, Govt. College Khandola Marcela Goa
18	Nida	Jamia millia islamia
19	NAVEEN CHAUHAN	Student
20	Dr D.Sasikala Devi	Sri Ramakrishna College of Arts & Science
21	TIMOTHY ROUBEN ANTHONY	ST. XAVIER'S COLLEGE, KOLKATA & PONDICHERRY UNIVERSITY (TWINNING)
22	Abdul Rohid	Rampurhat College, Geography Department
23	Afreena Bano	Department of Zoology, University of Kashmir
24	Prof.(Dr.)Sankar Narayan Sinha	University of Kalyani
25	MALLEPALLI. BHASKAR	HEARTFULNESS RESEARCH CENTRE, SMSF, UNIVERSITY OF MYSORE
26	DR RVS KRISHNA KUMAR	NARAYANA DENTAL COLLEGE & HOSPITAL
27	SUMATHI E	KUMARAGURU COLLEGE OF TECHNOLOGY
28	Shankhadeep Mahato	University of North Bengal
29	Narinder Kumar	Department of Sociology and Social Anthropology, Punjabi University, Patiala
30	Dona Roy	University of North Bengal

31	Anisha Chaurasia	NIMS University, Rajasthan
32	Mahavir Singh	Punjabi University Patiala
33	Dr SIDDIQUI LUBNA JAVED HASAN	Institute of Management & Research, MGM UNIVERSITY
34	ITD. PD. ER. SATYENDRA PRASAD RAJGOND	GONDWANA RATN SWARGI SHREE DUKHAN GOND GOTUL INTERNATIONAL TECHNOLOGY & RESEARCH CENTRE PACHFENWA (INDIA)
35	Dr. Jabeela Shirlin	SRM Institute of Science and Technology
36	anisha ganguly	Wildlife Institute of India
37	Pooja chitti	Kle society's SVS Bellubbi Arts and Commerce college Saundatti
38	Bhagyashri J Poleshi	Kle society's SVS Bellubbi Arta and Commerce College Saundatti.
39	Dr. Kaushalkumar Hareshbhai Desai	ITM Vocational University, Vadodara
40	Dr. Padmanabh Uddhav Veer	Bharati Vidyapeeth (Deemed To Be University) College of Engineering, Pune
41	S.SAHEETHA BANU	Jamal Mohamed college Trichy-20
42	Kalai Selva Nalla Kumari	Joy university
43	Mohanapriya TD	Chettinad Academy of Research and Education
44	Lalit Gautam	University of Lucknow
45	Dharmendra Kumar	Department of geography and disaster management, University of Kashmir
46	Praveena P L	Sethu Institute of Technology
47	aandog981@gmail.com	MA., BED
48	Charu Pawar	Dr.Ambekar Institute of Technology for Divyangjan, kanpur
49	SUJITHA K A	NESAMONY MEMORIAL CHRISTIAN COLLEGE
50	Harjot Kaur	Punjabi University, Patiala
51	Evangelin Saral N	B S Abdur Rahman Crescent Institute of Science and Technology
52	Nidhi Goyal	Government. Commerce College Kota
53	Jyoti	Nims University jaipur Rajasthan
54	Er. DEEPAK TIWARI DSK	RAIPUR, CHHATTISGARH
55	Dr. Bhupesh Debbarma	Department of Philosophy, Tripura University (A Central University), Suryamaninagar, Tripura West - 799022, India
56	K.Shakila Banu	Jamal Mohamed College (Autonomous) Trichy 20.
57	S.PEERANI	JAMAL MOHAMED COLLEGE
58	V. PAVITHRA	Jamal Mohamed College
59	Mamta	Panjab university
60	Dr. Amit Kumar, Asst. Prof. (Geog.)	Dr. Bhim Rao Ambedkar Government College, Sri Ganganagar
61	Priyanka Gogoi	D.D.R. College, Chabua

62	Jeffilda Esther J	BS Abdur Rahman Crescent Institute of Science and Technology
63	Dr Annapurna Metta	Amity University Chhattisgarh
64	Komal Bansal	Dr Bhimrao Ambedkar Govt College Sriganganagar
65	Shivam yadav	Himalayan institute of technology and management Lucknow
66	Baiengskhem S Lyngdoh	North-Eastern Hill University
67	Dr. P.Annie Alexandra	A.M.K.Technological Polytechnic College
68	Sukhpreet Singh	GNA University
69	Apeksha Chaudhary	Banasthali Vidyapith
70	Dhivyaa.R	Sri GVG Visalakshi College for Women
71	VACHHANI SANKETKUMAR BABUBHAI	DEPARTMENT OF COMMERCE AND MANAGEMENT, BHAKTA KAVI NARSINH MEHTA UNIVERSITY-JUNAGADH.
72	Emidaka Iakai	Shangpung College
73	Thirshatha M	Annamalai university
74	Myvizhi. A	Sri G. V. G Visalakshi College for Women
75	Rathnamala K	Sri Gvg Visalakshi College for Women
76	R.shubhakarini	B.S.Abdur Rahman Crescent Institute Of Science And Technology
77	Archana Kumari	Patna University
78	R. SHAGIFTHA ANJUM	B.S Abdur Rahman Crescent Institute of Science and Technology
79	Dr.. A. Jemila Percy	SRM Institute of Science and Technology, Ramapuram Campus
80	Dr.R.S.Priyadharshini	SRM Institute of Science and Technology, Ramapuram
81	R.Subbulakshmy	SRM Institute of Science and Technology, Ramapuram
82	Dr A B Manju	The Apollo University
83	Rashmi Ranjan Mohapatra	Hindalco Industries Limited
84	Dr. Manvir Kaur	Lovely Professional University, Punjab
85	Kulveer Singh	Punjabi University Patiala
86	Sanjay Kumar Panchal	Jayoti Vidyapeeth Womens University Jaipur
87	Manisha kumari	Patna University

Photos of the event with caption

Inaugural address by Dr. S. Shantha kumar



Lecture by Dr. Ruby Makhija of Founder of Why Waste Wednesdays Foundation, New Delhi



Lecture by Dr. M. Dwarakanath, Chairman of State Environmental Impact Assessment Authority (SEIAA), Government of Pondicherry

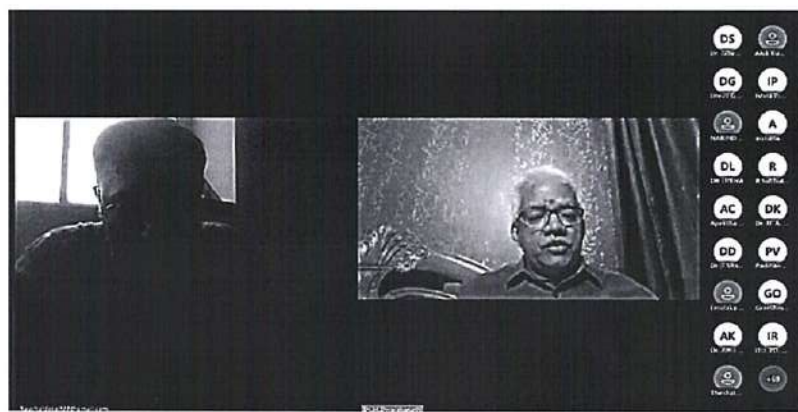



VIT

Vellore Institute of Technology
(Deemed to be University under section 3 of UGC Act, 1956)

Vellore- 632 014, Tamil Nadu

CENTRE FOR CLEAN ENVIRONMENT

Online Seminar
on

“Ending Plastic Pollution through Innovation, Policy, and Public Engagement”

11th June 2025



WORLD ENVIRONMENT DAY

BEAT PLASTIC POLLUTION

ABOUT VIT

Vellore Institute of Technology (VIT) was founded in 1984 as Vellore Engineering College by the Honourable Chancellor Dr. G. Viswanathan. The Institution has grown steadily since its humble beginning. VIT attracts students from all over India and more than 50 countries because of its excellence. VIT has emerged as one of India’s best Institutes and aspires to become a global leader in education. Quality in teaching-learning, research and innovation make VIT a unique place to learn. VIT is the 10th best University Category, 13th Best Research and the 11th best Engineering institution of India in 2024 NIRF Ranking published by the Ministry of Education, Govt. of India. VIT is ranked among the top 150 universities in Asia according to the QS Asia University Rankings 2025, and is placed in the 791–800 band in the QS World University Rankings 2025. VIT achieved NAAC Accreditation with A++ grade in the 4th cycle. VIT is one of the top 3 institutions of India and within the top 501-600 Universities of the world as Per Shanghai ARWU Ranking 2024. VIT is also Ranked by Times Higher Education (THE) World University Ranking, US News Ranking, Round University Ranking, Russia and others. VIT is the first institute of India to receive QS 4-Star rating in overall category and QS 5-Star rating in teaching, employability, facilities, innovation and inclusiveness.



ABOUT CENTRE FOR CLEAN ENVIRONMENT

Centre for Clean Environment (CCE) at Vellore Institute of Technology (VIT) was established and formally inaugurated on 30th April 2024 with the intention to associate with Global Sustainable Development Goals adopted by the United Nations. CCE focuses on finding innovative technologies and sustainable solutions for the environmental issues from local to global scale. The centre address environmental concerns by collaborating with government, industry, non-government organizations and leading academic partners through national and international research networks. Our thrust area of research and consultancy revolves around water & wastewater treatment & management, solid waste management, waste to wealth, emerging contaminants, novel methods for environmental remediation, multidisciplinary approach towards environmental monitoring, bioremediation of organic pollutants in soil and water, environmental systems design, computations & modelling, heavy metal removal, air pollution & climate change, environmental forensic analysis, health risks & environmental impact assessment, environmental awareness, clean energy and other relevant areas of environmental concerns.



ABOUT THE SEMINAR

World Environment Day is an annual global event held on June 5th since 1973, aiming to raise awareness and drive action for the protection of our environment. With participation from over 143 countries each year, World Environment Day serves as a significant platform for public outreach, uniting businesses, non-governmental organizations, communities, governments, and celebrities in advocating for environmental causes. The theme for World Environment Day 2025 is “Ending Plastic Pollution”, emphasizing the urgent need to tackle plastic pollution through innovation, policy reforms, and public engagement. Plastic pollution poses a significant threat to ecosystems, human health, and biodiversity. The United Nations Environment Programme (UNEP) is leading global efforts to cut plastic pollution by 80% by 2040 through a legally binding treaty and a shift to a circular economy.

In connection with World Environment Day celebrations, the Centre for Clean Environment at Vellore Institute of Technology, Vellore, is organizing an online seminar on ‘Ending Plastic Pollution through Innovation, Policy, and Public Engagement’. The primary objective of this seminar is to create awareness about the challenges of plastic pollution, its impact on ecosystems and human health, and to discuss innovative solutions, policies, and community engagement strategies to effectively reduce and eventually end plastic pollution. The seminar will feature lectures delivered by experts from premier academic institutions and industry.

SPEAKERS



Dr. Ruby Makhija
Founder, Why Waste
Wednesdays Foundation,
New Delhi



Dr. M. Dwarakanath
Chairman, SEIAA,
Government of Pondicherry,
Visiting Professor, PSGCAS
& PSGIM, Coimbatore, TN

ORGANIZING COMMITTEE

Convener

Dr. Shantha Kumar. S
Director
Centre for Clean Environment

Co-convener

Dr. B. Srimuruganandam
Professor
Centre for Clean Environment

Coordinators

Dr. Monali Priyadarshini
Assistant Professor
Centre for Clean Environment

Dr. Greeshma. O
Assistant Professor
Centre for Clean Environment

WHO CAN ATTEND

Participation is open to all professionals, researchers, academia, industries, and students.

REGISTRATION



Registration link

<https://forms.gle/UKngm71u5eD3XX88>



Last Date of Registration

10th June 2025

For further details contact:
vitccevents@gmail.com

MODE OF DELIVERING: ONLINE

The link will be sent to registered participants

Time: 10:00 am to 12:30 pm

E-Certificate will be provided for the registered participants who attend both the sessions.



EVENT REPORT
Industry-Alumni Guest Lecture

Resource Person : Mrs.Nitu Joseph, Declutter Solutions Pvt Ltd

Date : 12.3.2025

Venue : CDMM 104

Topic of Lecture : Circular economy for combating climate change- A multi-dimensional perspective from the waste management Industry

Number of participants: 53

Introduction:

On March 12, 2025, the students of the "Global Warming" course were privileged to attend a highly insightful guest lecture delivered by a distinguished alumna from the industry, focusing on the critical intersection of circular economy principles and climate change mitigation. The session aimed to provide students with a practical, industry-driven perspective on how sustainable waste management practices can significantly contribute to environmental conservation.

Overview:

The lecture commenced with a foundational understanding of the Circular Economy (CE), moving beyond the traditional "reduce, reuse, recycle" paradigm. The speaker meticulously explained CE as a systemic approach to economic development designed to benefit businesses, society, and the environment. Key principles emphasized were designing out waste and pollution by eliminating waste at the design stage of products and services; keeping products and materials in use by extending product lifecycles through repair, reuse, remanufacturing, and recycling; and regenerating natural systems through shifting towards renewable energy sources and regenerating natural capital.

The lecture then clearly established the direct link between a linear "take-make-dispose" economy and the escalating climate crisis. The speaker highlighted how CE models can combat climate change by reducing greenhouse gas emissions, minimizing virgin material consumption and enhancing carbon sequestration.

A significant portion of the talk was dedicated to exploring the multi-dimensional perspective of the circular economy from the waste management industry. The economic dimensions were discussed using the new business models, value creation from waste, job creation in green sectors, and the potential for reduced operational costs for industries adopting CE principles. Then, the environmental dimensions were elaborated with pollution prevention, resource efficiency, biodiversity protection, and overall ecosystem health. The social dimensions attempted covering aspects like community engagement, consumer awareness, equitable resource distribution, and improved public health outcomes from better waste management. The policy & regulatory frameworks were also discussed.

Practical insights from Declutter Solutions Pvt Ltd:

The speaker provided a fascinating glimpse into the real-world application of circular economy principles through the lens of Declutter Solutions Pvt Ltd. The session detailed their operational practices like advanced segregation & collection, material recovery facilities, value addition & upcycling initiatives, reverse logistics and industry partnerships and community engagement & awareness

Professional journey and experience:

The speaker shared their personal journey and experiences within the dynamic waste management industry, offering valuable career insights. They spoke about the initial challenges of establishing sustainable waste management models in a traditionally linear economy and the perseverance required to bring about change. The passion for transforming waste into wealth and contributing to environmental stewardship was palpable. They highlighted the interdisciplinary nature of their work, requiring a blend of engineering, business acumen, policy understanding, and strong communication skills to engage diverse stakeholders, from local communities to large corporations. This personal narrative profoundly resonated with the students, providing a tangible example of impact-driven careers.

Interactive session and student impact:

The session was notably interactive and highly engaging, transforming a lecture into a lively dialogue. Students actively participated, posing insightful questions regarding:

- ✓ The economic viability of various circular business models.
- ✓ Challenges in scaling up waste management solutions in India.
- ✓ Specific technologies used for waste processing and material recovery.
- ✓ Career opportunities within the circular economy sector.
- ✓ The role of individual actions in promoting circularity.

The speaker addressed each query with clarity and practical examples, drawing directly from her rich experience. The dynamic exchange fostered critical thinking and allowed students to connect theoretical concepts learned in the "Global Warming" course with real-world applications. Some of the session pictures are shared below.

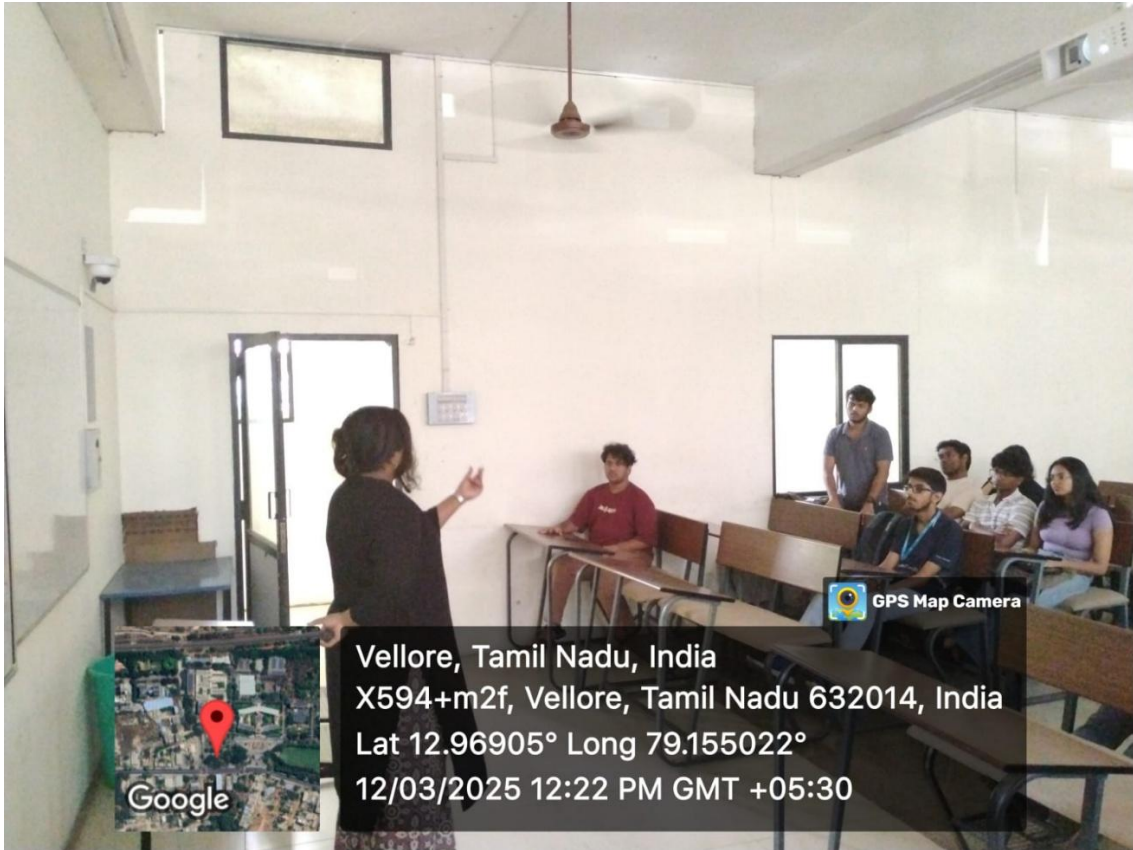



Conclusion:

The guest lecture provided an invaluable bridge between academic learning and industry practice. It offered a multi-faceted and pragmatic understanding of how the circular economy, spearheaded by innovative waste management solutions like those at Declutter Solutions Pvt Ltd, is not just an environmental imperative but also an economic opportunity in the fight against climate change. The interactive nature of the session ensured maximum learning and left a lasting, positive impact on all attending students.



VIT
Vellore Institute of Technology



SCHOOL OF CIVIL ENGINEERING

Department of Environmental and Water Resources Engineering

Cordially invites you for the

Alumni Industry Expert Lecture

on

“Circular economy for combating climate change- A multi-dimensional perspective from the waste management Industry”

by



Mrs. Nitu Joseph

Chief Technology Officer and Co-founder
Declutter Solutions Pvt Ltd, Coimbatore
Tamil Nadu, India.

Education:

M. Tech - Energy and Environmental Engineering, VIT, Vellore, 2017.
B.Tech - Civil Engineering, University of Calicut, 2015.

Expertise:

Nitu Joseph is having 8 years of industry experience, including roles at CSIR-NEERI and Chintan Environmental Research and Action Group. She is a former BIRAC SPARSH Social Innovation Fellow and currently, she is the Co-founder and CTO of Declutter Solutions Pvt Ltd. She has led the startup in securing prestigious grants such as TANSEED 5.0, BIRAC BIG, and winning the MSME Women Hackathon.

Date & Time: 12.03.2025 (Wednesday) at 11.00 a.m.

Venue: CDMM 104, VIT, Vellore

Dr. N. Vaani
Coordinator

Dr. S. Mahenthiran
HOD - EWRE
Dr. S. Mahenthiran, M.E., Ph.D.
Associate Professor & HOD
Department of Environmental & Water Resources Engineering
School of Civil Engineering
Vellore Institute of Technology (VIT)
Vellore - 620 014, Tamil Nadu, India

Dr. M. P. Subbalaakrishnan, Ph.D.
Professor - CSCE
School of Civil Engineering
Vellore Institute of Technology (VIT)
Vellore - 620 014, Tamil Nadu, India

Ś-175/2024

Lublin, 12 December 2024

Dr. Mahesh Ganesapillai
Professor - School of Chemical Engineering
Vellore Institute of Technology,
Vellore 632014, INDIA.

We are delighted to extend an invitation to you to cooperate as a Visiting Professor with the Faculty of Environmental Engineering of Lublin University of Technology in Lublin, Poland, in the upcoming semester of academic year 2024/2025. Your expertise in the field of Waste Management would be invaluable to our domestic university students as well as Erasmus international students.

The Proposed Course is as follows:

1. Energy of the Future (30 academic hours)
2. Waste to Energy (30 academic hours)

We believe that your participation in our academic program would significantly enrich the learning experience of our students and contribute to the advancement of knowledge in the field of sustainable energy.

Your cooperation is greatly appreciated.

Yours sincerely,

DZIEKAN
Wdziału Inżynierii Środowiska

prof. dr hab. inż. Beata Kowalska

Words of gratitude and student feedback > Inbox x



Justyna Gołębiowska

to me ▾

Tue 10 Jun, 14:49

Dear Professor,

On behalf of Prof. Beata Kowalska and myself, I would like to **thank you for your valuable cooperation** with the Faculty of Environmental Engineering and Energy.

We appreciate the effort you have put into this work and are grateful for the time you have dedicated to our students.

We would be delighted to continue our cooperation to the same extent in the upcoming academic year.

Additionally, here is the student evaluation you requested.

Best regards,

dr inż. **Justyna Gołębiowska**

Wydział Inżynierii Środowiska i Energetyki

+48 81 538 44 06





POLITECHNIKA
LUBELSKA



School of Advanced Sciences

VALUE ADDED / GUEST LECTURE / SEMINAR / WORKSHOP / SYMPOSIUM / CONFERENCE / TRAINING PROGRAM DETAILS

Event type	Gravitas 24		
Title of the event	1. Climate Change and energy options for a sustainable future by Prof. Dinesh Kumar Srivastava. 2. Panel Discussion on Building a Sustainable World: India's contribution to Global SDGs		
Date (From-To)	28.09.2024 (Saturday)		
Time	10:00 AM to 1:00 PM		
Venue	TT 513 (SAS, Smart Classroom)		
No. of Participants	25		
Coordinator(s)	Emp. ID.	Faculty Name	Department
	19574	Amit Roy	Physics, SAS
	13684	Samir Ranjan Meher	Physics, SAS
	18050	Dhanoj Gupta	Physics, SAS
Resource Person Name	Dr. D. K. Srivastava		
Designation	Honorary Visiting Professor (Homi Bhabha Chair Professor, National Institute of Advanced Studies, Bengaluru.)		
Organization Details	National Institute of Advanced Studies, Indian Institute of Science Campus, Bengaluru		
Place	Bengaluru, India		
E-mail	dinesh.srivastava@nias.res.in		
Mobile no.	9836176868		

18050

Signature of the Coordinator
(19574)
(13684)

Signature of the Dean / Director
Dean
School of Advanced Sciences
Vellore Institute of Technology
(Deemed to be University under section 3 of UGC Act, 1956)
Vellore - 632 014, Tamil Nadu, India



VIT[®]
Vellore Institute of Technology
(Deemed to be University under section 3 of UGC Act, 1956)

20th September 2024

Dr. Arunai Nambi Raj N
Dean, School of Advanced Sciences

To
Dr. Dinesh Kumar Srivastava
Honorary Visiting Professor
School of Natural Sciences and Engineering
National Institute of Advanced Studies
Indian Institute of Science Campus
Bengaluru - 560012, India

Dear Sir,

Sub: Invitation to serve as a resource person in a GraVITas 2024 event.

Greetings!

It's my pleasure to invite you as a resource person to deliver a lecture on "Climate change and energy options for a sustainable future" on 28th September 2024, following which a panel discussion on sustainable development goals of 6 & 7. This event is arranged by the department of physics, School of Advanced Sciences, as a part of GraVITas 2024—the Technical Carnival of the institute. Your expertise and experience will certainly add value to our event.

Event coordinator Dr. Amit Roy, mobile number: 8861540705 will coordinate with you.

Looking forward to meeting you in the event.

Thank you

With best regards,

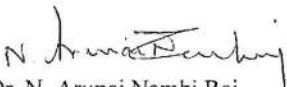
Dr. N. Arunai Nambi Raj
Dean, School of Advanced Sciences



Vellore - 632 014, Tamil Nadu, India; Phone: 91 - 416 - 2243091 (10 Lines) Fax: 91- 416 - 2243092

E-mail: registrar@vit.ac.in

www.vit.ac.in

VIT - A place to learn. A chance to grow

Brochure / Circular of the Event / Programme Schedule

Panel Discussion









ON

Building a Sustainable World: India's Contributions to Global SDGs

Organized by

Department of Physics
School of Advanced Sciences, VIT Vellore,



<p>Dr. Dinesh Kumar Srivastava Honorary Visiting Professor National Institute of Advanced Studies Indian Institute of Science Bangaluru, India.</p>		<p>Dr. K. Palanisamy Professor Department of Energy and Power Electronics School of Electrical Engineering VIT, Vellore, India.</p>	
<p>Dr. R. Vijayaraghavan Professor Department of Chemistry School of Advanced Sciences VIT, Vellore, India.</p>		<p>Dr. K. Padmanabhan Professor Department of Manufacturing Engineering School of Mechanical Engineering VIT, Vellore, India.</p>	
<p>Dr. N. R. Sathya Swaroop Professor Department of Physics School of Advanced Sciences VIT, Vellore, India.</p>		<p>Dr. A. Senthil Kumar Professor Department of Chemistry CO2 Research & Green Technologies Centre VIT, Vellore, India.</p>	
<p>Dr. Abhinav Anand Assistant Professor Department of Physics School of Advanced Sciences VIT, Vellore, India.</p>		<p>Dr. Arunkumar Palaniappan Assistant Professor Centre for Biomaterials, Cellular and Molecular Theranostics VIT, Vellore, India.</p>	

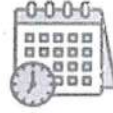

28th September 2024
10.00 A.M. — 1.00 PM
Venue: Technology Tower

Contact:

Dr. Amit Roy, Email: amit.roy@vit.ac.in, Phone: +91-8861540705

Dr. Samir Ranjan Meher, Email: samirmeher@vit.ac.in, Phone: +91-9940150337

Dr. Dhanoj Gupta, Email: dhanoj.gupta@vit.ac.in, Phone: +91-8649861514



Head of the Department
Department of Physics
School of Advanced Sciences
Vellore Institute of Technology
(Deemed to be University under section 3 of UGC Act, 1956)
Vellore – 620 017, Tamil Nadu, India.



VIT
Vellore Institute of Technology
(Deemed to be university under section 3 of UGC ACT, 1956)

graVITas '24
UNLEASH YOUR GENIUS

27-29, September 2024

Physics Department, School of Advanced Sciences

VIT Vellore

Under the banner of Gravitas 24

organizes a lecture on

**Climate change and energy options for a
sustainable future**

Speaker: Prof. Dinesh Kumar Srivastava

Schedule: 10:00 am; September 28, 2024 (Saturday)

Venue: Technology Tower



Event QR Code

About the Speaker:

Prof. Dinesh Kumar Srivastava is Homi Bhabha Chair Professor in the Energy and Environment Programme at NIAS, IISc campus Bengaluru. Prof. Srivastava has held many distinguished positions, such as DAE Raja Ramanna Fellow; Director and Distinguished Scientist in Variable Energy Cyclotron Centre, Kolkata; Emeritus Professor, Homi Bhabha National Institute. Prof. Srivastava is a Fellow of the National Academy of Sciences and the Indian National Science Academy.

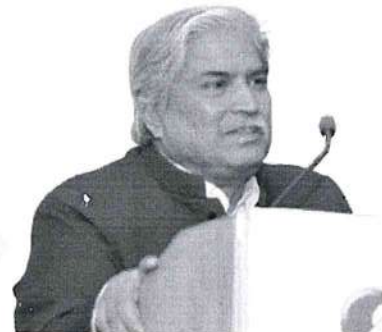

@evitgravitas

@Gravitas.VITvellore

groVITas VIT

@GraVITas_VIT

@vellore_vit

@vituniversity

Vellore Institute of Technology

@VIT_univ

Head of the Department
Department of Physics
School of Advanced Sciences
Vellore Institute of Technology
(Deemed to be university under section 3 of UGC ACT, 1956)
Vellore - 632014, Tamil Nadu, India.

A REPORT ON

The event and talk were organized in offline mode on 28/09/2024 from 10:00 am -1:00 pm in TT 513 as a part of Gravitas 24. A lecture was delivered on “Climate Change and energy options for a sustainable future” from 10:00 AM -11: 00 AM, followed by a panel discussion on sustainable development goals of 6 &7 from 11:00-1:00 pm. The talk was attended by 25 participants and several audience at the gravitas 24 event. The talk was very interactive, and all participants enjoyed a very interactive panel session that took place from 11:00 am to 1:00 pm. Further the session extended for question and answer till 1:50 pm. The geotagged photos are attached as part of the report.

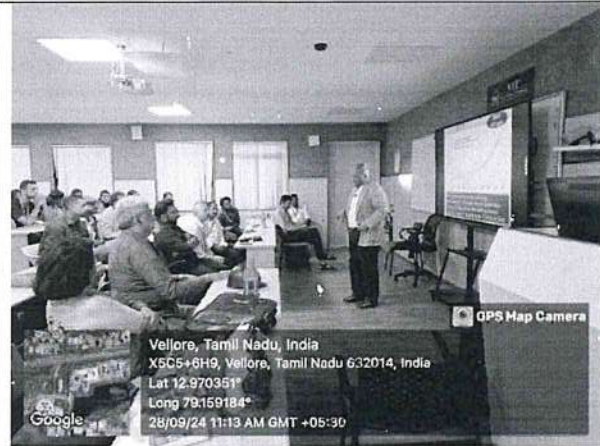

[Handwritten Signature]
18050

[Handwritten Signature] (19524)

Signatures of Coordinators

[Handwritten Signature] (13684)

Expenditure / Revenue Details of the Event

The lecture on “**Climate Change and energy options for a sustainable future followed by panel discussion on sustainable development goals of 6 &7** ” is being held for the benefit of Vellore Institute of Technology’s students and faculty. As a result, no registration fees were collected by department of Physics, SAS. Furthermore, no money was made during the talk by department of Physics, SAS. In addition, we claim Rs. 4000 as remuneration and Rs/ 500 for bookey for the resource person. As a result, the total expenditure for this event is Rs. 4500 (four thousand five hundred only). Nil revenue.

Allyssa
1050
Junit Roy (19574)
Signatures of Coordinators
113601

N. Anand Perumal
Signature of the Dean/Director
Dean
School of Advanced Sciences
Vellore Institute of Technology
(Deemed to be University under section 3 of UGC Act, 1956)
Vellore - 632 014, Tamil Nadu, India



VIT[®]
Vellore Institute of Technology
(Deemed to be University under section 3 of UGC Act, 1956)

SCHOOL OF ADVANCED SCIENCES
Department of Chemistry

We cordially invite you for the
Foreign Expert Special Lecture on

**Aerosols/Particulate Matter (PM):
Their Climate Contributions and Human Health Impacts
of Interest to India.**

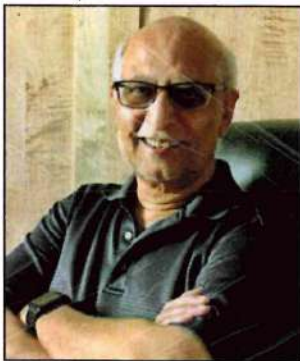

Prof. A. R. Ravishankara
University Distinguished Professor
Departments of Chemistry and Atmospheric Science,
Colorado State University, Fort Collins, CO USA

Date: 6th November 2024 (Wednesday)

Time: 3:00 PM

Venue: Kamraj Auditorium, TT712

Faculty Coordinators/Chemistry (SAS):

Dr. Mausumi Goswami

Dr. R. Vijayaraghavan

Dr. G. Thirumanavelan

Dr. S. Sarveswari
HOD, Chemistry

Dr. N. Arunai Nambi Raj
Dean, SAS

Dean
School of Advanced Sciences
Vellore Institute of Technology
(Deemed to be University under section 3 of UGC Act, 1956)
Vellore - 632 014, Tamil Nadu, India

VIT - A Place to learn; A Chance to grow

Foreign Expert Special Lecture



School of Advanced Sciences
Department of Chemistry
Vellore Institute of Technology

Aerosols/Particulate Matter (PM): Their climate contributions and human health impacts of interest to India.



Prof. A.R. Ravishankara

University Distinguished Professor, Departments of Chemistry and Atmospheric Science, Colorado State University, Fort Collins, CO, USA

Prof. Ravishankara is a University Distinguished Professor in the Departments of Chemistry and Atmospheric Science at the Colorado State University, Fort Collins, USA. He has worked on the chemistry of the Earth's atmosphere related to stratospheric ozone depletion, climate change, and air quality. His studies have significantly contributed to understanding ozone layer depletion, the role of chemically active species on climate, and urban air pollution. He has close to 400 publications with an h-index of 101. He is a member of the US National Academy of Sciences, a Foreign Member of the Royal Society (London), and a Foreign Fellow of the Indian National Science Academy. He currently serves on the scientific advisory panel of the Climate and Clean Air Coalition (CCAC) of United Nations

Environment Programme (UNEP) and the Steering Committee for the UNEP program to monitor Ozone Depleting Substances. He is the recipient of several distinguished awards including the Polanyi Medal of the Royal Society of Britain, the Stratospheric Ozone Protection award of the US Environmental Protection Agency, and the American Chemical Society's award for Creative Advances in Environmental Sciences.

ABSTRACT :

I will very briefly describe how aerosols have led to lower contributions of India to global climate change and the health impacts of the aerosols over India. I will briefly describe how we obtain surface PM_{2.5} (particulate matter of diameter less than 2.5 micrometers) from satellite data. Then, I will describe the health impacts of PM_{2.5} as measured by premature mortality. I will highlight the contributions of PM in non-urban India. Lastly, I will provide rough estimates of the measures needed to meet national ambient air quality standards in India from the changes observed during the COVID-19 shutdowns and lockdowns.

Date: 6th November, 2024 (Wednesday)

Time: 3.00 PM

Venue: Kamraj Auditorium, TT 712





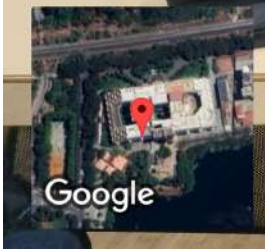
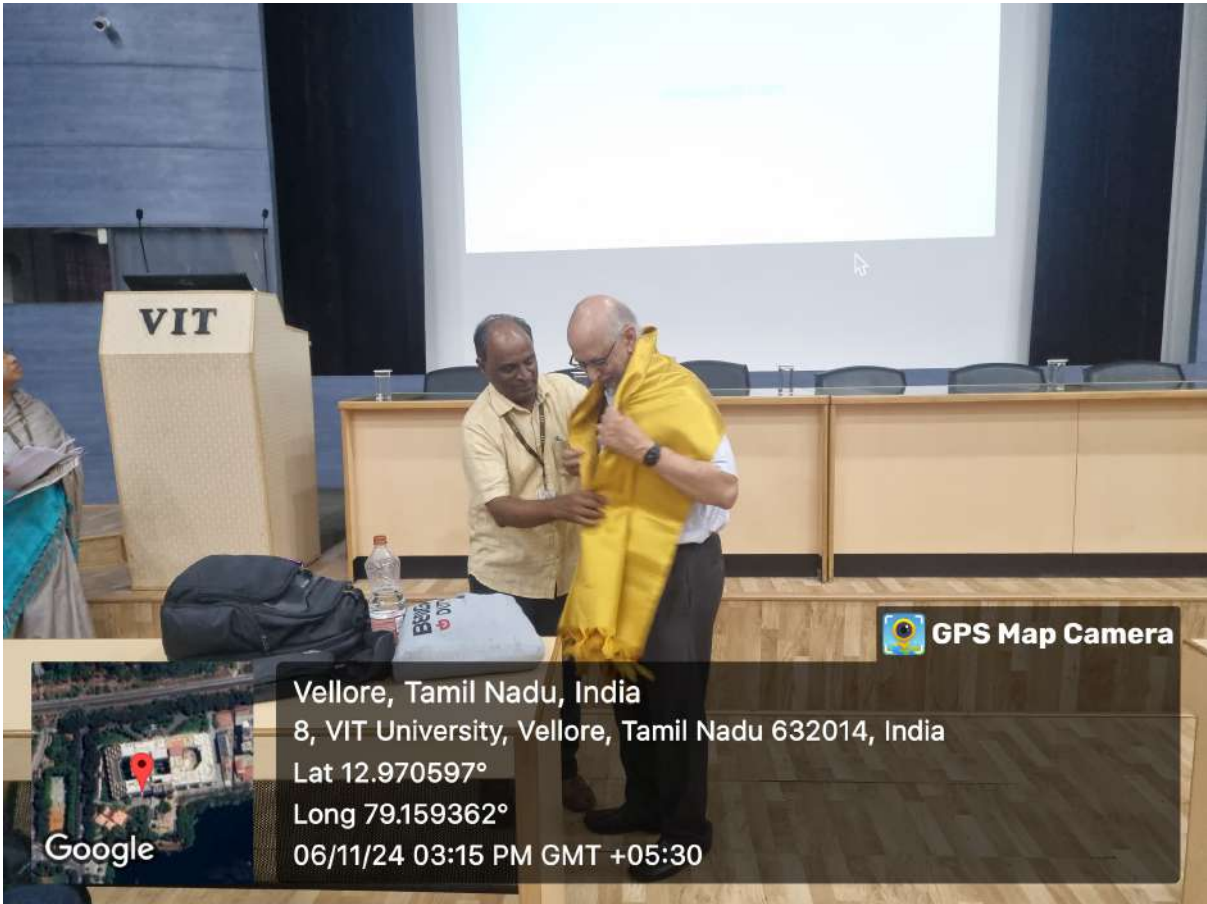

Vellore, Tamil Nadu, India
8, VIT University, Vellore, Tamil Nadu 632014, India
Lat 12.970597°
Long 79.159362°
06/11/24 03:15 PM GMT +05:30

GPS Map Camera

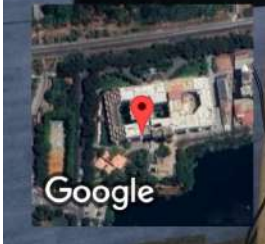
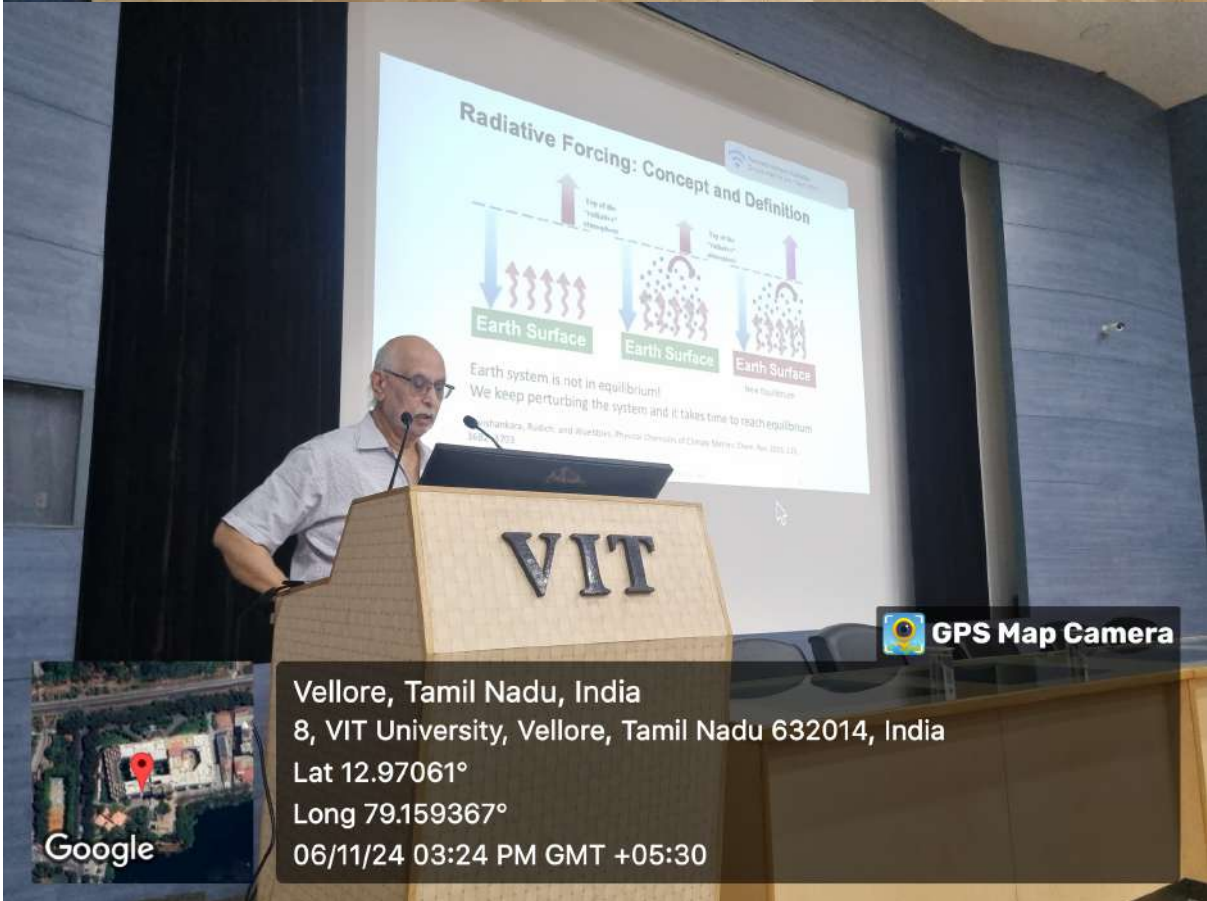

Vellore, Tamil Nadu, India
8, VIT University, Vellore, Tamil Nadu 632014, India
Lat 12.97061°
Long 79.159367°
06/11/24 03:24 PM GMT +05:30

GPS Map Camera



GPS Map Camera

Vellore, Tamil Nadu, India
 8, VIT University, Vellore, Tamil Nadu 632014, India
 Lat 12.97061°
 Long 79.159367°
 06/11/24 03:24 PM GMT +05:30

Google

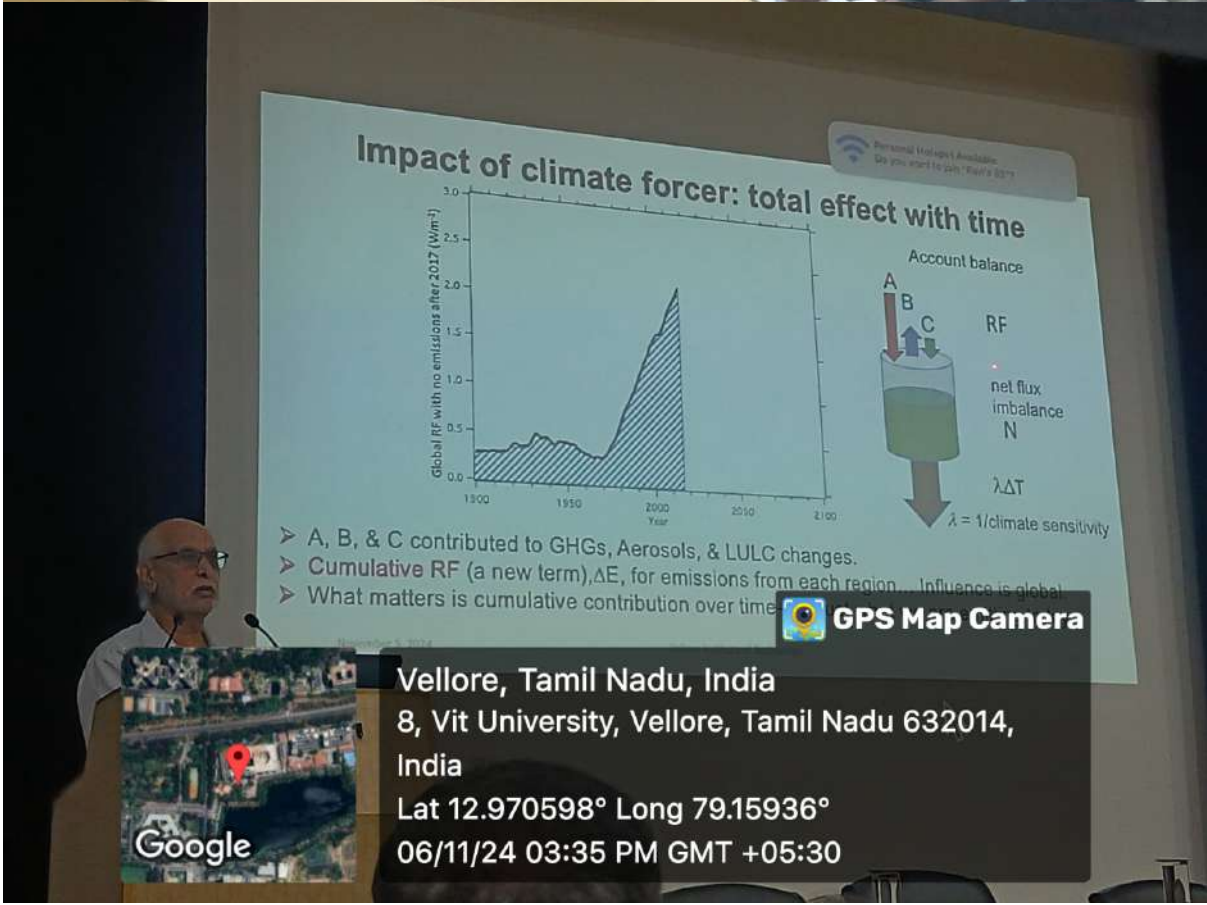

Personal Hotspots Available
 Do you want to join? Tap to join

Impact of climate forcer: total effect with time

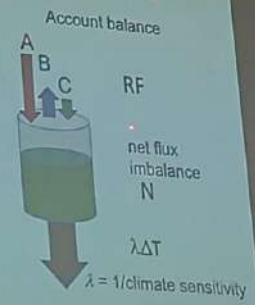
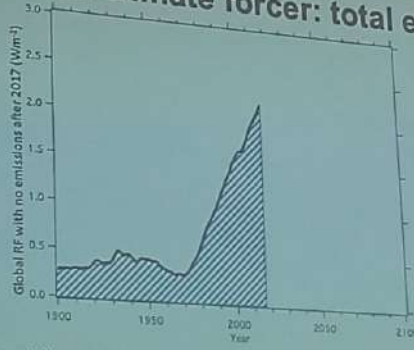

- > A, B, & C contributed to GHGs, Aerosols, & LULC changes.
- > Cumulative RF (a new term), ΔE, for emissions from each region... Influence is global
- > What matters is cumulative contribution over time

GPS Map Camera

Vellore, Tamil Nadu, India
 8, Vit University, Vellore, Tamil Nadu 632014,
 India
 Lat 12.970598° Long 79.15936°
 06/11/24 03:35 PM GMT +05:30

Google



 GPS Map Camera



Vellore, Tamil Nadu, India
8, VIT University, Vellore, Tamil Nadu 632014, India
Lat 12.970597°
Long 79.159362°
06/11/24 03:15 PM GMT +05:30

International Relations

Details of Visitors

Prof. A. R. Ravishankara
University Distinguished Professor
Colorado State University, USA

Dr. Elangannan Arunan, Professor, Department of Inorganic and Physical Chemistry
Indian Institute of Science Bangalore

DATE: 06th November 2024, Wednesday

Schedule:

9.00 AM	Arrival in Vellore Campus (Guest House)
10.30 AM to 11.00 AM	Meeting with IR Officials (IR Office)
11.00 AM- 11.15 AM	Meeting with Vice-President
11.25AM – 11.40 PM	Meeting with Vice-Chancellor
11.45 AM- 12.00 PM	Meeting with Pro Vice-Chancellor
12.00 PM- 1.00 PM	Visit to CO ₂ Research Center
1.00 PM – 2.00 PM	Lunch
2.00 PM- 2.30 PM	Visit to Centre for Clean Environment
3.00 PM- 5.00PM	Seminar in Kamaraj Auditorium
6.00 PM	Departure to Bangalore



Mausumi Goswami <mausumi.goswami@vit.ac.in>

PAYMENT REFERENCE - REG.,

1 message

Jayanthimala M <jayanthimala.m@vit.ac.in>
To: mausumi.goswami@vit.ac.in

Fri, Apr 4, 2025 at 1:01 PM

Dear Sir / Madam

We have processed the Payment as per your request. The transaction reference number is given below:

Claim Number	:	46204[1]16363
Name of the bank holder	:	E Arunan
Bank Name	:	STATE BANK OF INDIA
Account Number	:	10270643528
IFSC Code	:	SBIN0002215
Amount	:	4991/-
UTR Number	:	IDIBN52025032753855381
Payment Date	:	27.03.2025

NOTE:

Our Payment process is through Indian Bank, So UTR / Ref No. will not be generated (Internal Transfer).

If the amount is not credited to the beneficiary account kindly contact through the Email.

Thanks & Regards,

Jayanthimala. M*Senior Accountant**Finance Department,**VIT-Vellore-14.***Disclaimer:***This message was sent from Vellore Institute of Technology. The contents of this email may contain legally protected*

confidential or privileged information of "Vellore Institute of Technology". If you are not the intended recipient, you should not disseminate, distribute or copy this e-mail. Please notify the sender immediately and destroy all copies of this message and any attachments. If you have received this email in error, please promptly notify the sender by reply email and delete the original email and any backup copies without reading them.

Prof. A.R. Ravishankara's visit to VIT, Vellore

7 messages

Dr. Sainu Franco, International Relations Officer <ir10@vit.ac.in>

Tue, Oct 29, 2024 at 12:49 AM

To: Director Centre for Clean Environment <director.cce@vit.ac.in>

Cc: Tamas Kumar Panda <tamaskumpanda@vit.ac.in>, Mausumi Goswami <mausumi.goswami@vit.ac.in>, "Dr.R.Seenivasan Director (IR)" <director.ir@vit.ac.in>, Dr JNV Raghuram Asst Director- IR <ir3@vit.ac.in>, International Relations <international@vit.ac.in>

Dear Sir,

Prof. A. R. Ravishankara a member of the US National Academy of Science and a foreign member of the Royal Society (London) , is visiting VIT **on the 6th of November**. He currently chairs the Board on Atmospheric Science and Climate of the NAS and serves on the scientific advisory panel of the Climate Clean Air Coalition. He is also a recipient of several distinguished awards which include the Polanyi Medal of the Royal Society, The Stratospheric Ozone Protection award of the US Environmental Protection Agency, and the American Chemical Society's award for Creative Advances in Environmental Sciences. He has close to 400 publications and an h index of 101 (**CV is attached herewith**).

Wikipedia has some information on him: https://en.wikipedia.org/wiki/Akkihebbal_RavishankaraHis Google Scholar page: <https://scholar.google.com/citations?user=Gb0ClrsAAAAJ&hl=en><https://www.infosysprize.org/jury/2019/ravishankara.html>

In line with the visit, a seminar is being arranged on the 6th of November in Kamaraj Auditorium from the School of Advanced Sciences. Given his immense contribution to Climate Science and association with the United Nations Montreal protocol, an interaction session with him would be beneficial to CCE. I kindly request you to arrange an interaction with the faculty and researchers from CCE if possible.

DR. ELANGANNAN ARUNAN, Professor, Department of Inorganic and Physical Chemistry

Indian Institute of Science Indian Institute of Science Bangalore is also accompanying him. Please find attached both their CV's.

Kindly let me know your thoughts on this.

Warm regards,

Dr. Sainu Franco (Ms.)

International Relations Officer

O/o International Relations

Vellore Institute of Technology (VIT)

t: +91 416 2202074 / 2243118

Vellore - 632014 | Tamil Nadu, INDIA

e: ir10@vit.ac.ine: outboundexchange@vit.ac.ine: sainu.franco@vit.ac.inwww.vit.ac.in

Vellore Institute of Technology (VIT), India

Disclaimer:

This message was sent from Vellore Institute of Technology. The contents of this email may contain legally protected confidential or privileged information of "Vellore Institute of Technology". If you are not the intended recipient, you should not disseminate, distribute or copy this e-mail. Please notify the sender immediately and destroy all copies of this message and any attachments. If you have received this email in error, please promptly notify the sender by reply email and delete the original email and any backup copies without reading them.

2 attachments**Ravishankara-CV_9Jan2024_Long.doc**

217K

**arunan_cv_Sep2024.pdf**

390K

Mausumi Goswami <mausumi.goswami@vit.ac.in>

Mon, Oct 28, 2024 at 12:56 PM

To: Thirumanavelan G <velan.g@vit.ac.in>, Vijayaraghavan R <rvijayaraghavan@vit.ac.in>

IR office sent this email to CCE!

----- Forwarded message -----

From: **Dr. Sainu Franco, International Relations Officer** <ir10@vit.ac.in>

Date: Mon, Oct 28, 2024 at 12:22 PM

Subject: Prof. A.R. Ravishankara's visit to VIT, Vellore

To: Director Centre for Clean Environment <director.cce@vit.ac.in>

Cc: Tamas Kumar Panda <tamaskumpanda@vit.ac.in>, Mausumi Goswami <mausumi.goswami@vit.ac.in>, Dr.R.Seenivasan Director (IR) <director.ir@vit.ac.in>, Dr JNV Raghuram Asst Director- IR <ir3@vit.ac.in>, International Relations <international@vit.ac.in>

Dear Sir,

Prof. A. R. Ravishankara a member of the US National Academy of Science and a foreign member of the Royal Society (London) , is visiting VIT **on the 6th of November**. He currently chairs the Board on Atmospheric Science and Climate of the NAS and serves on the scientific advisory panel of the Climate Clean Air Coalition. He is also a recipient of several distinguished awards which include the Polanyi Medal of the Royal Society, The Stratospheric Ozone Protection award of the US Environmental Protection Agency, and the American Chemical Society's award for Creative Advances in Environmental Sciences. He has close to 400 publications and an h index of 101 (**CV is attached herewith**).

Wikipedia has some information on him: https://en.wikipedia.org/wiki/Akkihebbal_Ravishankara

His Google Scholar page: <https://scholar.google.com/citations?user=Gb0ClrsAAAAJ&hl=en>

<https://www.infosysprize.org/jury/2019/ravishankara.html>

In line with the visit, a seminar is being arranged on the 6th of November in Kamaraj Auditorium from the School of Advanced Sciences. Given his immense contribution to Climate Science and association with the United Nations Montreal protocol, an interaction session with him would be beneficial to CCE. I kindly request you to arrange an interaction with the faculty and researchers from CCE if possible.

DR. ELANGANNAN ARUNAN, Professor, Department of Inorganic and Physical Chemistry Indian Institute of Science Bangalore is also accompanying him. Please find attached both their CV's.

Kindly let me know your thoughts on this.

Warm regards,

Dr. Sainu Franco (Ms.)

International Relations Officer

O/o International Relations

Vellore Institute of Technology (VIT)

t: +91 416 2202074 / 2243118

e: ir10@vit.ac.in

e: outboundexchange@vit.ac.in

e: sainu.franco@vit.ac.in

Vellore - 632014 | Tamil Nadu, INDIA

www.vit.ac.in

Vellore Institute of Technology (VIT), India

Disclaimer:

This message was sent from Vellore Institute of Technology. The contents of this email may contain legally protected confidential or privileged information of "Vellore Institute of Technology". If you are not the intended recipient, you should not disseminate, distribute or copy this e-mail. Please notify the sender immediately and destroy all copies of this message and any attachments. If you have received this email in error, please promptly notify the sender by reply email and delete the original email and any backup copies without reading them.

--

Dr. Mausumi Goswami

Department of Chemistry

School of Advanced Sciences

Vellore Institute of Technology, vellore, India

Homepage: <https://mausumig.wixsite.com/research-page-mg>

Google Scholar Profile: <https://scholar.google.com/citations?user=jNvHLYwAAAAJ&hl=en>

"Being Challenged in Life is Inevitable, being defeated is optional"

2 attachments

 **Ravishankara-CV_9Jan2024_Long.doc**
217K

 **arunan_cv_Sep2024.pdf**
390K

Thirumanavelan G <velan.g@vit.ac.in>
To: Mausumi Goswami <mausumi.goswami@vit.ac.in>

Mon, Oct 28, 2024 at 12:58 PM

Good one. Hoping to materialize.

Regards,
Thirumanavelan

On Mon, Oct 28, 2024 at 12:56 PM Mausumi Goswami <mausumi.goswami@vit.ac.in> wrote:

IR office sent this email to CCE!

----- Forwarded message -----

From: **Dr. Sainu Franco, International Relations Officer** <ir10@vit.ac.in>

Date: Mon, Oct 28, 2024 at 12:22 PM

Subject: Prof. A.R. Ravishankara's visit to VIT, Vellore

To: Director Centre for Clean Environment <director.cce@vit.ac.in>

Cc: Tamas Kumar Panda <tamaskumpanda@vit.ac.in>, Mausumi Goswami <mausumi.goswami@vit.ac.in>, Dr.R.Seenivasan Director (IR) <director.ir@vit.ac.in>, Dr JNV Raghuram Asst Director- IR <ir3@vit.ac.in>, International Relations <international@vit.ac.in>

Dear Sir,

Prof. A. R. Ravishankara a member of the US National Academy of Science and a foreign member of the Royal Society (London) , is visiting VIT **on the 6th of November**. He currently chairs the Board on Atmospheric Science and Climate of the NAS and serves on the scientific advisory panel of the Climate Clean Air Coalition. He is also a recipient of several distinguished awards which include the Polanyi Medal of the Royal Society, The Stratospheric Ozone Protection award of the US Environmental Protection Agency, and the American Chemical Society's award for Creative Advances in Environmental Sciences. He has close to 400 publications and an h index of 101 (**CV is attached herewith**).

Wikipedia has some information on him: https://en.wikipedia.org/wiki/Akkihebbal_Ravishankara

His Google Scholar page: <https://scholar.google.com/citations?user=Gb0ClrsAAAAJ&hl=en>

<https://www.infosysprize.org/jury/2019/ravishankara.html>

In line with the visit, a seminar is being arranged on the 6th of November in Kamaraj Auditorium from the School of Advanced Sciences. Given his immense contribution to Climate Science and association with the United Nations Montreal protocol, an interaction session with him would be beneficial to CCE. I kindly request you to arrange an interaction with the faculty and researchers from CCE if possible.

DR. ELANGANNAN ARUNAN, Professor, Department of Inorganic and Physical Chemistry Indian Institute of Science Bangalore is also accompanying him. Please find attached both their CV's.

Kindly let me know your thoughts on this.

Warm regards,

Dr. Sainu Franco (Ms.)

International Relations Officer

O/o International Relations

Vellore Institute of Technology (VIT)

t: +91 416 2202074 / 2243118

e: ir10@vit.ac.in

e: outboundexchange@vit.ac.in

e: sainu.franco@vit.ac.in

Vellore - 632014 | Tamil Nadu, INDIA

www.vit.ac.in

Vellore Institute of Technology (VIT), India

Disclaimer:

This message was sent from Vellore Institute of Technology. The contents of this email may contain legally protected confidential or privileged information of "Vellore Institute of Technology". If you are not the intended recipient, you should not disseminate, distribute or copy this e-mail. Please notify the sender immediately and destroy all copies of this message and any attachments. If you have received this email in error, please promptly notify the sender by reply email and delete the original email and any backup copies without reading them.

--

Dr. Mausumi Goswami

Department of Chemistry

School of Advanced Sciences

Vellore Institute of Technology, vellore, India

Homepage: <https://mausumig.wixsite.com/research-page-mg>

Google Scholar Profile: <https://scholar.google.com/citations?user=jNvHLYwAAAAJ&hl=en>

"Being Challenged in Life is Inevitable, being defeated is optional"

Disclaimer:

This message was sent from Vellore Institute of Technology. The contents of this email may contain legally protected confidential or privileged information of "Vellore Institute of Technology". If you are not the intended recipient, you should not disseminate, distribute or copy this e-mail. Please notify the sender immediately and destroy all copies of this message and any attachments. If you have received this email in error, please promptly notify the sender by reply email and delete the original email and any backup copies without reading them.

Disclaimer:

This message was sent from Vellore Institute of Technology. The contents of this email may contain legally protected confidential or privileged information of "Vellore Institute of Technology". If you are not the intended recipient, you should not disseminate, distribute or copy this e-mail. Please notify the sender immediately and destroy all copies of this message and any attachments. If you have received this email in error, please promptly notify the sender by reply email and delete the original email and any backup copies without reading them.

Director Centre for Clean Environment <director.cce@vit.ac.in>

Tue, Oct 29, 2024 at 3:07 PM

To: "Dr. Sainu Franco, International Relations Officer" <ir10@vit.ac.in>

Cc: Tamas Kumar Panda <tamaskumpanda@vit.ac.in>, Mausumi Goswami <mausumi.goswami@vit.ac.in>, "Dr.R.Seenivasan Director (IR)" <director.ir@vit.ac.in>, Dr JNV Raghuram Asst Director- IR <ir3@vit.ac.in>, International Relations <international@vit.ac.in>

Dear Madam,

Thank you for your email and information.

We are happy to meet and interact with Dr. Ravishankara and Dr. Elangannan on 06th November 2024.

Kindly let me know the schedule of their visit to our centre so that I will inform our team accordingly.

Best Regards,

Prof. S. Shantha Kumar

Director, CCE

On Mon, Oct 28, 2024 at 12:22 PM Dr. Sainu Franco, International Relations Officer <ir10@vit.ac.in> wrote:

Dear Sir,

Prof. A. R. Ravishankara a member of the US National Academy of Science and a foreign member of the Royal Society (London), is visiting VIT **on the 6th of November**. He currently chairs the Board on Atmospheric Science and Climate of the NAS and serves on the scientific advisory panel of the Climate Clean Air Coalition. He is also a recipient of several distinguished awards which include the Polanyi Medal of the Royal Society, The Stratospheric Ozone Protection award of the US Environmental Protection Agency, and the American Chemical Society's award for Creative Advances in Environmental Sciences. He has close to 400 publications and an h index of 101 (**CV is attached herewith**).

Wikipedia has some information on him: https://en.wikipedia.org/wiki/Akkihebbal_Ravishankara

His Google Scholar page: <https://scholar.google.com/citations?user=Gb0ClrsAAAAJ&hl=en>

<https://www.infosysprize.org/jury/2019/ravishankara.html>

In line with the visit, a seminar is being arranged on the 6th of November in Kamaraj Auditorium from the School of Advanced Sciences. Given his immense contribution to Climate Science and association with the United Nations Montreal protocol, an interaction session with him would be beneficial to CCE. I kindly request you to arrange an interaction with the faculty and researchers from CCE if possible.

DR. ELANGANNAN ARUNAN, Professor, Department of Inorganic and Physical Chemistry

Indian Institute of Science Indian Institute of Science Bangalore is also accompanying him. Please find attached both their CV's.

Kindly let me know your thoughts on this.

Warm regards,

Dr. Sainu Franco (Ms.)

International Relations Officer

O/o International Relations

Vellore Institute of Technology (VIT)

t: +91 416 2202074 / 2243118

Vellore - 632014 | Tamil Nadu, INDIA

e: ir10@vit.ac.in

e: outboundexchange@vit.ac.in

e: sainu.franco@vit.ac.in

www.vit.ac.in

Vellore Institute of Technology (VIT), India

Disclaimer:

This message was sent from Vellore Institute of Technology. The contents of this email may contain legally protected confidential or privileged information of "Vellore Institute of Technology". If you are not the intended recipient, you should not disseminate, distribute or copy this e-mail. Please notify the sender immediately and destroy all copies of this message and any attachments. If you have received this email in error, please promptly notify the sender by reply email and delete the original email and any backup copies without reading them.

Disclaimer:

This message was sent from Vellore Institute of Technology. The contents of this email may contain legally protected confidential or privileged information of "Vellore Institute of Technology". If you are not the intended recipient, you should not disseminate, distribute or copy this e-mail. Please notify the sender immediately and destroy all copies of this message and any attachments. If you have received this email in error, please promptly notify the sender by reply email and delete the original email and any backup copies without reading them.

Mausumi Goswami <mausumi.goswami@vit.ac.in>

Tue, Oct 29, 2024 at 4:37 PM

To: Thirumanavelan G <velan.g@vit.ac.in>, Vijayaraghavan R <rvijayaraghavan@vit.ac.in>

FYIP

----- Forwarded message -----

From: **Director Centre for Clean Environment** <director.cce@vit.ac.in>

Date: Tue, Oct 29, 2024 at 3:08 PM

Subject: Re: Prof. A.R. Ravishankara's visit to VIT, Vellore

To: Dr. Sainu Franco, International Relations Officer <ir10@vit.ac.in>
Cc: Tamas Kumar Panda <tamaskumarpanda@vit.ac.in>, Mausumi Goswami <mausumi.goswami@vit.ac.in>, Dr.R.Seenivasan Director (IR) <director.ir@vit.ac.in>, Dr JNV Raghuram Asst Director- IR <ir3@vit.ac.in>, International Relations <international@vit.ac.in>

Dear Madam,

Thank you for your email and information.

We are happy to meet and interact with Dr. Ravishankara and Dr. Elangannan on 06th November 2024.

Kindly let me know the schedule of their visit to our centre so that I will inform our team accordingly.

Best Regards,
Prof. S. Shantha Kumar
Director, CCE

On Mon, Oct 28, 2024 at 12:22 PM Dr. Sainu Franco, International Relations Officer <ir10@vit.ac.in> wrote:

Dear Sir,

Prof. A. R. Ravishankara a member of the US National Academy of Science and a foreign member of the Royal Society (London) , is visiting VIT **on the 6th of November**. He currently chairs the Board on Atmospheric Science and Climate of the NAS and serves on the scientific advisory panel of the Climate Clean Air Coalition. He is also a recipient of several distinguished awards which include the Polanyi Medal of the Royal Society, The Stratospheric Ozone Protection award of the US Environmental Protection Agency, and the American Chemical Society's award for Creative Advances in Environmental Sciences. He has close to 400 publications and an h index of 101 (**CV is attached herewith**).

Wikipedia has some information on him: https://en.wikipedia.org/wiki/Akkihebbal_Ravishankara

His Google Scholar page: <https://scholar.google.com/citations?user=Gb0CirsAAAAJ&hl=en>

<https://www.infosysprize.org/jury/2019/ravishankara.html>

In line with the visit, a seminar is being arranged on the 6th of November in Kamaraj Auditorium from the School of Advanced Sciences. Given his immense contribution to Climate Science and association with the United Nations Montreal protocol, an interaction session with him would be beneficial to CCE. I kindly request you to arrange an interaction with the faculty and researchers from CCE if possible.

DR. ELANGANNAN ARUNAN, Professor, Department of Inorganic and Physical Chemistry Indian Institute of Science Indian Institute of Science Bangalore is also accompanying him. Please find attached both their CV's.

Kindly let me know your thoughts on this.

Warm regards,

Dr. Sainu Franco (Ms.)

International Relations Officer

O/o International Relations

Vellore Institute of Technology (VIT)

t: +91 416 2202074 / 2243118

e: ir10@vit.ac.in

e: outboundexchange@vit.ac.in

e: sainu.franco@vit.ac.in

Vellore - 632014 | Tamil Nadu, INDIA

www.vit.ac.in

Vellore Institute of Technology (VIT), India

Disclaimer:

This message was sent from Vellore Institute of Technology. The contents of this email may contain legally protected confidential or privileged information of "Vellore Institute of Technology". If you are not the intended recipient, you should not disseminate, distribute or copy this e-mail. Please notify the sender immediately and destroy all copies of this message and any attachments. If you have received this email in error, please promptly notify the sender by reply email and delete the original email and any backup copies without reading them.

Disclaimer:

This message was sent from Vellore Institute of Technology. The contents of this email may contain legally protected confidential or privileged information of "Vellore Institute of Technology". If you are not the intended recipient, you should not disseminate, distribute or copy this e-mail. Please notify the sender immediately and destroy all copies of this message and any attachments. If you have received this email in error, please promptly notify the sender by reply email and delete the original email and any backup copies without reading them.

--

Dr. Mausumi Goswami

Department of Chemistry

School of Advanced Sciences

Vellore Institute of Technology, vellore, India

Homepage: <https://mausumig.wixsite.com/research-page-mg>

Google Scholar Profile: <https://scholar.google.com/citations?user=jNvHLYwAAAAJ&hl=en>

"Being Challenged in Life is Inevitable, being defeated is optional"

Dr. Sainu Franco, International Relations Officer <ir10@vit.ac.in>

Tue, Nov 5, 2024 at 12:32 PM

To: Director Centre for Clean Environment <director.cce@vit.ac.in>

Cc: Tamas Kumar Panda <tamaskumpanda@vit.ac.in>, Mausumi Goswami <mausumi.goswami@vit.ac.in>, "Dr.R.Seenivasan Director (IR)" <director.ir@vit.ac.in>, Dr JNV Raghuram Asst Director- IR <ir3@vit.ac.in>, International Relations <international@vit.ac.in>

Dear Sir,

Please find attached the schedule for the visit of Dr. A R Ravishankara and team to VIT, tomorrow.

Thanks and regards,

Dr. Sainu Franco

International Relations Officer

O/o International Relations

Vellore Institute of Technology (VIT)

t: +91 416 2202074 / 2243118

Vellore - 632014 | Tamil Nadu, INDIA

e: ir10@vit.ac.in

e: outboundexchange@vit.ac.in

e: sainu.franco@vit.ac.in

www.vit.ac.in

Vellore Institute of Technology (VIT), India -

On Tue, Oct 29, 2024 at 3:08 PM Director Centre for Clean Environment <director.cce@vit.ac.in> wrote:

Dear Madam,

Thank you for your email and information.

We are happy to meet and interact with Dr. Ravishankara and Dr. Elangannan on 06th November 2024.

Kindly let me know the schedule of their visit to our centre so that I will inform our team accordingly.

Best Regards,

Prof. S. Shantha Kumar

Director, CCE

On Mon, Oct 28, 2024 at 12:22 PM Dr. Sainu Franco, International Relations Officer <ir10@vit.ac.in> wrote:

Dear Sir,

Prof. A. R. Ravishankara a member of the US National Academy of Science and a foreign member of the Royal Society (London) , is visiting VIT **on the 6th of November**. He currently chairs the Board on Atmospheric Science and Climate of the NAS and serves on the scientific advisory panel of the Climate Clean Air Coalition. He is also a recipient of several distinguished awards which include the Polanyi Medal of the Royal Society, The Stratospheric Ozone Protection award of the US Environmental Protection Agency, and the American Chemical Society's award for Creative Advances in Environmental Sciences. He has close to 400 publications and an h index of 101 (**CV is attached herewith**).

Wikipedia has some information on him: https://en.wikipedia.org/wiki/Akkihebbal_Ravishankara

His Google Scholar page: <https://scholar.google.com/citations?user=Gb0ClrsAAAAJ&hl=en>

<https://www.infosysprize.org/jury/2019/ravishankara.html>

In line with the visit, a seminar is being arranged on the 6th of November in Kamaraj Auditorium from the School of Advanced Sciences. Given his immense contribution to Climate Science and association with the United Nations Montreal protocol, an interaction session with him would be beneficial to CCE. I kindly request you to arrange an interaction with the faculty and researchers from CCE if possible.

DR. ELANGANNAN ARUNAN, Professor, Department of Inorganic and Physical Chemistry

Indian Institute of Science Indian Institute of Science Bangalore is also accompanying him. Please find attached both their CV's.

Kindly let me know your thoughts on this.

Warm regards,

Dr. Sainu Franco (Ms.)

International Relations Officer

O/o International Relations

Vellore Institute of Technology (VIT)

t: +91 416 2202074 / 2243118

Vellore - 632014 | Tamil Nadu, INDIA

e: ir10@vit.ac.in

e: outboundexchange@vit.ac.in

e: sainu.franco@vit.ac.in

www.vit.ac.in

Vellore Institute of Technology (VIT), India

Disclaimer:

This message was sent from Vellore Institute of Technology. The contents of this email may contain legally protected confidential or privileged information of "Vellore Institute of Technology". If you are not the intended recipient, you should not disseminate, distribute or copy this e-mail. Please notify the sender immediately and destroy all copies of this message and any attachments. If you have received this email in error, please promptly notify the sender by reply email and delete the original email and any backup copies without reading them.

Disclaimer:

This message was sent from Vellore Institute of Technology. The contents of this email may contain legally protected confidential or privileged information of "Vellore Institute of Technology". If you are not the intended recipient, you should not disseminate, distribute or copy this e-mail. Please notify the sender immediately and destroy all copies of this message and any attachments. If you have received this email in error, please promptly notify the sender by reply email and delete the original email and any backup copies without reading them.

Disclaimer:

This message was sent from Vellore Institute of Technology. The contents of this email may contain legally protected confidential or privileged information of "Vellore Institute of Technology". If you are not the intended recipient, you should not disseminate, distribute or copy this e-mail. Please notify the sender immediately and destroy all copies of this message and any attachments. If you have received this email in error, please promptly notify the sender by reply email and delete the original email and any backup copies without reading them.

 **Prof A.R. Ravishankara's visit to VIT (1).docx**
58K

Mausumi Goswami <mausumi.goswami@vit.ac.in>
To: Suphal Sen 22PHD0261 <suphal.sen2022@vitstudent.ac.in>

Tue, Mar 18, 2025 at 12:29 PM

----- Forwarded message -----

From: **Dr. Sainu Franco, International Relations Officer** <ir10@vit.ac.in>

Date: Mon, Oct 28, 2024 at 12:22 PM

Subject: Prof. A.R. Ravishankara's visit to VIT, Vellore

To: Director Centre for Clean Environment <director.cce@vit.ac.in>

Cc: Tamas Kumar Panda <tamaskumarpanda@vit.ac.in>, Mausumi Goswami <mausumi.goswami@vit.ac.in>, Dr.R.Seenivasan Director (IR) <director.ir@vit.ac.in>, Dr JNV Raghuram Asst Director- IR <ir3@vit.ac.in>, International Relations <international@vit.ac.in>

Dear Sir,

Prof. A. R. Ravishankara a member of the US National Academy of Science and a foreign member of the Royal Society (London) , is visiting VIT **on the 6th of November**. He currently chairs the Board on Atmospheric Science and Climate of the NAS and serves on the scientific advisory panel of the Climate Clean Air Coalition. He is also a recipient of several distinguished awards which include the Polanyi Medal of the Royal Society, The Stratospheric Ozone Protection award of the US Environmental Protection Agency, and the American Chemical Society's award for Creative Advances in Environmental Sciences. He has close to 400 publications and an h index of 101 (**CV is attached herewith**).

Wikipedia has some information on him: https://en.wikipedia.org/wiki/Akkihebbal_Ravishankara

His Google Scholar page: <https://scholar.google.com/citations?user=Gb0ClrsAAAAJ&hl=en>

<https://www.infosysprize.org/jury/2019/ravishankara.html>

In line with the visit, a seminar is being arranged on the 6th of November in Kamaraj Auditorium from the School of Advanced Sciences. Given his immense contribution to Climate Science and association with the United Nations Montreal protocol, an interaction session with him would be beneficial to CCE. I kindly request you to arrange an interaction with the faculty and researchers from CCE if possible.

DR. ELANGANNAN ARUNAN, Professor, Department of Inorganic and Physical Chemistry Indian Institute of Science Bangalore is also accompanying him. Please find attached both their CV's.

Kindly let me know your thoughts on this.

Warm regards,

Dr. Sainu Franco (Ms.)

International Relations Officer

O/o International Relations

Vellore Institute of Technology (VIT)

t: +91 416 2202074 / 2243118

e: ir10@vit.ac.in

e: outboundexchange@vit.ac.in

e: sainu.franco@vit.ac.in

Vellore - 632014 | Tamil Nadu, INDIA

www.vit.ac.in

Vellore Institute of Technology (VIT), India

Disclaimer:

This message was sent from Vellore Institute of Technology. The contents of this email may contain legally protected confidential or privileged information of "Vellore Institute of Technology". If you are not the intended recipient, you should not disseminate, distribute or copy this e-mail. Please notify the sender immediately and destroy all copies of this message and any attachments. If you have received this email in error, please promptly notify the sender by reply email and delete the original email and any backup copies without reading them.

--

Dr. Mausumi Goswami
Department of Chemistry
School of Advanced Sciences
Vellore Institute of Technology, vellore, India
Homepage: <https://mausumig.wixsite.com/research-page-mg>
Google Scholar Profile: <https://scholar.google.com/citations?user=jNvHLYwAAAAJ&hl=en>
"Being Challenged in Life is Inevitable, being defeated is optional"

2 attachments**Ravishankara-CV_9Jan2024_Long.doc**

217K

**arunan_cv_Sep2024.pdf**

390K

TAX INVOICE CUM DELIVERY CHALLAN

Stylzerz Gifts Inc. No.66, 1st Floor, Audiappa Naicken Street, Sowcarpet, Chennai -600 079 Contact: 044-43572376, 9840944623 E-Mail : Designerstylzerz@gmail.Com Tamil Nadu,India GSTIN/UIN: 33AGKPK6767C1ZC State Name : Tamil Nadu, Code : 33	Invoice No.	Dated
	9735	1-Nov-24
	Delivery Note	Mode/Terms of Payment
		IMED
	Reference No. & Date.	Other References
	9735 dt. 1-Nov-24	MURALI E - 9791037348
Buyer (Bill to)	Buyer's Order No.	Dated
VELLORE INSTITUTE OF TECHNOLOGY - VIT VELLORE Vellore-632014 Tamil Nadu - India GSTIN/UIN : 33AAATN0569M1ZE State Name : Tamil Nadu, Code : 33	MAIL	30-Oct-24
	Dispatch Doc No.	Delivery Note Date
	Dispatched through	Destination
	Terms of Delivery	

SI No.	Description of Goods	HSN/SAC	Quantity	Rate (Incl. of Tax)	Rate	per	Disc. %	Amount
1	TROPHY (2PCSET12%) 8306	8306	2 PCS	1,456.00	1,300.00	PCS		2,600.00
	Output CGST							156.00
	Output SGST							156.00
Total			2 PCS					₹ 2,912.00

Amount Chargeable (in words) E. & O.E

Indian Rupees Two Thousand Nine Hundred Twelve Only

HSN/SAC	Taxable Value	Central Tax		State Tax		Total Tax Amount
		Rate	Amount	Rate	Amount	
8306	2,600.00	6%	156.00	6%	156.00	312.00
Total	2,600.00		156.00		156.00	312.00

Tax Amount (in words) : **Indian Rupees Three Hundred Twelve Only**

Company's Bank Details

A/c Holder's Name: **Stylzerz Gifts Inc.**

Bank Name : **Indian Overseas Bank**

A/c No. : **008602000010475**

Branch & IFS Code: **Sowcarpet Br. & IOBA0000086**

Declaration

We declare that this invoice shows the actual price of the goods described and that all particulars are true and correct.

for Stylzerz Gifts Inc.

Authorised Signatory

This is a Computer Generated Invoice



VIT

Vellore Institute of Technology
(Instituted to be a University under section 3 of U.G.A. Act, 1956)

Template
for Events
Organized

SCHOOL OF ADVANCED SCIENCES PROGRAM DETAILS

Event type	Ideation		
Title of the event	Yantra'25 - AI for Resilient Cities: "Engineering Sustainability and Climate Harmony"		
Date (From - To)	08.02.2025		
Time	10:00 AM - 01:00 PM		
Venue	TT Kamaraj Auditorium		
No. of Participants	18 participants		
Coordinator(s)	Emp. ID.	Faculty Name	Department
	11890	Dr. Sai Saraswathi V	SAS
Resource Person Name	NIL		
Designation	Faculty Coordinator		
Organization Details	Nature Club, VIT		
Place	Vellore		
E-mail	v.saisaraswathi@vit.ac.in		
Mobile no.	91 89037 61281		

Signature of the Coordinator

Signature of the Dean / Director

Dean
School of Advanced Sciences
Vellore Institute of Technology
(Instituted to be a University under section 3 of U.G.A. Act, 1956)
Vellore - 632 014, Tamil Nadu, India

PROGRAMME SCHEDULE

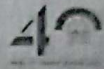

OFFICE OF STUDENTS' WELFARE



NATURE CLUB

AI FOR RESILIENT CITIES

ENGINEERING SUSTAINABILITY AND CLIMATE HARMONY



8TH FEBRUARY 2025



10:00 AM TO 1:00 PM



KAMARAJ AUDITORIUM

STUDENT COORDINATOR DETAILS :

Nivethitha D - +91 93428 08897

Abhinav S - +91 89394 09600

For more information contact : yantra.sw@vit.ac.in



NATURECLUBVIT



NATURECLUB@VIT.AC.IN



NATURECLUBVIT

A REPORT ON NATURE'S BLUEPRINT

The Nature Lovers Club hosted an exhilarating Ideathon titled "AI for Resilient Cities: Engineering Sustainability and Climate Harmony" on 8th February 2025 at Kamaraj Auditorium. The event explored AI's role in urban sustainability and climate resilience, aligning with SDG 11 & SDG 13. Participants engaged in discussions on AI-driven solutions to address contemporary urban challenges.

The event began at 10:00 AM with a welcome speech, emphasizing AI's potential in creating disaster-ready and eco-friendly cities. 30 participants received problem statements inspired by SDG 11 and SDG 13, forming the basis of their projects. Teams registered on the Interact platform to access challenges and began brainstorming AI-driven solutions. Teams developed ideas focusing on AI integration in smart infrastructure, disaster mitigation, and sustainable urban planning. In the second phase, teams presented their solutions to judges, evaluated on innovation, feasibility, and impact. The event concluded at 1:00 PM with a vote of thanks and a recognition ceremony.

The Ideathon fostered creativity and environmental awareness. By integrating AI with sustainability, participants showcased its potential in building resilient cities, reinforcing the club's mission of driving positive change.

GEOTAGGED PHOTOS

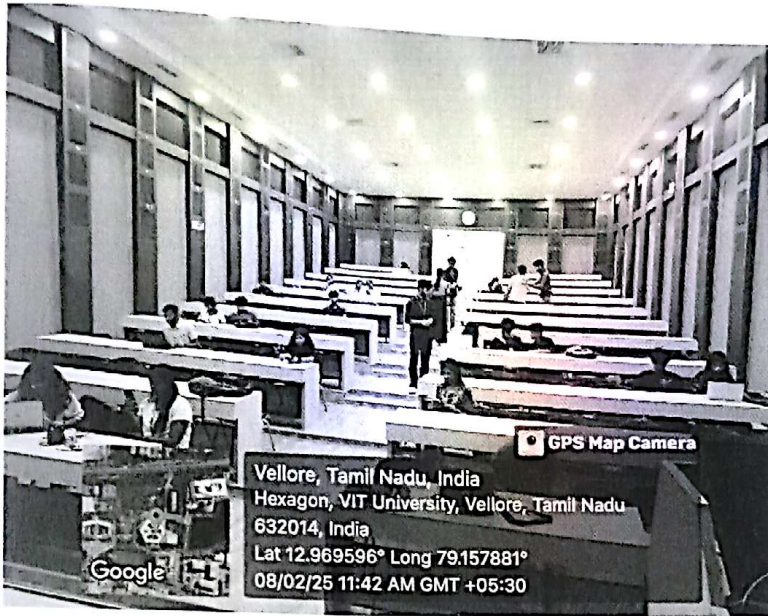



Centre for Nanobiotechnology & TLCE

VALUE ADDED / GUEST LECTURE / SEMINAR / WORKSHOP / SYMPOSIUM / CONFERENCE / TRAINING PROGRAM DETAILS

Event type	Faculty Development Program		
Title of the event	Microplastics as an Emerging Pollutant		
Date (From – To)	15-Nov-2024		
Time	10.00 A.M to 5.00 P.M		
Venue	TT725		
No. of Participants	58		
Coordinator(s)	Emp. ID.	Faculty Name	Department
	13638	Dr. John Thomas	CNBT
	20206	Dr. Krishna Rao Eswar N	CNBT
Resource Person Name	Dr S Sahabudeen		
Designation	Associate Professor and Head		
Organization Details	Dept. of Biotechnology, SRM Chennai		
Place	Chennai		
E-mail	sahabuds@srmist.edu.in		
Mobile no.	7358982752		
Resource Person Name	Dr Sundaramanickam		
Designation	Associate Professor		
Organization Details	Annamalai University		
Place	Parangipettai		
E-mail	fish_lar@yahoo.com		

Mobile no.	9486456460
Resource Person Name	Dr Vinay Kumar
Designation	Professor
Organization Details	Saveetha Medical College and Hospital, SIMATS
Place	Chennai
E-mail	vinaykumar.smc@saveetha.com
Mobile no.	9810975503
Resource Person Name	Dr Abdel
Designation	Professor
Organization Details	National Research Centre
Place	Egypt
E-mail	abdeltawab.mossa@yahoo.com
Mobile no.	2020100503850

John Thomas 

Signature of the Coordinator

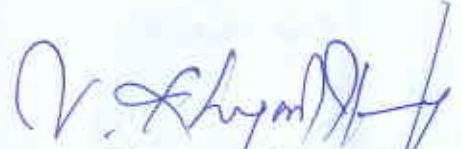

Signature of the Dean / Director
 Director
 Teaching Learning Centre of Excellence
 VIT, Vellore - 632 014.



Dr. Thenmozhi M
 Assistant Director
 Teaching Learning Centre of Excellence (TLCE)
 Vellore Institute of Technology (VIT)
 (Deemed to be University under section 3 of the UGC Act, 1956)
 Vellore - 632 014, TN, India.

Brochure / Circular of the Event / Programme Schedule



VIT[®]
Vellore Institute of Technology
(Deemed to be University under section 3 of UGC Act, 1956)

CENTRE FOR NANOBIO TECHNOLOGY

Invites you all for

A One-day Faculty Development Program on

Microplastics as an Emerging Pollutant

November 15, 2024, Venue: TT 725, Time: 9:30 A.M.

Resource Persons

Dr. A. Sundaramanickam
Associate Professor
Faculty of Marine Sciences
Annamalai University, Tamil Nadu,
India

Dr. S. Sahabudeen
Associate Professor & Head
Dept. of Biotechnology
SRMIST, Tamil Nadu,
India

Dr. Vinay Kumar
Professor
Dept. of Community Medicine
Saveetha Medical College & Hospital
SIMATS, Tamil Nadu, India

Dr. Abel-Tawab H. Mossa
Professor
Environmental Toxicology Research Unit,
National Research Centre
Egypt

Co-ordinators

Dr. John Thomas
Associate Professor (Gr-II)
CNBT, VIT

Dr. N. Krishna Rao Eswar
Associate Professor (Gr-I)
CNBT, VIT



VIT[®]

Vellore Institute of Technology
(Deemed to be University under section 3 of UGC Act, 1956)

CENTRE FOR NANOBIO TECHNOLOGY

Invites you all for

A One-day Faculty Development Program on

Microplastics as an Emerging Pollutant

November 15, 2024, Venue: TT 725, Time: 9:30 A.M.

Program Schedule

Time	Lecture
9:30 a.m. - 11:00 a.m	Microplastics in Aquatic Ecosystems: Impacts and Consequences
11:30 a.m. - 1:00 a.m	Impact of microplastic on ecosystem and in vivo toxicity testing in the Drosophila melanogaster model
2:00 p.m - 3:30 p.m	Emergence and Persistence of Microplastic residues in clinical samples: Exposure routes, detection methods and human toxicity
4:00 p.m. - 5:30 p.m.	Ecotoxicology of pesticides : The impact of micro and nanoplastics

A REPORT ON

MICROPLASTICS AS AN EMERGING POLLUTANT

The Faculty Development Program (FDP) on microplastic pollution undoubtedly provided participants with a thorough understanding of a significant environmental issue with present-day urgency. The program provided participants with an in-depth knowledge of the origins, distribution patterns, and effects of microplastics, enhancing their awareness of the scope and complexities of this problem. Participants looked into the mechanisms by which microplastics permeate ecosystems, assessing their toxicity and prevalence in various environments, including oceans and agricultural soils. The program addressed the challenges associated with controlling microplastic contamination, proposing solutions. This FDP has provided the faculties and researchers with insights on how to reduce microplastics in everyday life leading towards a sustainable future.

PROGRAM AT A GLIMPSE

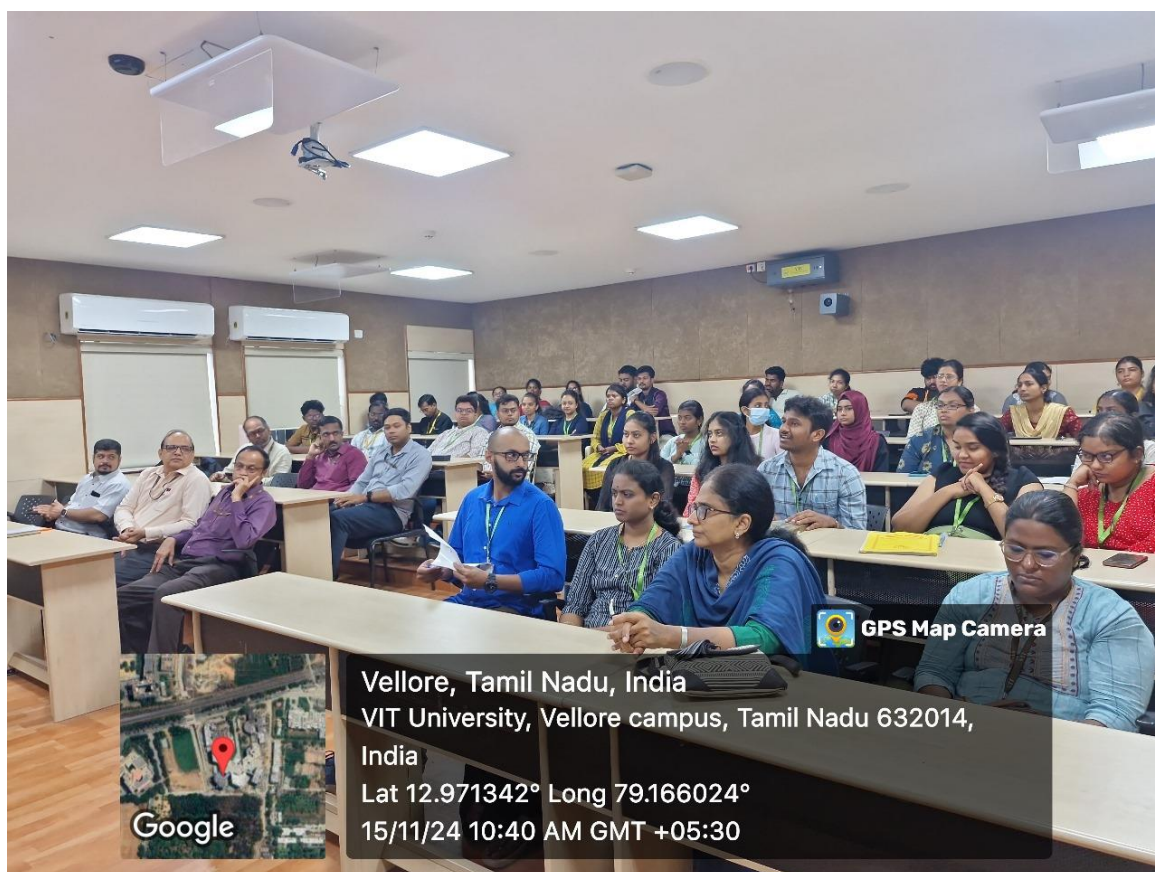





Vellore, Tamil Nadu, India
X5C6+925 Technology Tower Annexe, VIT University, Vellore, Tamil Nadu 632014, India
Lat 12.970938°
Long 79.159711°
15/11/24 02:18 PM GMT +05:30

GPS Map Camera



Vellore, Tamil Nadu, India
VIT University, Vellore campus, Tamil Nadu 632014,
India
Lat 12.971342° Long 79.166024°
15/11/24 03:31 PM GMT +05:30

GPS Map Camera



TLCE & CO₂

Research and

Green Technologies Centre

TRAINING PROGRAM DETAILS

Event type	Faculty Development Program (FDP)		
Title of the event	Advanced Functional Materials on Energy and Healthcare Applications		
Date (From – To)	23.6.2025 – 27.6.2025		
Time	10.00- 5.30 pm		
Venue	MB 210		
No. of Participants	23		
Coordinator(s)	Emp. ID.	Faculty Name	Department
	18925	Dr. Rameshkumar Singh	CO₂ Research and Green Technologies Center.
	12575	Dr. Kavitha M.S	CO₂ Research and Green Technologies Center.
Resource Person Name	Dr. D. Ravi Shankaran, Dr Kavitha Shankar Narayana, Prof. M. Sathish, Prof. Satyen Saha, Dr Elumalai P, Dr. Kavita Joshi, Prof. V. Dharuman		
Designation	Professor, Principal Investigator, Principal Scientist, Professor, Professor, Principal Scientist, Professor.		
Organization Details	VIT		
Place	Vellore		
E-mail	rameshkumar.singh@vit.ac.in , Kavitha.ms@vit.ac.in		
Mobile no.	9956054815, 9597285814		

Signature of the Coordinator

Signature of the Dean / Director

Brochure / Circular of the Event / Programme Schedule



Teaching Learning Centre of Excellence (TLCE)

in association with

CO₂ Research and Green Technologies Centre [CO₂]

Cordially invites you for the

5- Day Faculty Development Programme [FDP]

on

Advanced Functional Materials on Energy and Healthcare Applications

Event Coordinators:

Dr. RAMESH KUMAR SINGH, CO₂

Dr. KAVITHA M S, CO₂

Date : 23rd to 27th June, 2025

Time : 10.00 am to 5.30 pm

Venue : MB 210

R. Senthil Kumar
Director - TLCE

Session	Topic	Date /venue	Time	Resource person
Session 1	Functional Nanomaterials for Supercapacitor Applications (Overview of Supercapacitors)	23.6.25, MB 210	10.00 -11.30	Dr. Senthil Kumar Annamalai VIT, Vellore.
Session 2	Turning Waste to Watts: Biogas Production from Institutional Food Waste	23.6.25, MB 210	11.45 -1.15	Dr. S.Murugavelh VIT, Vellore.
Session 3	Engineering Functional Materials for Energy: Degradation Modes and Testing Strategies of PGM catalyst layers in PEM Fuel Cells	23.6.25, MB 210	2.15 – 3.45	Dr. Shankar Raman Dhanushkodi. VIT, Vellore
Session 4	Tailor-Made Functional Materials as Solid-State Optical Sensors and New-Age Photocatalysts for Environment and Resource Recovery Applications	23.6.25, MB 210	4.00 - 5.30	Prof. Prabhakaran D VIT, Vellore.
Session 5	Overview of Nanobiosensors	24.6.25, MB 210	10.00 -11.30	Dr. D. Ravi Shankaran University of Madras.
Session 6	Functional Nanocarriers for Sustainable Healthcare	24.6.25, MB 210	11.45 -1.15	Dr. D. Ravi Shankaran University of Madras.
Session 7	Biotechnology Systems in Healthcare Applications	24.6.25, MB 210	2.15 - 3.45	Dr Kavitha Shankar Narayana, Anna University
Session 8	Biotechnology Systems in Healthcare Applications	24.6.25, MB 210	4.00 - 5.30	Dr Kavitha Shankar Narayana, Anna University
Session 9	Energy storage in supercapacitors	25.6.25, MB 210	10.00 -11.30	Prof. M. Sathish, CECRI, Karikudi
Session 10	Wearable Sensors for Health Monitoring	25.6.25, MB 210	11.45 -1.15	Prof. Kathirvelan J
Session 11	a. Chemical Tuning of Functional Materials for Selected Applications. b. Advanced Biomaterials for Healthcare Applications	25.6.25, MB 210	2.15 - 3.45	a.Prof. Vijayaraghavan R VIT Vellore. b.Prof. Siva Ramamoorthy, VIT Vellore

Session 12	Towards a better understanding of Luminescence properties of Lanthanide-ligand complexes and Nanocrystalline materials	25.6.25, MB 210	4.00 - 5.30	Prof. Satyen Saha Institute of Science, Banaras Hindu University
Session 13	Bioenergy production and CO ₂ sequestration to value-added products	26.6.25, MB 210	10.00 -11.30	Prof. G Velvizhi, VIT Vellore
Session 14	Comparison of lead-based and lead-free piezoelectric nanogenerators for real-time	26.6.25, MB 210	11.45 -1.15	Prof. Madhuri W, VIT Vellore
Session 15	Energy Materials for Batteries	26.6.25, MB 210	2.15 – 3.45	Dr.Elumalai P Pondhicherry University
Session 16	Energy Materials for Batteries	26.6.25, MB 210	4.00 - 5.30	Dr.Elumalai P Pondhicherry University
Session 17	Catalyzing innovation through computation	27.6.25, MB 210	10.00 -11.30	Dr. Kavita Joshi CSIR-National Chemical Laboratory, Pune
Session 18	Nanomaterials in Biosensor and Bioelectronics Applications	27.6.25, MB 210	11.45 -1.15	Prof. V. Dharuman Alagappa University
Session 19	Nanomaterials in Biosensor and Bioelectronics Applications	27.6.25, MB 210	2.15 - 3.45	Prof. V. Dharuman Alagappa University
Session 20	Nanomaterials in Biosensor and Bioelectronics Applications	27.6.25, MB 210	4.00 - 5.30	Prof. V. Dharuman Alagappa University

A REPORT ON (FDP) - Advanced Functional Materials on Energy and Healthcare Applications

The development of advanced functional materials has become pivotal in addressing the pressing global challenges in energy sustainability and healthcare innovation. This Faculty Development Program (FDP) titled "Advanced Functional Materials for Energy and Healthcare Applications" is designed to provide interdisciplinary insights into the latest trends, breakthroughs, and prospects of material science and its applications across energy storage, conversion technologies, and biomedical solutions. The program will cover a broad spectrum of topics including, but not limited to, nanostructured materials, energy storage systems (such as batteries and supercapacitors), energy harvesting technologies, biomaterials for drug delivery, diagnostic platforms, and tissue engineering. Through expert-led lectures, interactive sessions, and hands-on demonstrations, participants will gain a deeper understanding of the synthesis, characterization, and real-world integration of functional materials. This FDP aims to foster a collaborative platform for faculty from science and engineering backgrounds, encouraging cross-disciplinary engagement and knowledge sharing. Participants will also be exposed to the latest tools, research methodologies, and funding opportunities in this rapidly evolving field, ultimately enhancing their teaching and research capabilities.

Geo tagged pictures of the event

Day 1: Functional Nanomaterials for Supercapacitor Applications (Overview of Supercapacitors), 23.6.25, 10.00-11.30, Dr. SenthilKumar Annamalai, VIT, Vellore

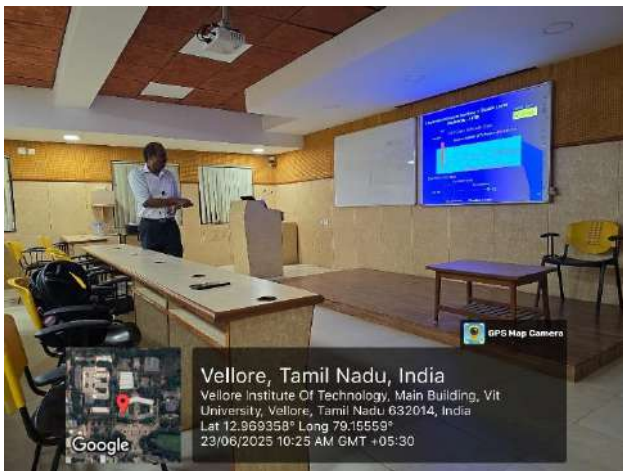

Day 1: Turning Waste to Watts: Biogas Production from Institutional Food Waste, 23.6.25, 11.45-1.15, Dr. S.Murugavelh, VIT, Vellore.



Day 1: Engineering Functional Materials for Energy: Degradation Modes and Testing Strategies of PGM catalyst layers in PEM Fuel Cells, 23.6.25, 2.15-3.45, Dr. Shankar Raman Dhanushkodi, VIT Vellore.

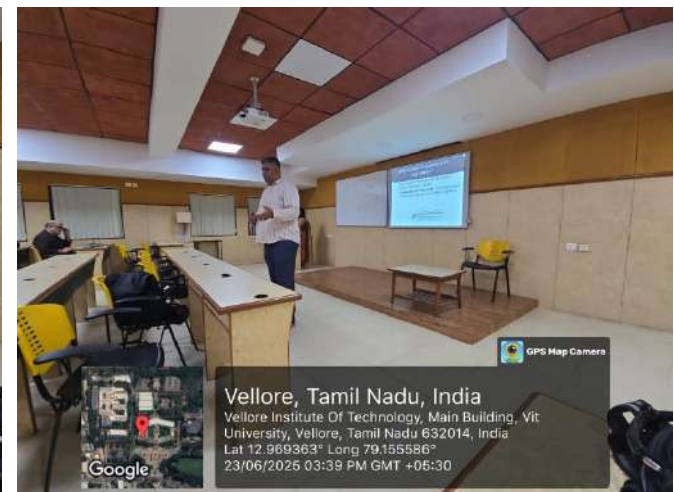
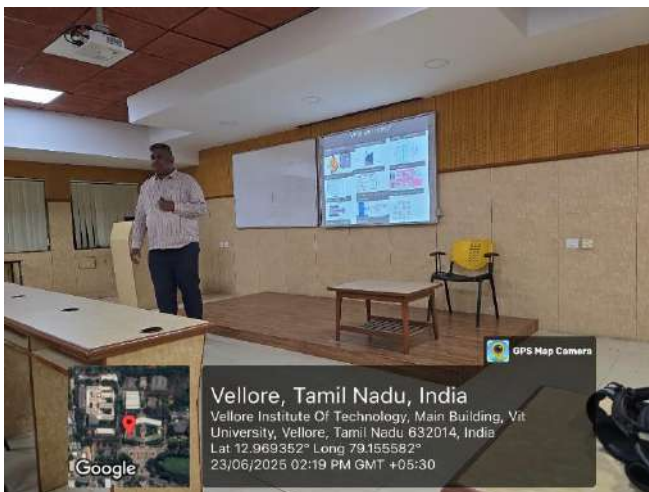

Day 1: Tailor-Made Functional Materials as Solid-State Optical Sensors and New-Age Photocatalysts for Environment and Resource Recovery Applications, 23.6.25, 4.00-5.30, Prof. Prabhakaran D, VIT, Vellore.



Day 2: Overview of Nanobiosensors, 24.6.25, 10.00-11.30, Dr. D. Ravi Shankaran, University of Madras



Day 2: Functional Nanocarriers for Sustainable Healthcare, 24.6.25 11.45-1.15, Dr. D. Ravi Shankaran, University of Madras



Day 2: Biotechnology Systems in Healthcare Applications, 24.6.25, 2.15-3.45, Dr Kavitha Shankar Narayana, Anna University

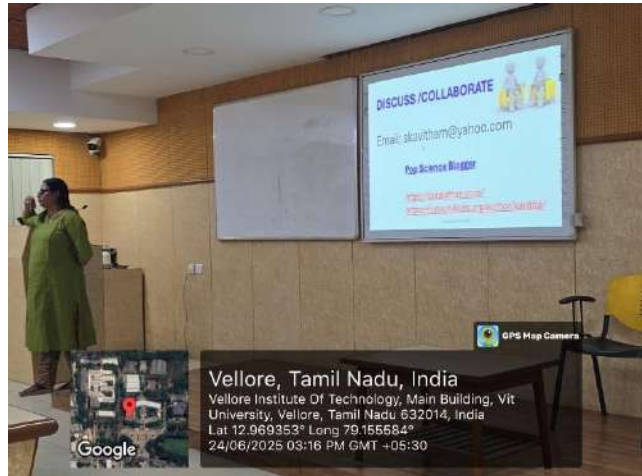

Day 2: Biotechnology Systems in Healthcare Applications, 24.6.25, 4.00-5.30, Dr Kavitha Shankar Narayana, Anna University



Day 3: Energy storage in supercapacitors, 25.6.25, 10.00-11.30, M. Sathish, CECRI, Karikudi.

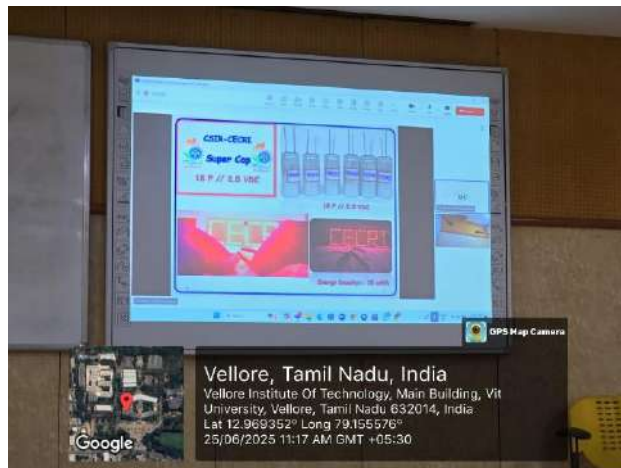
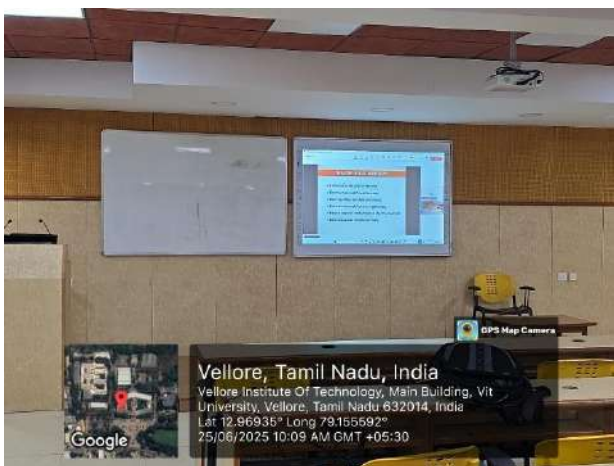

Day 3: Wearable Sensors for Health Monitoring, 25.6.25, 11.45-11.30, Prof. Kathirvelan J, VIT, Vellore.



Day 3: a. Chemical Tuning of Functional Materials for Selected Applications b. Advanced Biomaterials for Healthcare Applications, 25.6.25, 2.15-3.45, a.Prof. Vijayaraghavan R VIT Vellore. b. Prof. Siva Ramamoorthy, VIT Vellore

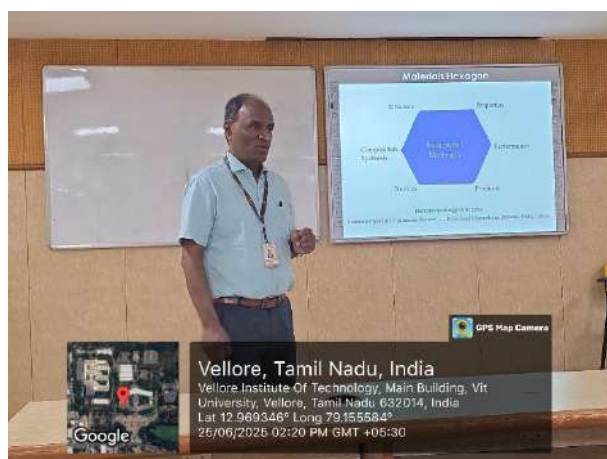

Day 3: Towards a better understanding of Luminescence properties of Lanthanide-ligand complexes and Nanocrystalline materials, 25.6.25, 4.00-5.30, Prof. Satyen Saha Institute of Science, Banaras Hindu University.

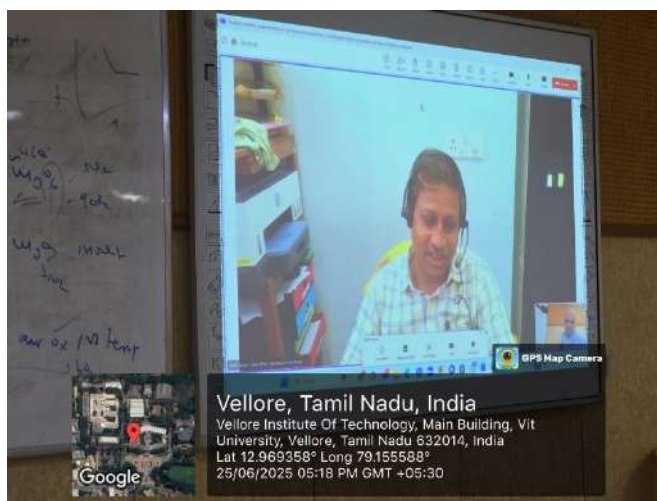
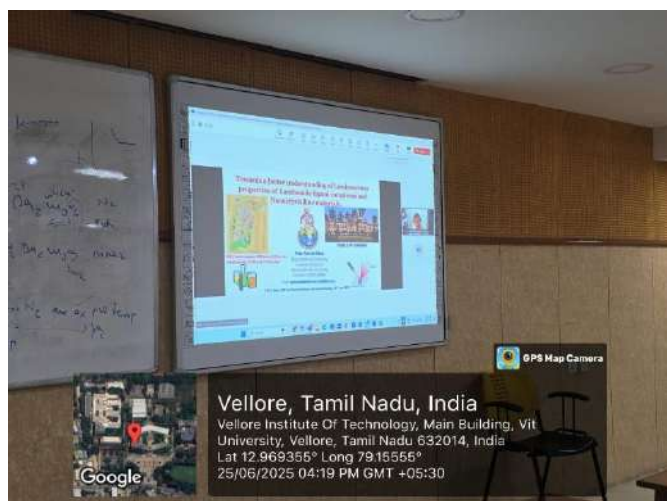

Day 4: Bioenergy production and CO₂ sequestration to value-added products, 26.6.25, 10.00-11.30, Dr. G Velvizhi, VIT Vellore.



Day 4: Comparison of lead-based and lead-free piezoelectric nanogenerators for real-time, 26.6.25, 11.45-1.15, Prof. Madhuri W, VIT Vellore



Day 4: Energy Materials for Batteries, 26.6.25, 2.15-3.45, Dr.Elumalai P, Pondhicherry Universit



Day 4: Energy Materials for Batteries, 25.6.25, 4.00-5.30, Dr.Elumalai P, Pondhicherry University



Day 5: Catalyzing innovation through computation, 27.6.25, 10.00-11.30, Dr. Kavita Joshi, CSIR-National Chemical Laboratory, Pune

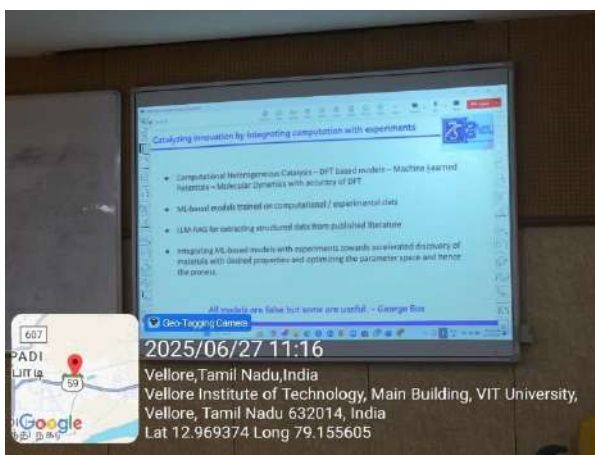

Day 5: Nanomaterials in Biosensor and Bioelectronics Applications, 27.6.25, 11.45-1.15, Prof. V. Dharuman, Alagappa University.

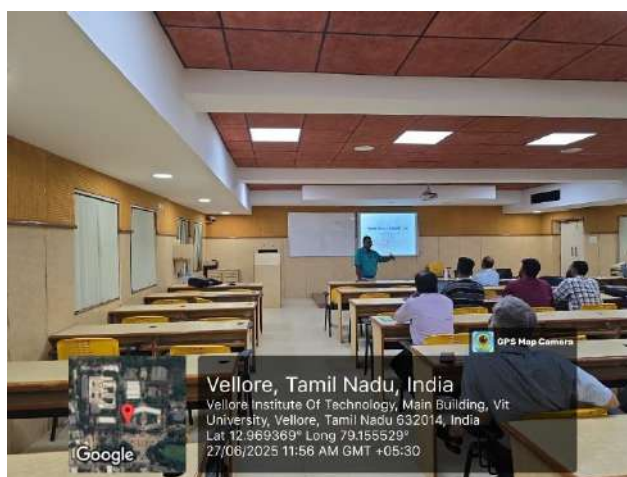

Day 5: Nanomaterials in Biosensor and Bioelectronics Applications, 27.6.25, 2.15-3.15, Prof. V. Dharuman, Alagappa University.



Day 5: Nanomaterials in Biosensor and Bioelectronics Applications, 27.6.25, 4.30-5.30, Prof. V. Dharuman, Alagappa University.



Group Picture of Participants



Expenditure / Revenue Details of the Event

S.no	Resource person name	Ticket no	Date of submission	Honorarium	Transport	
1	Dr. Ravi Shankaran		27.6.25	6000	2742(cab fees)+581 (train) = 3323	
2	Dr.N.Kavitha shankar Narayana		27.6.25	6000	137.5+137.5= 275km (275*9= 2475 rs) = 2475	
3	Dr.Sathish	-	27.6.25	3000	0	
4	Dr.Satyen saha	-	27.6.25	3000	0	
5	Dr.Elumalai		27.6.25	6000	Fuel = 2020, Toll charges= 65+70 (rs) =2155	
6	Dr. Kavitha Joshi	-	27.6.25	3000	0	
7	Dr.V.Dharuman		27.6.25	9000	1574+ 1574 (Bus ticket) =3148	
				Total	36000	11,101

Signature of the Coordinator

Signature of the Dean / Director

QUIZ (10 MARKS)

- **Event CO:** To utilize nanomaterials in energy sensors and biogas applications.
- Functional materials and their use in healthcare applications
- The role of functional materials for electronics and biomedical applications.
- To understand the role of functional materials for bio-sensors and bio-electronics
- To learn the fundamental concepts in catalysis and computational innovation.



SELECT & TLCE

TRAINING PROGRAM DETAILS

Event type	Faculty Development Program		
Title of the event	Sustainable Smart Cities: The Role of Smart Grids, EVs, and Green Hydrogen		
Date (From – To)	05-05-2025 to 09.05.2025 (5 days)		
Time	10.00 am to 05.30 pm		
Venue	TT311		
No. of Participants	68		
Coordinator(s)	Emp. ID.	Faculty Name	Department
	15251	Prof. BRISILLA R M	SELECT
	11075	Prof. SANKARDOSS V	SELECT
Resource Person Name	1. Dr. Vignesh Kumar V, 2. Dr. A. Karthikeyan, 3. Dr. E V S Kiran Kumar Donthu, 4. Dr. M. P. Selvan, 5. Dr. Subhasis Mandal, 6. Dr. Jaganathan VM, 7. Dr. Vanchiappan Aravindan, 8. Dr. Srinivas Nayak, 9. Dr. B. Chitti Babu, 10. Dr. M. M. Rajan Singaravel		
Designation	Professors		
Organization Details	1. NIT, Trichirappalli, 2. NIT Karnataka, Surathkal, 3. IIT BHU Varanasi, 4. NIT, Trichirappalli, 5. NIT Calicut, 6. NIT Tiruchirappalli, 7. IISER Tirupati, 8. NIT Tiruchirappalli, 9. IIITDM Kancheepuram, 10. NIT Puducherry, Karaikal		
Place	VIT University		
E-mail	brisilla.rm@vit.ac.in , vsankardoss@vit.ac.in		
Mobile no.	8248691805, 8825965509		

R.M. Brisilla *Sankardoss*

Signature of the Coordinator

1. Dr. R.M. Brisilla (SELECT/15251)
2. Dr. V. Sankardoss (SELECT/11075)

For The Dean

Signature of the Dean / Director

Director
Teaching Learning Centre of Excellence
VIT, Vellore - 632 014

Event Brochure / Schedule

Date	Session I	Session II	Session III	Session IV
	[10 am to 11.30 am]	[11.45 am to 1.15 pm]	[2.15 pm to 3.45 pm]	[4 pm to 5.30 pm]
	Name of the Resource Person [mention external or internal]			
5/5/2025	Dr B Venkatesaperumal	Dr B Venkatesaperumal	Dr A Karthikeyan	Dr A Karthikeyan
5/6/2025	Dr D E V S Kiran Kumar	Dr D E V S Kiran Kumar	Dr. M. P. Selvan	Dr. M. P. Selvan
5/7/2025	Dr Subhasis Mandal	Dr Subhasis Mandal	Dr Jaganathan VM	Dr Jaganathan VM
5/8/2025	Dr Vanchiappan Aravindan	Dr Vanchiappan Aravindan	Dr Srinivasa Rao Nayak	Dr Srinivasa Rao Nayak
5/8/2025	Dr Chitti Babu	Dr Chitti Babu	Dr M M Rajan Singaravel	Dr M M Rajan Singaravel

A REPORT ON

Sustainable Smart Cities: The Role of Smart Grids, EVs, and Green Hydrogen

The document titled “*Sustainable Smart Cities: The Role of Smart Grids, EVs, and Green Hydrogen*” outlines a comprehensive series of lectures delivered by multiple experts, each addressing key technologies and innovations crucial for sustainable urban development.

A. Karthikeyan delivers two technical sessions. The first is on Sensorless Control of Permanent Magnet Synchronous Motors (PMSMs), essential for improving efficiency and reliability in electric vehicles and industrial automation by eliminating the need for mechanical sensors. His second session explores Power Conditioning in Smart Grids, emphasizing the use of devices like Dynamic Voltage Restorers (DVRs) and Phase-Locked Loops (PLLs) to enhance grid stability and quality through advanced electronics.

Dr. V. Vignesh Kumar focuses on the Power Converters for EV Charging Systems, discussing the different converter types, their role in grid integration, and practical deployment considerations. His second topic is Gate Driver Requirements for Power Converters, explaining their role in ensuring efficient and safe operation of high-frequency, high-voltage systems, with attention to design and protective features.

Dr. D. E. V. S. Kiran Kumar presents two lectures under the umbrella of Urban Heat Mitigation in Sustainable Smart Cities, with a focus on Singapore’s tropical climate. The first session emphasizes data collection and modeling to address the urban heat island effect. The second session offers technological solutions like cool roofs, green infrastructure, and smart urban design to enhance urban resilience and livability.

Prof. M. P. Selvan discusses energy demand and market innovation. His first lecture covers Demand Response and Peer-to-Peer Energy Trading, highlighting how real-time demand balancing and decentralized trading platforms empower consumers as “prosumers.” The second lecture addresses the Impact of EV Charging on Power Demand, offering strategies like load forecasting and integration of renewable energy to mitigate grid stress.

Dr. Subhasis Mandal explores Hydrogen Production and Storage as a pillar of clean energy transition. He explains multiple production pathways, especially green hydrogen, and storage technologies such as compressed gas, liquid hydrogen, and metal hydrides, focusing on their roles in transportation, industry, and energy systems.

Dr. V. M. Jaganathan builds on this with two lectures: one on Green Hydrogen Generation Methods using solar and wind power, and another on Hydrogen Storage and Utilization Techniques, emphasizing practical and scalable storage methods for various applications.

Dr. Vanchiappan Aravindan delivers a session on Electrochemical Energy Storage Systems, detailing the development and classification of batteries, supercapacitors, and fuel cells. He also discusses the Recycling of Li-ion Batteries, including graphite recovery, second-life applications, and new uses in alternative battery chemistries.

Dr. Srinivas Rao Nayak focuses on EV Charging Infrastructure, first detailing plug-in systems, including standards and grid integration. His second lecture explores Wireless Charging for EVs, an emerging technology aimed at user convenience and seamless grid interaction.

Dr. B. Chitti Babu presents on Control and Grid Integration of Solar PV Systems, discussing control strategies like Maximum Power Point Tracking (MPPT) and challenges in integrating solar energy with the grid to ensure reliability and efficiency.

Lastly, Dr M M Rajan Singaravel delivers Renewable energy integration and Photovoltaic research and grid compatibility.

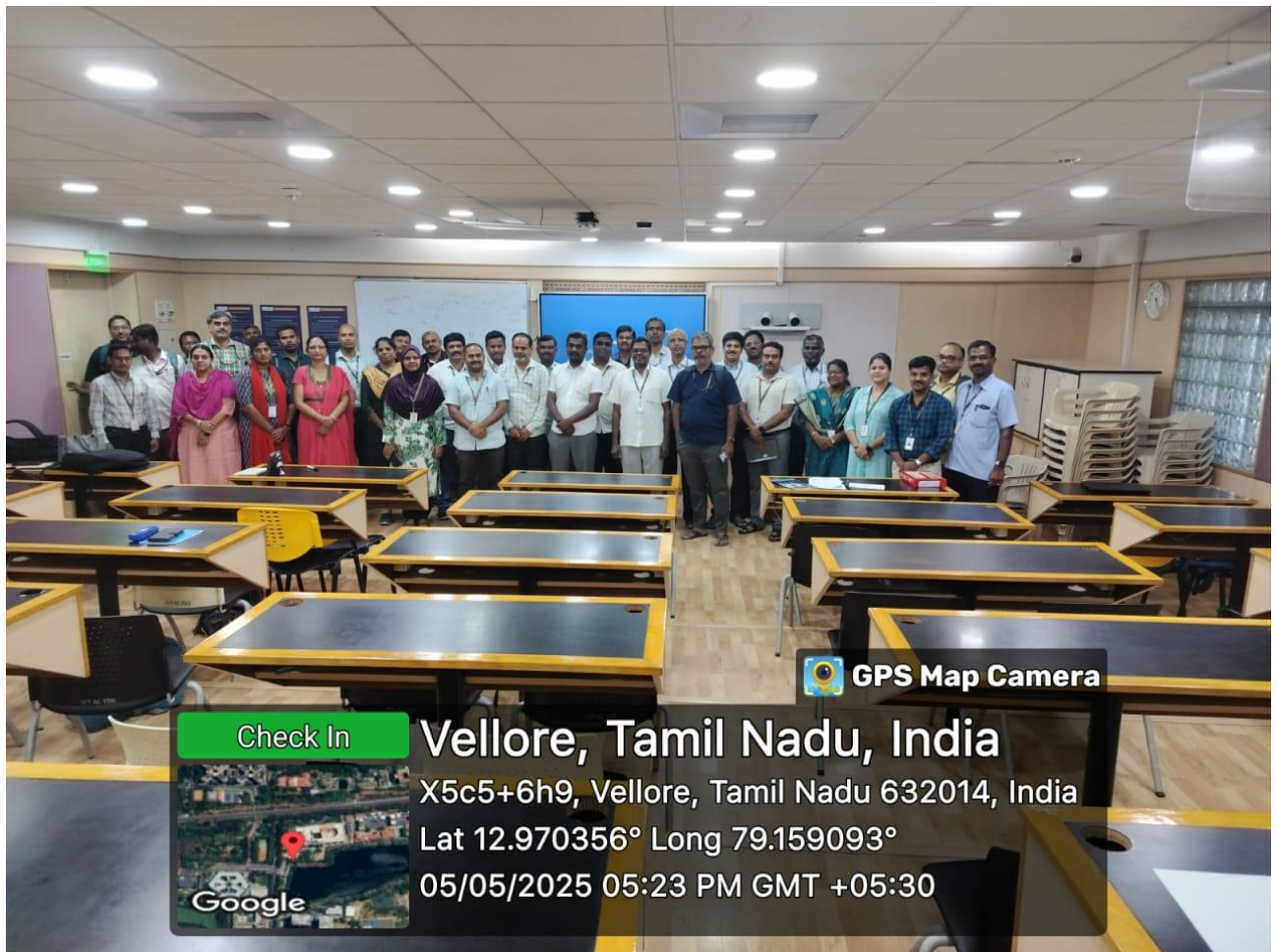

GPS Map Camera



Check In

Vellore, Tamil Nadu, India

X5c5+6h9, Vellore, Tamil Nadu 632014, India

Lat 12.970356° Long 79.159093°

05/05/2025 05:23 PM GMT +05:30

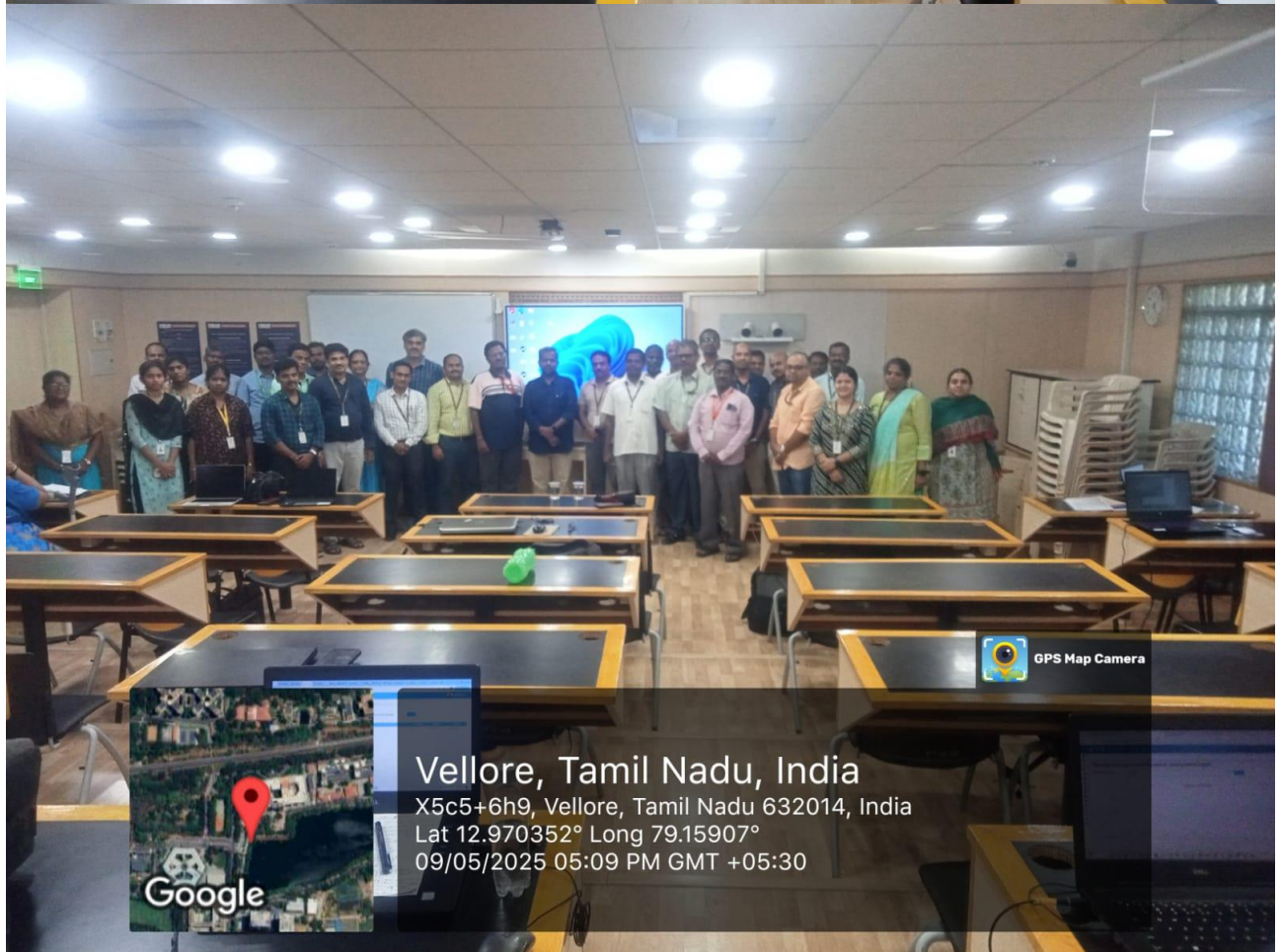

GPS Map Camera



Vellore, Tamil Nadu, India

X5c5+6h9, Vellore, Tamil Nadu 632014, India

Lat 12.970352° Long 79.15907°

09/05/2025 05:09 PM GMT +05:30

Expenditure / Revenue Details of the Event

Sl. No.	Name of RP	Ticket No.	Date of Submission	Honorarium	Transport	Accommodation	Total Amount (in Rs.)
1	Dr. V Vignesh Kumar	48739	12.06.2025	6000	4542	0	10542
2	Dr. A Karthikeyan	48741	12.06.2025	6000	3220	0	9220
3	Dr. D E V S Kiran Kumar	48744	12.06.2025	6000	8245	0	14245
4	Dr. M P Selvan	48745	12.06.2025	6000	3366	0	9366
5	Dr. Subhasis Mandal	48746	12.06.2025	6000	3941	0	9941
6	Dr. Jaganathan V M	48747	12.06.2025	6000	2308	0	8308
7	Dr. Aravindan V	48748	12.06.2025	6000	2376	0	8376
8	Dr. P Srinivasa Rao Nayak	48749	12.06.2025	6000	7200	0	13200
9	Dr. B Chitti Babu	48750	12.06.2025	6000	3360	0	9360
10	Dr. M M Rajan Singaravel	48751	12.06.2025	6000	3384	0	9384
11	Dr. Sankardoss V [11075]	48752	12.06.2025	0	0	4480	4480
						Grand Total	106422

R. M. Brisille 

Signature of the Coordinator

Fr. Theodor 

Signature of the Dean / Director

Director
Teaching Learning Centre of Excellence
VIT, Vellore - 632 014



VIT[®]

Vellore Institute of Technology
(Deemed to be University under section 3 of UGC Act, 1956)

CO2 Research and Green Technologies Centre & TLCE

TRAINING PROGRAM DETAILS



Event type	Faculty Development Program		
Title of the event	Low-temperature Fuel Cells for Electrochemical Propulsion: Fundamentals, Major Components, Cell Fabrication and Real-time Applications		
Date (From – To)	March 12, 2025		
Time	10:00 am to 11:30 am		
Venue	TT707		
No. of Participants	36		
Coordinator(s)	Emp. ID.	Faculty Name	Department
	18925	Ramesh Kumar Singh	CO2
Resource Person Name	Dr. Ramesh Kumar Singh		
Designation	Assistant Professor, Sr. Grade II		
Organization Details	VIT Vellore		
Place	Vellore		
E-mail	rameshkumar.singh@vit.ac.in		
Mobile no.	+919956054815		

Signature of the Coordinator

Signature of the Dean / Director
Director o(i/c)
Teaching Learning Centre of Excellence
VIT, Vellore - 632 014.

Brochure / Circular of the Event / Programme Schedule



	<h2>Faculty Development Program</h2>	
<p>Title : Low-temperature Fuel Cells for Electrochemical Propulsion: Fundamentals, Major Components, Cell Fabrication and Real-time Applications</p> <p>Date : 2025-03-12 - 2025-03-12 Time : 10:00 - 11:30 Venue : TT 707</p>	<p style="text-align: center;">Event Outcome</p> <p>- Participants get exposure to fuel cell research</p>	
	<p>Resource Person 1 - Details Name : Ramesh Kumar Singh Designation : Assistant Professor Sr. Grade 2, CO2 Research and Green Technologies Centre University/ Company : VIT, Vellore Address : India, 632014.</p>	
<p>Resource Person's Profile :</p> <p>I. Profile of Ramesh Kumar Singh Dr. Ramesh Kumar Singh is an Assistant Professor in the CO2 Research and Green Technologies Centre at Vellore Institute of Technology (VIT), Vellore, India. Prior to joining VIT, he was a Postdoctoral Fellow at Technion-Israel Institute of Technology and Ariel University, Israel. His research interests are in developing electrode materials for hydrogen generation, urea oxidation reaction, HOR, support materials, and electrolytes for fuel cells, electrolyzers and metal-air batteries.</p> <p>Fuel cells are direct electrochemical energy conversion devices since they convert chemical energy to electricity without emitting any carbon dioxide when hydrogen is used as a fuel produced from renewable sources. Low-temperature fuel cells, including proton exchange membrane fuel cells, are taken into consideration for e-mobility spanning from low-medium to heavy-duty vehicles thanks to their high-power density. However, the high cost of cell components due to the highly corrosive acidic environment hindered their market-level penetration. Therefore, significant research efforts were dedicated to reducing the cost of cell components, mainly catalysts, membranes, air-loop, and the balance of the plant. Despite that, the cost reduction has been stagnant for the last few years and has not been able to achieve the United States Department of Energy ultimate cost target of 30 USD per kW to make it competitive with internal combustion engines. On the other hand, emerging anion exchange membrane fuel cells offer several advantages vs state-of-the-art proton exchange membrane fuel cells and make the e-mobility dream a reality. Owing to these advantages, anion exchange membrane fuel cells have shown promise to meet the US DOE cost target by implementing non-precious components to the cell stack. In this presentation, I will be addressing several aspects of low-temperature fuel cell development, from components to cell level. This talk will cover the fundamental concepts to the fabrication of fuel cells. I will highlight the key achievements and major challenges that need to be addressed in the near future.</p>		

A REPORT ON Low-temperature Fuel Cells for Electrochemical Propulsion: Fundamentals, Major Components, Cell Fabrication and Real-time Applications

A Faculty Development Program on “Low-temperature Fuel Cells for Electrochemical Propulsion: Fundamentals, Major Components, Cell Fabrication and Real-time Applications” was organized by the Teaching Learning Centre of Excellence (TLCE) and CO₂ Research and Green Technologies Centre, VIT Vellore on the 12th March 2025, at TT 707, VIT Vellore.

The resource person for the session was Dr. Ramesh Kumar Singh, Assistant Professor Sr. Grade II who was introduced by Director TLCE Dr. R. Thundil Karuppa Raj. In brief, Dr. Singh has almost 15 years of experience in the field of fuel cells. He has published several works on low-temperature fuel cells not only for the developing efficient catalyst materials but also showing their promise to device level. The lecture was witnessed the presence of Vice Chancellor Dr. V S Kanchana Bhaaskaran Madam. The TLCE team showcased the ~10 kW fuel cell stacked developed by VIT during the presentation. The talk covers the history, types, and basics of the fuel cells-particular focused on low-temperature fuel cells. During the talk, there was plenty of interactions on how to build our own stack starting from basic research to all the ways to fuel cell applications. The audience from various background ranging from Chemistry, Mechanical and PhD. students from Chemistry, CO₂ Research and Green Technologies Centre and across the Institute. In summary, this talk is very useful for the people for different backgrounds including Chemistry, Material Scientist, Chemical-, Mechanical- and Electrical-Engineers. All the audience was benefited from the fuel cell research starting from components to device fabrication and what we do further a team to enhance the research horizon and challenging issue in low-temperature fuel cell technology.

After his lecture, the faculty members, students interacted with him on fuel cell technology and its implementation in India as it is presently expensive compared to the existing internal combustion engine-based engine. They were pleased to connect fuel cell and its components knowledge with this lecture and excited on the fuel cell development on the practical level. Finally, the faculty coordinators gave a vote of thanks and appreciated the guest for such a lecture and ended the event.

Geotagged photos of the event with caption and date (at least 2 Nos)



1	Faculty Coordinators	<ol style="list-style-type: none"> 1. Dr.Krithika L B 2. Dr. Sujatha R
2	Enclosures (For Thon Activity)	<ul style="list-style-type: none"> • Invitation • Problem statements for Thon Activity • Evaluation rubrics • One Page Profile (for External Experts)
3	Industrial Collaboration Details (For Thon Activity)	<ol style="list-style-type: none"> 1. Dr.Suresh M Co-Founder & CEO NITInnov Technologies (P) Ltd., Chennai, India. 2. Dr. Vijay Anand Professor Grade 1, Department of Information Technology, School of Computer Science Engineering & Information Systems, VIT, Vellore.
4	(If Course specific) Course Code:	BITE307L
	Course Name:	Software Engineering
5	SDGs aligned to (Tick the suitable one)	SDG 1: No Poverty SDG 2: Zero hunger SDG 3: Good health and well-being SDG 4: Quality education SDG 6: Clean water and sanitation SDG 8: Decent work and economic growth SDG 13: Climate action
6	Expected number of Participants	112 (includes 109 students + 2 coordinators +1 internal judge)
7	Total No. of Days/Hours	24 hrs
8	Documents to be Submitted (Post Event)	<ul style="list-style-type: none"> • Invitation • Problem Statement • Mapped SDGs for the given problem statement. • Outcome of the event • Evaluation sheets • Attendance Sheet • Geo-tagged Photograph • Feedback Form • Winners List
9	Faculty In-charge to upload in IQAC Note: To upload the documents in IQAC within 15 days of completion of the event	1. Dr.Krithika L B



VIT[®]

Vellore Institute of Technology
(Deemed to be University under section 3 of UGC Act, 1956)

School of Computer Science Engineering and Information Systems
Department of Software & Systems Engineering
Winter Semester 2024-25

Cordially invites you for the

Proto-A-Thon

On

“Tech for Good: Building a Sustainable future through IT Solutions”

DATE : 08.03.25
TIME : 8 AM to 6 PM
VENUE : Homi Bhabha Gallery

SCHEDULE

Date & Time	Event
07-03-2025 4:00 pm to 8:00 pm	Start of Proto-A-Thon (Monitored Online)
08-03-2025 8:00 am to 4:00 pm	Prototype Working and Development(Offline) Homi Bhabha Gallery
08-03-2025 4:00 pm to 6.00 pm	Judging : 1. Dr.Suresh M (External) 2. Dr. Vijay Anand (Internal)

1. Dr. Sujatha R

2. Dr.Krithika L B

Faculty Coordinators

Dr. Neelu Khare

HoD – SSE

Dr. Daphne Lopez

Dean i/c,

Dr. Suresh M., Ph.D.,
suresh@nitinnovtech.com
Phone + 91 94434 69663

PROFESSIONAL SUMMARY

- 20+ years of experience in developing application using Python, NodeJS, C# combined with RDBMS and NoSQL DBs to design scalable and cost efficient solutions.
- Strong knowledge in Deep Learning, Data engineering, Data modeling, Data warehousing, Data analysis, ETL, BI reporting using AWS and Azure services.
- Knowledge in full Software Development Life Cycle, Machine Learning, Deep Learning techniques and Internet of Things (IoT).
- Handled server migrations collaborating with DBAs, IT Admins and Dev team.

EDUCATIONAL QUALIFICATION

- Doctor of Philosophy (Cloud Security) from Anna University (2009 – 2017).
- Master of Business Administrations from Periyar University (2005 – 2007).
- Master of Computer Applications from IGNOU (2001 – 2005).
- Diploma in Mechanical Engineering from VMKVSS Polytechnic College, Salem (1994 – 1997).

JOB EXPOSURE

- Exploring cost effective approach to improvise performance using Microsoft Azure, Amazon AWS and similar cloud platforms.
- Hands-on in designing databases based on the requirements and scale up the performance with query optimisation
- Converting monolithic applications into microservices and deploying it in the cloud infrastructure to develop scalable applications.
- Taking care of requirement analysis and developing PoCs using Deep learning algorithms to do image processing
- As Data Architect to handle the data warehousing, modelling to generate Business Intelligence reports.
- Designing data models using ML/DL algorithms and Hyperparameter tuning
- Analyse workflow and automate manual processes, taking complete responsibilities on non-functional requirements of the projects.

ON SITE EXPERIENCE

- Visited Portugal, Spain, Australia, Malaysia and USA to collate business requirements for the various clients' digital transformation process.

PROFESSIONAL EXPERIENCE

Company : **NITInnov Technologies (P) Ltd., Chennai.**
Position/Role : Co Founder & CEO
Period of employment : Jul 2023 - till date

Company : **Reinvision Labs (P) Ltd., Hyderabad.**
Position/Role : AI Consultant
Period of employment : Mar 2023 - Mar 2024

Company : **VMG Digital (P) Ltd., Chennai.**
Position/Role : Solutions Architect
Period of employment : Mar 2019 - Feb 2023

Company : **Crotus Technologies (P) Ltd., Chennai.**
Position/Role : Technical Architect & Delivery Lead
Period of employment : Oct 2013 – Mar 2019

Company : **FireStream Worldwide Inc., Chennai.**
Position/Role : Technical/Team Lead
Period of employment : Nov 2006 – Oct 2013

Company : **Zeta Cyber Solution (P) Limited, Chennai.**
Position : Software Developer
Period of employment : Jan 2006 – Nov 2006

Company : **VMRF Deemed University, Salem.**
Position : System Programmer-Network
Period of employment : Jun 1999 – Dec 2005

Proto-A-Thon - Solving for Sustainable Development

Are you passionate about creating a more sustainable world? Do you have innovative ideas that can address pressing global challenges? Then join us for "Solving for Sustainable Development," a dynamic Proto-a-thon designed to empower individuals like you to make a real difference.

You'll have the opportunity to team up with fellow innovators, designers, developers, sustainability experts, and other passionate individuals to tackle real-world sustainability challenges. Whether you're interested in clean energy, sustainable agriculture, responsible consumption, climate action, or any other area related to the SDGs, this Proto-a-thon offers a platform to bring your ideas to life.

- No poverty ([SDG 1](#))
- Zero hunger ([SDG 2](#))
- Good health and well-being ([SDG 3](#))
- Quality education ([SDG 4](#))
- Clean water and sanitation ([SDG 6](#))
- Decent work and economic growth ([SDG 8](#))
- Responsible consumption and production ([SDG 12](#))
- [Climate action](#) ([SDG 13](#))

Expected participants: 130

Rounds:

1. Day 1 (07/03/2025) – Filling the google form – Title and Team members.
<https://forms.gle/aAzu6m5ios1qF8PUA>
2. Day 2 (08/03/2025) 8:00 AM to 6:00 PM – Developing the prototype and Evaluation.

The proto should address the following key aspects:

- *Device Innovation*
- *Data Connectivity*
- *Real-time Data Analysis*
- *User-Friendly Interface*
- *Scalability*

Problem Statements

PROTO001. Smart Crop Rotation Optimization (SGD 1 & SDG 2)

Smart Crop Rotation Optimization is a software solution designed to help farmers maximize their yields and profits by recommending optimal crop rotation schedules. It aims to improve soil fertility, reduce pest pressure, minimize fertilizer use, and ultimately increase farm profitability while promoting sustainable agricultural practices.

Objective

The primary objective of this software is to provide farmers with data-driven insights to make informed decisions about crop rotation. This involves:

Output:

Recommended Crop Rotation Schedule: A detailed plan outlining the sequence of crops for a given field over a specified period (e.g., 3-5 years).

PROTO002. Precision Food Adulterant Detection with AI -SDG 3

This project aims to develop an AI-powered software solution for the rapid and precise detection of food adulterants.

Objective:

The primary objective of this project is to create a functional prototype of a software application capable of Capturing images of food samples using a standard camera and presenting the results of the analysis in a clear and concise report, including the probability of adulteration and, if possible, the identified adulterant.

Output:

The software prototype will consist of the following components a user-friendly interface, Image Processing Module will handle image preprocessing tasks and will extract relevant features from the processed images.

PROTO003. AI-Powered Personalized Medicine Platform – SDG 3

This platform aims to revolutionize healthcare by leveraging AI to deliver personalized medicine recommendations. It integrates diverse patient data, including genomic information, medical history, lifestyle factors, and real-time health data to provide tailored treatment plans, predict disease risk, and optimize drug selection.

Objective:

The primary objective for the proto-a-thon is to develop a functional prototype demonstrating the core functionalities of the platform, focusing on a specific use case.

Output :

The expected output of the proto-a-thon would be a working prototype that demonstrates the feasibility and potential of the platform.

PROTO004. Mental Health Support Platform for Women in High-Stress Careers – (SDG 3 & SDG 8)

This platform aims to provide accessible and tailored mental health support specifically for women working in high-stress careers.

Objective :

The primary objective of this proto-a-thon project is to develop a functional prototype Personalized Resource Recommendations based on the stress assessment, the platform will recommend relevant resources, such as articles, videos, mindfulness exercises, and coping strategies.

Output:

The primary output of the proto-a-thon will be a working prototype of the platform, which will include Functional Web/Mobile Application.

PROTO005. AI-Powered Waste Management System (SDG 12)

This project aims to develop an AI-powered waste management system that optimizes waste collection, sorting, and processing.

Objective:

The primary objective of this project is to create a more efficient and sustainable waste management system

Output:

The project will deliver Smart Bin Software and Image Recognition Module:

PROTO006. Revolutionizing Remote Patient Monitoring for Chronic Diseases: (SDG 3)

This project aims to develop a software solution for revolutionizing remote patient monitoring (RPM) for individuals with chronic diseases.

Objective:

The primary objective of this proto-a-thon project is to develop a functional software prototype demonstrating the core features of a RPM system.

Output:

The primary output of this proto-a-thon project will be a functional software prototype demonstrating the functionality of data acquisition, real-time monitoring, alert generation, data visualization, and user interfaces.

PROTO007. AquaInsights: Smart Water Resource Management (SDG 6)

Develop a platform that collects and analyzes data from various sources (e.g., water quality sensors, rainfall data, sanitation facility usage) to provide insights for better water resource management and sanitation planning.

- **Objective:** To create a system that enables real-time monitoring of water quality and sanitation infrastructure, predicts potential issues, and supports data-driven decision-making for resource allocation and intervention.
- **Output:** A web/mobile application that visualizes water quality data, sanitation facility usage, and predictive analytics. This could include dashboards, reports, and alerts for stakeholders.

PROTO008. JalSaathi: Connecting Communities for Clean Water (SDG 6)

Build a mobile app that empowers communities to report water and sanitation issues, access information about water quality and hygiene, and participate in local initiatives.

- **Objective:** To improve community engagement in water and sanitation management by providing a platform for two-way communication and information sharing.
- **Output:** A user-friendly mobile app with features for reporting issues (e.g., broken pipes, contaminated water), accessing educational resources (e.g., hygiene tips, water conservation), participating in surveys, and receiving notifications about relevant updates.

PROTO009. HydroGuard: Predictive Maintenance for Water Infrastructure (SDG 6)

Develop a system that uses machine learning to predict potential failures in water and sanitation infrastructure (e.g., pipe leaks, pump malfunctions) based on sensor data and historical maintenance records.

- **Objective:** To reduce downtime and improve the efficiency of water and sanitation infrastructure maintenance through predictive analytics.
- **Output:** A software system that integrates with existing sensor networks, processes data using machine learning algorithms, and generates alerts for potential failures.

• **PROTO010. AquaLearn: Gamified Water and Sanitation Education (SDG 3, SDG 4 & SDG 6)**

Create an interactive, gamified mobile app that educates users about water conservation, hygiene, and sanitation best practices.

- **Objective:** To improve awareness and promote positive behavior change related to water and sanitation through engaging educational content.
- **Output:** A mobile app with game-like elements that teaches users about important water and sanitation topics. The app could track user progress and provide personalized feedback.

PROTO011. WaterWise: Smart Irrigation and Water Management (SDG 2, SDG 6 & SDG 13)

Develop a system that optimizes water usage for irrigation by integrating weather data, soil moisture sensors, and plant requirements.

- **Objective:** To conserve water resources and improve agricultural productivity through smart irrigation practices.
- **Output:** A software platform that collects data from various sources, provides real-time irrigation recommendations, and allows users to control irrigation systems remotely.

PROTO012. Smart Energy Management System for Sustainable Living (SDG 7)

A software solution to optimize energy consumption in residential and commercial buildings, promoting the use of renewable energy sources and reducing energy costs.

Objective:

- Develop a user-friendly platform to monitor and control energy usage in real-time.

Output:

- A web and mobile application with intuitive dashboards and visualizations.

PROTO013. Carbon Footprint Tracker & Reducer (SDG 13)

A mobile and web application that allows individuals and/or organizations to track their carbon footprint based on various activities. The app provides personalized recommendations and resources to reduce their impact. Gamification elements can be incorporated to encourage engagement.

- **Objective:** To empower users with knowledge about their carbon footprint and provide actionable steps to minimize it, thereby contributing to climate change mitigation efforts.
- **Output (Software Focus):**
 - Integration with external APIs for data enrichment (e.g., energy consumption data, travel information).

PROTO014. EduTailor: Adaptive Learning for All (SDG 4)

A personalized learning platform that adapts to individual student's learning styles and pace. It leverages AI to analyze performance and recommend relevant content, exercises, and learning strategies.

- **Objective:** To create a software platform that delivers personalized educational content and tracks student progress, ultimately improving learning outcomes.
- **Output:** A functional prototype of the EduTailor platform, including user interfaces for students and educators, an AI-powered recommendation engine, and a progress tracking dashboard.

PROTO015. Learn & Play: Gamified Education (SDG 4)

A collection of interactive educational games designed to make learning engaging and fun. The games cover various subjects and age groups, incorporating game mechanics to motivate students.

- **Objective:** To develop a set of engaging educational games that enhances learning through interactive gameplay and provides real-time feedback.
- **Output:** Playable prototypes of several educational games, demonstrating core gameplay mechanics, educational content integration, and user progress tracking.

PROTO016. EduConnect: Streamlining Teacher Resources (SDG 4)

A platform that helps teachers manage educational resources, create lesson plans, and collaborate with other educators. It simplifies administrative tasks and provides access to a vast library of educational materials.

- **Objective:** To build a software system that improves teacher efficiency and facilitates resource sharing, ultimately enhancing the quality of instruction.
- **Output:** A working prototype of the EduConnect system, showcasing features like resource upload and organization, lesson plan creation tools, collaborative spaces, and a searchable database of educational materials.

PROTO017. AskEdu: Your AI Tutor (SDG 4)

An AI-powered tutoring system that provides personalized support to students. It can answer questions, explain concepts, and provide feedback on assignments, available 24/7.

- **Objective:** To develop an AI tutor that supplements traditional teaching methods, offering personalized assistance and improving student understanding.
- **Output:** A functional prototype of the AskEdu system, demonstrating natural language processing capabilities, knowledge base integration, and personalized feedback generation.

PROTO018. Smart Energy Optimizer (SDG 7)

A software solution that helps homeowners or businesses optimize their use of renewable energy sources (solar, wind, etc.) and reduce reliance on fossil fuels. The system can predict energy generation and consumption, and intelligently control appliances to maximize self-consumption and minimize grid dependence.

- **Objective:** To increase the adoption and effective utilization of renewable energy, contributing to a cleaner energy mix and reduced greenhouse gas emissions.
- **Output (Software Focus):**
 - Predictive algorithms for energy generation and consumption forecasting.

PROTO019. Sustainable Shopper Assistant (SDG 12)

A mobile app that helps consumers make more sustainable purchasing decisions. It could scan product barcodes to provide information on environmental impact, ethical sourcing, and availability of eco-friendly alternatives.

- **Objective:** To promote sustainable consumption patterns by providing consumers with readily accessible information and encouraging them to choose environmentally and socially responsible products.
- **Output (Software Focus):**
 - Mobile app with barcode scanning functionality.

PROTO020. Climate Data Visualizer (SDG 13)

A web-based platform that visualizes climate change data (temperature trends, sea level rise, extreme weather events, etc.) in an engaging and accessible way.

- **Objective:** To improve public understanding of climate change and its impacts through compelling data visualization, promoting informed decision-making and action.
- **Output (Software Focus):**
 - Potential for incorporating user-generated content or citizen science data.

Outcome of the Proto-A-Thon event

The **Proto-A-Thon** event, centered on web technologies, proved to be an enriching experience for students, fostering innovation and collaboration while addressing critical global challenges.

Comprehensive overview of the event's outcomes:

Event Structure

1. **Team Formation:** Students were divided into teams of up to four members, promoting teamwork and diverse skill sets.
2. **Problem Statement Selection:** This method not only added an element of excitement but also allowed students to engage with a variety of issues related to the **Sustainable Development Goals (SDGs)**.

Focus Areas

The problem statements were aligned with the following SDGs:

SDG 1: No Poverty

SDG 2: Zero hunger

SDG 3: Good health and well-being

SDG 4: Quality education

SDG 6: Clean water and sanitation

SDG 8: Decent work and economic growth

SDG 13: Climate action Technological Implementation

1. **Core Technologies:** Teams primarily utilized foundational web technologies:
 - **HTML** for structuring content.
 - **CSS** for styling and layout.
 - **JavaScript** for interactivity and dynamic content.
 - **PHP** and **MySQL** for server-side scripting and database management.
2. **Advanced Frameworks:** Many teams opted for modern frameworks to enhance their applications:
 - **Node.js** for server-side development, enabling efficient handling of asynchronous requests.
 - **AngularJS** and **React** for building dynamic user interfaces, allowing for a seamless user experience.

Evaluation Process

The projects were rigorously evaluated by a panel of industry expert and academic professionals. The evaluation criteria included:

- **Design Approach:** Originality of the solution and its approach to the problem.
- **Technical Execution:** Quality of the code, use of technologies, and overall functionality of the application.
- **Presentation:** Clarity and professionalism in presenting the project, including the ability to articulate the problem, solution, and technical details.

Notable Projects

Several standout projects emerged from the event, including:

- **Health Tracker App:** An application that allows users to monitor their health metrics and connect with local healthcare resources, promoting proactive health management.
- **E-Learning Platform:** A web-based platform that connects students with mentors and provides access to educational resources, aimed at enhancing learning opportunities for underprivileged communities.
- **Smart City Initiative:** A project that integrates various urban services into a single platform, enabling citizens to report issues, access public services, and engage in community planning.
- **Sustainable Community Engagement Tool:** An application designed to facilitate communication among residents about sustainability initiatives, encouraging participation in local environmental efforts.

Skill Development and Learning Outcomes

Participants not only enhanced their technical skills but also gained valuable experience in:

- **Team Collaboration:** Working effectively in teams, managing roles, and resolving conflicts.
- **Problem-Solving:** Developing critical thinking skills to address complex issues creatively.
- **Project Management:** Planning, executing, and presenting projects within a set timeframe.

Conclusion

The Proto-A-Thon was a remarkable success, showcasing the talent and creativity of students while emphasizing the importance of technology in achieving sustainable development. The event not only provided a platform for innovation but also inspired participants to think critically about their role in addressing global challenges.



GPS Map Camera

Homi Bhabha Gallery,SJT,VIT
X5C7+9GX, Vellore, Tamil Nadu 632014, India
Lat 12.970977°
Long 79.163865°
08/3/2025 10:46 AM GMT+05:00

Google



GPS Map Camera

Homibhabha gallery,SJT Tamil Nadu, India
X5C7+9GX, Vellore, Tamil Nadu 632014, India
Lat 12.970977°
Long 79.163865°
08/3/2025 05:38 PM GMT+05:00

Google

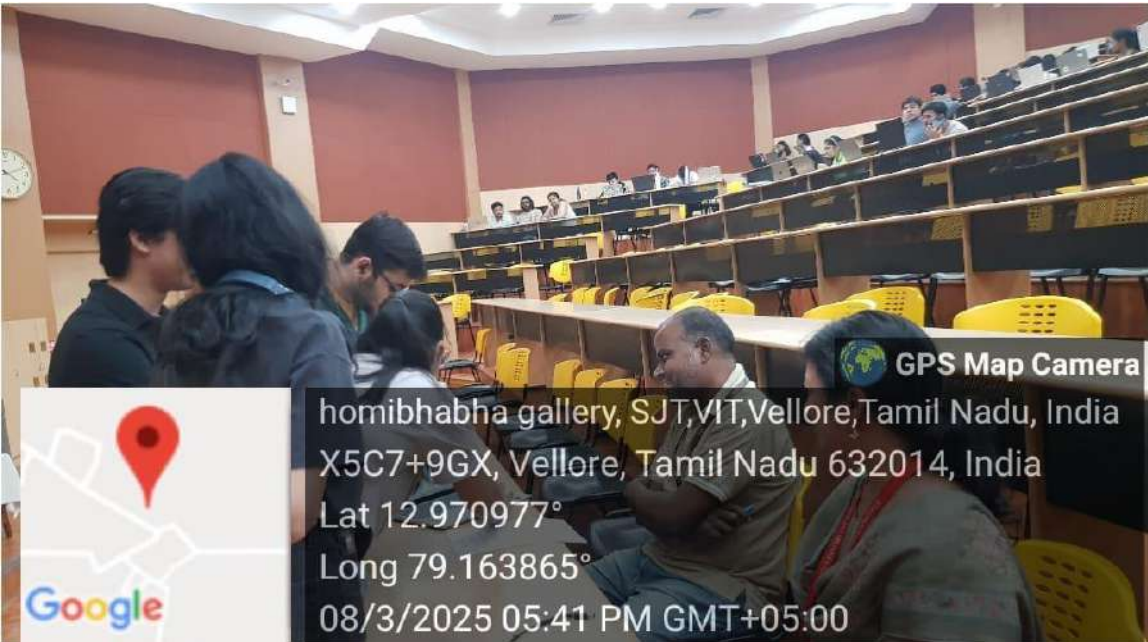

Proto-A-Thon

Language changes detected. Please restart Teams to see the change. Apply and restart

24:41:49

Chat 50 People Rate React View Apps More Camera Mic Share Leave

 KRITHIKA L.B.	 Rukshana N.	 Rangan Raju
 Suresh Madhesan (External)	 Abhinav Anand	 Vedant Gupta
 Abhishek Jain	 Madhuja K	 Siddharth Goutam Kumar

< 1/6 >

Type here to search

04:28 PM 08-03-2025

Proto-A-Thon

Language changes detected. Please restart Teams to see the change. Apply and restart

24:50:43

Pop out Chat People Rate React View Apps More Camera Mic Share Leave

Participants

kavya

In this meeting

- KJ Kavya Jain

Not in this meeting

- KA Kavya Alluru
- KP Kavya Pant
- KB Kavya B
- KP Kavya P
- KP Kavya Pandey
- KB Kavya Bhojwani

Windows taskbar: Type here to search, Proto-A-Thon, 04:35 PM 08-03-2025

Proto-A-Thon

Language changes detected. Please restart Teams to see the change. Apply and restart

25:02:31

Pop out Chat People Rate React View Apps More Camera Mic Share Leave

Participants

afham

In this meeting

- AA Afham Faiyaz Ahmad

Not in this meeting

- AD AFHAM DUNNUR
- AS Adham Sheik
- AB Adham Badri

Windows taskbar: Type here to search, EcoShop - Empowering Sustainable Decides, © 2025 EcoShop. All rights reserved. 04:45 PM 08-03-2025

VIT

 Vellore Institute of Technology
(Deemed to be University under section 3 of UGC Act, 1956)
School of Computer Science Engineering and Information Systems
Proto-A-Thon on
“Tech for Good: Building a Sustainable future through IT Solutions”

Date: 8-03-2025

Time:

FEEDBACK FORM FOR Proto-A-Thon

Your feedback is critical for the organizers to ensure if we are meeting your educational needs. We would appreciate if you could take a few minutes to share your opinions with us so that we can serve you better.

Please return this form to the organizer at the end of the event. Thank you.

Please rate the following on a five-point scale.

[5- Excellent; 4-Very Good; 3-Good; 2: Fair; 1: Poor]

- | | | | | | |
|---|-----|-----|---|---|---|
| 1. Did you like fun working in groups? | 5 | 4 ✓ | 3 | 2 | 1 |
| 2. Did you gain knowledge? | 5 ✓ | 4 | 3 | 2 | 1 |
| 3. Will this event improve your coding skills? | 5 ✓ | 4 | 3 | 2 | 1 |
| 4. Did you understand the scenarios given in the event? | 5 | 4 ✓ | 3 | 2 | 1 |
| 5. Was the event well organised? | 5 | 4 ✓ | 3 | 2 | 1 |

What did you most appreciate/ enjoy/ think was best about this event?

Grouped coding.

Please provide suggestions for improvement?

THANK YOU!!!



VIT

Vellore Institute of Technology

(Deemed to be University under section 3 of UGC Act, 1956)

School of Computer Science Engineering and Information Systems

Department of Software and Systems Engineering

Winter Semester 2024-25

Proto-A-Thon - Tech for Good: Building a Sustainable future through IT Solutions

Evaluation Sheet

Venue: Homi Bhabha Gallery Date: 08 March - 2023 Timings: 08:00 am - 06:00 pm

Topic Chosen: Learn and Play: Gamified Learning

Team Name: Alpha

Team Info: 1

S.No	Register Number	Name	Signature
1. (TL)	23BIT0134	Kashish Agarwal	
2. (TM)	23BIT0149	Pratyaksh Savena	
3. (TM)	23BIT0182	Manan Kothari	
4. (TM)	23BIT0218	Manya Kulkarni	

Mark Distribution

Components	Marks Attained	Remarks
Design Approach (20 M)	18	
Implementation (20 M)	18	
Result (10 M)	9	
Total (50 M)	45	

Evaluator 1 Name & Signature

Dr.Suresh M
Evaluator 2 Name & Signature

Winners List !!!

Selected Teams are 1, 8, 9, 11, 13, 19, 23, 32



VIT[®]
Vellore Institute of Technology
(Deemed to be University under section 3 of UGC Act, 1956)



ENERGY CONSERVATION WEEK (2024)

(14-18th December 2024)

In Commemoration of the 40th year celebrations of VIT

Organized By
**SCHOOL OF ELECTRICAL
ENGINEERING VELLORE
INSTITUTE OF TECHNOLOGY
VELLORE 632 014**



SCHOOL OF ELECTRICAL ENGINEERING

Day 1 – Inauguration and Energy Audit Event

National Energy Conservation Day is celebrated on December 14 to raise awareness on the possible ways to save energy resources. To commemorate this and also the 40th year celebrations of Vellore Institute of Technology, School of Electrical Engineering of Vellore Institute of Technology, Vellore organized an one-week awareness program on Energy Conservation from 14th December to 18th December 2024.

The inauguration of the energy conservation week was held on 14th December 2024. Dr. Ramesh Darla B, Assistant General Manager, India South Asia Middle East and Africa, R &D, Panasonic, Bangalore inaugurated the event and delivered the awareness talk on energy conservation practices. Dr. V S Kanchana Bhaaskaran Vice Chancellor, Vellore Institute of Technology presided over the function and insisted the need of environmental conservation with aid of product development and innovations.

Various events like eco fashion contest, poster presentation, animation, short film, slow cycling Nukkad Natak, walkathon and events exclusive for school students are proposed in the thematic areas of energy conservation to enhance the skills of students.

A national level energy auditing competition is held on 14th December 2024. Students from various parts of the country registered for this event. The need for energy auditing serves a better propose in economic analysis, power quality improvement, cost saving and energy management across residential and industrial users. The active participation of students and faculty in large numbers resulted in the appropriate dissemination of energy and environment conservation practices in protecting our planet earth. Based on the presentation of the audit report, the first three prizes are begged by Alagappa Chettiar Government College of Engineering and Technology, Karaikudi, Reva University, Bangalore and Amrita University, Coimbatore. Cash prizes along with certificates are given to the prize winners.



VIT
Vellore Institute of Technology
(Deemed to be University under section 3 of UGC Act, 1956)

SCHOOL OF ELECTRICAL ENGINEERING

Day 2: Drawing, Quiz and Project Display

As part of the Energy Conservation Week celebrations from 14th to 18th December 2024, School of Electrical Engineering hosted a series of engaging competitions for school students of classes LKG to 12th standard on 15th December. The Drawing, Quiz, and Project Display competitions aimed to raise awareness about energy conservation and inspire young minds to contribute to a sustainable future.

Drawing Competition

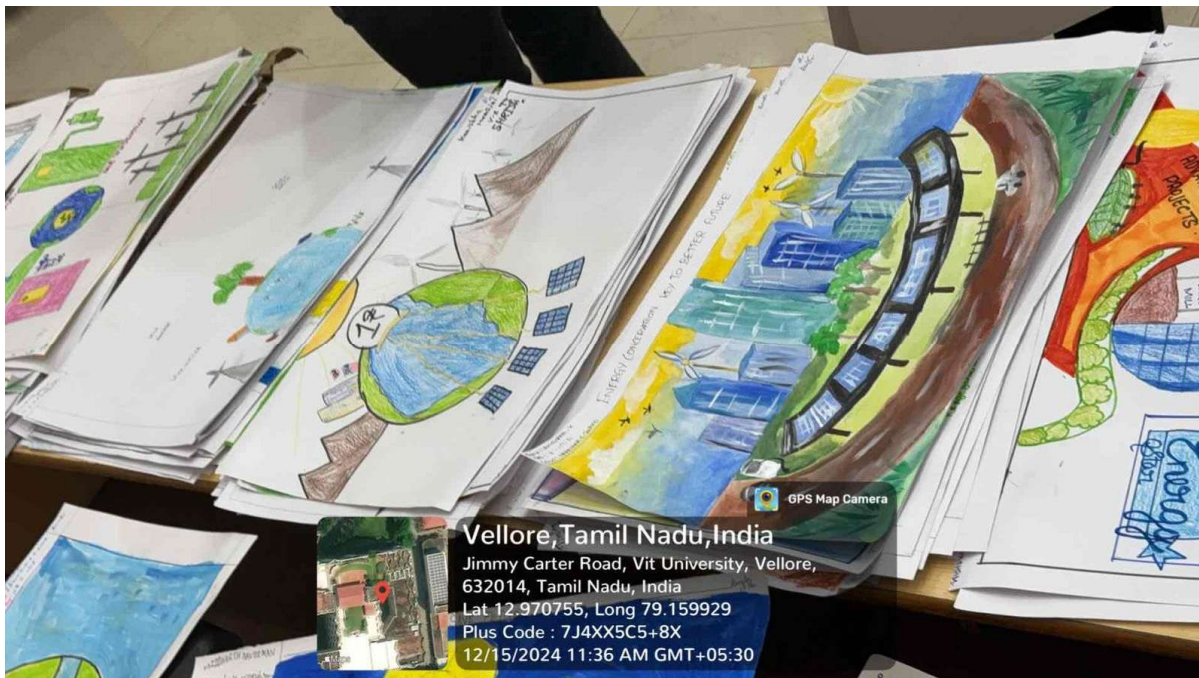

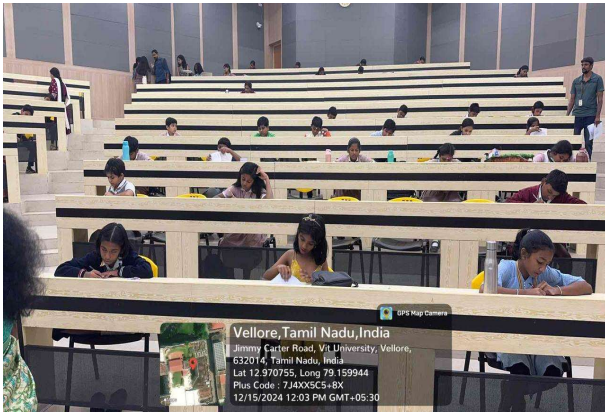

The Drawing Competition encouraged students to express their thoughts on energy conservation through art. There were 7 categories, students used crayons, colored pencils, watercolors, and digital tools to create vivid and impactful artwork. Entries were judged on creativity, relevance to the theme, and artistic technique. Over 330 students participated, and contributed vibrant and thought-provoking artwork.

Quiz Competition



The Quiz Competition focused on enhancing students' knowledge of energy resources, conservation techniques, and related science concepts. Separate quiz sessions were conducted oral quiz for classes LKG,UKG,1st and 2nd standard and written quiz for 3-4,5-6,7-8,9-10 and 11-12, The competition created awareness of energy conservation practices and global energy challenges.

Project Display Competition



The Project Display Competition gave students an opportunity to present innovative solutions to energy-related challenges. Students from Classes LKG-12th standard participated in groups or individually. Projects included models, prototypes, and presentations that demonstrated innovative thinking and problem-solving skills.

Judges praised the originality and feasibility of the projects. Projects like solar-powered devices, energy-efficient building models, and waste-to-energy concepts stood out. The exhibition attracted attention from both students and faculty, fostering meaningful discussions on sustainability.

Conclusion

The competitions were a resounding success, inspiring creativity, fostering intellectual growth, and encouraging innovation among participants. The winners were felicitated with certificates and prizes, while all participants received appreciation for their efforts.





VIT[®]
Vellore Institute of Technology
(Deemed to be University under section 3 of UGC Act, 1956)

SCHOOL OF ELECTRICAL ENGINEERING

Day 3: Poster Presentation, Nukkad Natak and Slow Cycling

Poster Presentation:

A Poster Presentation of Energy Conservation Week showcases research, projects, or initiatives focused on energy-saving practices and technologies. It involves creating a visual display summarizing the key aspects of the work and presenting it to attendees for discussion and feedback. It's an engaging way to share insights and promote sustainable energy practices.

The posters were presented in the Greenos pass way in the full display of all students.



Nukkad Natak:

A Nukkad Natak for Energy Conservation Week is a street play performed to raise awareness about the importance of saving energy. It creatively engages the audience with dramatic and impactful storytelling, highlighting energy-saving practices and the benefits of sustainable living in an entertaining and educational manner.



Slow cycle race:

A slow cycling race during Energy Conservation Week is an event where participants compete to ride their bicycles as slowly as possible without losing balance. It promotes energy efficiency and sustainability in a fun and engaging way, encouraging people to think about

how they can conserve energy in their daily lives.

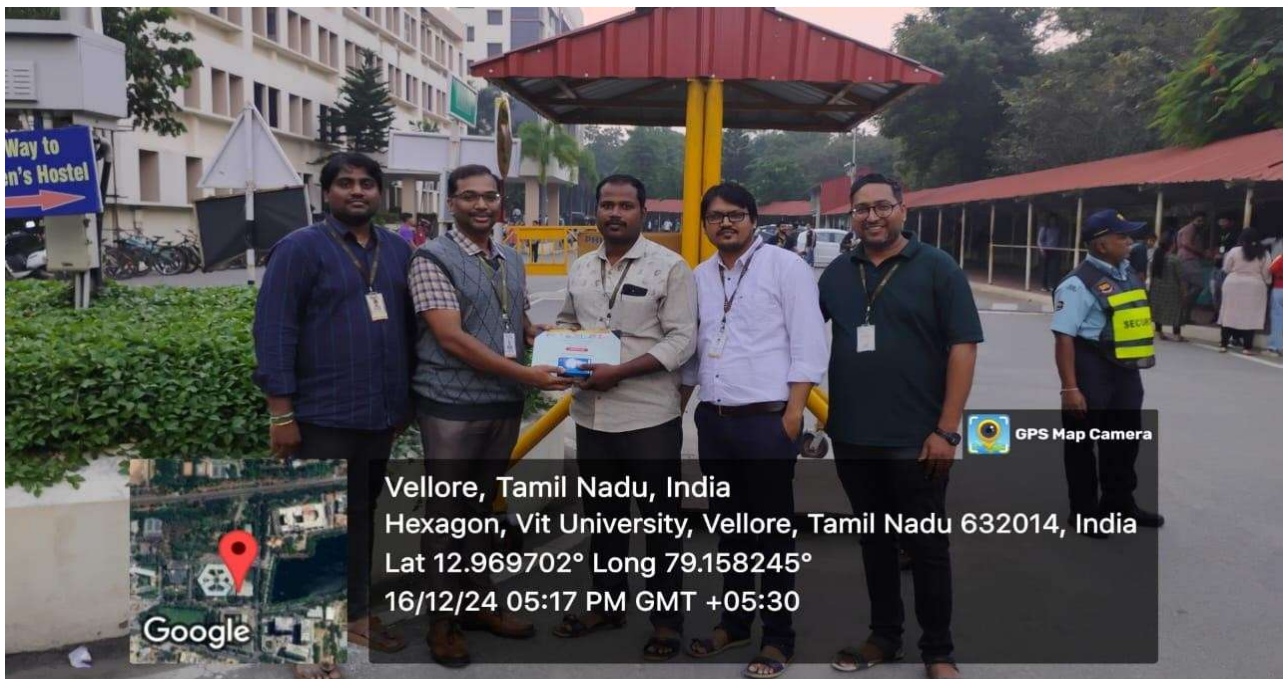



SCHOOL OF ELECTRICAL ENGINEERING

Day 4: Eco-Fashion Event

The Eco-Fashion event, held on 17/12/2024 during Energy Conservation Week, was a remarkable showcase of innovation and sustainability. Organized to promote eco-friendly practices in the fashion industry, the event featured a variety of ideas related to sustainable fashion, which refers to the design, production, and consumption of clothing, accessories, and footwear that aim to minimize their environmental impact and promote ethical practices.

Further, a panel discussion with experts on sustainable fashion trends was organized. Attendees were inspired by the creative ideas made from recycled and organic materials, demonstrating that fashion and environmental consciousness can go hand-in-hand. The event successfully raised awareness about the importance of energy conservation and sustainable practices, leaving a lasting impact on all participants.







VIT[®]
Vellore Institute of Technology
(Deemed to be University under section 3 of UGC Act, 1956)

SCHOOL OF ELECTRICAL ENGINEERING

Day 5: Animation and Short film competition

The Animation and Short film competition During ECW-2024, held on 18/12/2024 during Energy Conservation Week, was a remarkable showcase of creativity, innovation and sustainability. Organized to promote eco-friendly practices through Animation and Short film, the event featured a variety of ideas related to the awareness of energy conservation and beyond, which refers to the environmental concerns. The event successfully raised awareness about the importance of energy conservation and sustainable practices, leaving a lasting impact on all participants.

The active participation of students and faculties resulted in the appropriate dissemination of energy and environment conservation practices in protecting our planet earth. Based on the screening of short films and animation videos, jury members picked the winners and prizes along with certificates were given to the prize winners.

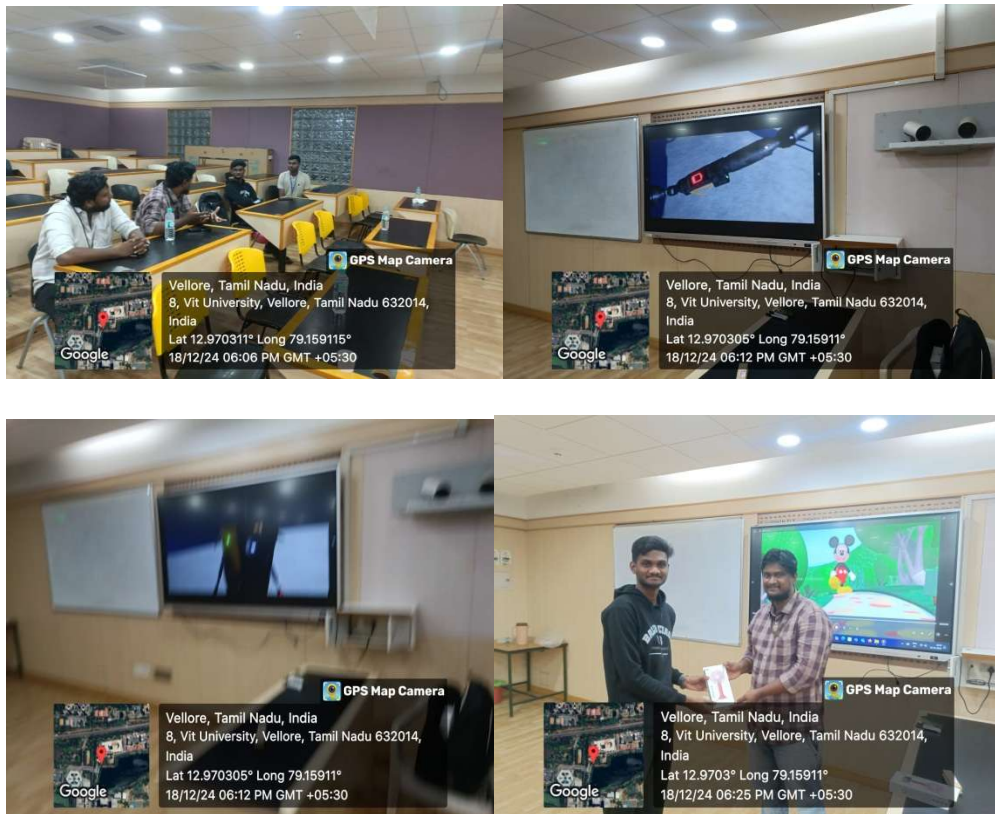



Sample Certificate

School of Electrical Engineering (SELECT)
Energy Conservation Week
14-18 December 2024

CERTIFICATE

This Certificate is Proudly Presented to

For Securing First Place / Second Place/ Third Place/ Participation in

Energy Conservation Week in _____

event held at Vellore Institute of Technology, Vellore.

Coordinator
ECW-2024

Dean
SELECT

Name and the contact number details of the student volunteers

S.No.	Register No.	Name of the Student Volunteers	Phone No.
1	23BEI0014	Aditya Kale	7517335119
2	23BEE0099	Rachneet Kaur	7503660140
3	23BEI0018	Kowsik N	9384244423
4	24BEE0167	Shreyansh Gupta	9450769020
5	24BEE0190	Srijan Sankar Singh	9319549716
6	24BEE0142	Samridhi Chandra	7307962274
7	23BEI0034	Vignesh N	9791226718
8	23BEE0071	Hannah Ajish	9321644832
9	24BEE001	Param Jathin Kumar	9106835913
10	24BEE0159	Bibek Sundaray	7846945106

Conclusion

The energy conservation week was a rousing success with the participation of faculties, staff, students, and participants from various schools and colleges. The events were interesting, challenging and a fun way to reaffirm our connection with nature. The participants got many ideas and insights about energy conservation strategies in these packed five-day celebrations.



VIT
Vellore Institute of Technology
(Deemed to be University under section 3 of UGC Act, 1956)



Centre for Nanotechnology Research
Vellore Institute of Technology, Vellore
in association with
ECS IITM Student Chapter &
AMETEK Princeton Applied Research, Solartron Analytical

Interactive Workshop on Electrochemical Technologies:
Emphasizing Batteries, Supercapacitors, and Fuel cells

December 5-6, 2024



Prof. Kothandaraman R
IIT Madras



Dr. Raman Vedarajan
ARCI, Chennai



Dr. Ganesh V
CSIR-CECRI, Karaikudi



Dr. Sunandan Sarkar
NIT Trichy

Workshop

Lectures, interactive sessions, & hands-on training:

- Basics of Electrochemistry
- Batteries
- Supercapacitors
- Fuel cells

Limited Seats Only

Last date for registration: Nov 25, 2024

The registration fee includes a registration kit, lunch, refreshments and a participation certificate

Register Now

Registration Fee:
Rs. 1000



Contact **Dr. George Jacob** Phone: +91 9994882510; Email : georgejacob@vit.ac.in
Dr. Andrews Nirmala Grace ; Email : director.cnr@vit.ac.in

Accommodation : Accommodation can be provided to external participants in the hostels (dormitory) based on request (Rs. 500+GST/day)



Topics & Speakers

Lecture 01

PROF. KOTHANDARAMAN R

Moles vs. charge capacity, rate of reaction vs. current density, Gibb's free energy vs. potential, Spontaneous vs. Galvanic cells, Non-spontaneous vs. Electrolytic cells, Activation energy vs. Overpotential, Use of Nernst eqn. to explain charge discharge, 2/3 electrode setup, Ideally polarizable/ non-polarizable electrodes, Reference electrodes, Diffusion/Migration, Mass transfer limited currents

Lecture 02

DR. RAMAN VEDARAJAN

Thermodynamics and Kinetic factors affecting performance, Electrochemical characterization in material selection, Challenges with durability and longevity, Emerging trends in Fuel cell technologies, Bottleneck in commercialization.

Lecture 03

DR GANESH V

Basic concepts of voltammetry, Linear Sweep Voltammetry (LSV), Cyclic Voltammetry (CV), Pulse Techniques - Theory, Need & Importance, Significance of scan rate and its effect on voltammogram, Aqueous and Non-aqueous electrolytes, Studies on supercapacitors and Battery, Measurement of capacitance / capacity from CV, Differentiation of EDLC and Pseudocapacitor, Practical aspects of voltammetry, Interpretation of results and calculation of parameters from CV

Lecture 04

DR. SUNANDAN SARKAR

Introduction to Quantum Dots, Modeling and Functionalization of QDs, Simulation Methods, Electronic Structure of QDs, Charge Transfer Dynamics at QDs Interfaces, Outcome

Interactive Workshop on Electrochemical Technologies: Emphasizing Batteries, Supercapacitors, and Fuel cells

December 5-6, 2024, at Centre for Nanotechnology Research, VIT Vellore.

Day 1 – Dec 05, 2024

Time	Activity
8:30 AM – 9.15 AM	Registration
9.15 AM – 9.30 AM	Opening Remarks, Welcome talk by Dr. Nirmala Grace, Director
9.30 AM – 11:00 AM (Session 1)	Dr. Kothandaraman.R <i>Professor – Department of Chemistry , IIT Chennai</i> Electrochemistry Essentials for Batteries
11.00 AM – 11.15 am	Q/A
11.15 AM - 11.45 PM	Refreshment Break
11.45 AM – 1.15 PM (Session 2)	Dr.Raman Vedarajan <i>Senior Scientist – Centre for Fuel Cell Technology, ARCI, IIT Madras Research Park, Chennai</i> Fuel cell fundamentals to applications
1:15 PM – 2.15 PM	Lunch
2.15 PM – 3.15 PM (Session 3)	Dr. Kothandaraman.R <i>Professor – Department of Chemistry , IIT Chennai</i> Electrochemical Impedance spectroscopy on Batteries
3.15 PM– 3.30 PM	Q/A
3.30 PM – 3.45 PM	Refreshment Break
3.45 PM – 6.00 PM	Practical Session – 2 Experiments

Day 2 – Dec 06, 2024

Time	Activity
9.00 AM – 9.15 AM	Opening Remarks
9.15 AM – 10.45 AM (Session 1)	Dr.V Ganesh <i>Senior Principal Scientist – CSIR – CECRI</i> Voltametric Techniques: Theory, Concepts, Interpretation and Applications in Energy Storage Devices
10.45 AM – 11.15 AM	Refreshment Break
11.15 AM – 1.00 PM	Practical session - 2 Experiments
1.00 PM - 2.00 PM	Lunch
2.00 PM - 3.30 PM (Session 2)	Dr. Sunandan Sarkar <i>Professor – Department of Chemistry, NIT Trichy</i> Computational Investigation of Charge Transfer Dynamics at CdSe Quantum Dots Interfaces
3.30 PM-3.45 PM	Refreshment Break
3.45 PM – 5.30 PM	Practical session - 2 Experiments
5.30 PM – 6.00 PM	Wrap up & Networking session

Interactive Hands-on Experiments:

Cyclic Voltammetry, Electrochemical Impedance Spectroscopy, Reference Electrode making, Fuel Cell, Galvanostatic Charge Discharge, Electrochromism.



Workshop Title: Interactive Workshop on Electrochemical Technologies: Emphasizing Batteries, Supercapacitors, and Fuel Cells

Date: December 5-6, 2024

Location: Kamaraj Auditorium, VIT, Vellore, Tamil Nadu, India

Organized by: Dr A Nirmala Grace, Dr George Jacob, Centre for Nanotechnology Research

Industry Sponsor: AMETEK Princeton Applied Research, Solartron Analytical

Lab Associates: ECS IITM Student Chapter

Speakers:

Prof. Kothandaraman R, IIT Madras

Dr. Raman Vedarajan, ARCI, Chennai

Dr. Ganesh V, CSIR-CECRI, Karaikudi

Dr. Sunandan Sarkar, NIT Trichy

The "Interactive Workshop on Electrochemical Technologies: Emphasizing Batteries, Supercapacitors, and Fuel Cells" was successfully conducted on December 5-6, 2024, at the Centre for Nanotechnology Research, VIT, Vellore, Tamil Nadu, India. The workshop brought together 44 participants, including faculties, researchers, and students, to explore the latest advancements, challenges, and future directions in key electrochemical energy storage and conversion systems. Through a blend of expert presentations, interactive discussions, and a hands-on demonstration, the workshop significantly enhanced participants' understanding of these critical technologies, fostered networking, and identified potential areas for collaborative

research and development. Key outcomes included a shared understanding of interdisciplinary challenges and a roadmap for sustainable energy innovation.

Session 1: Fundamentals of Electrochemistry

- **Presentations:** An introductory overview of electrochemical principles, including electrode kinetics, electrolyte properties, and charge transfer mechanisms.
- **Key Discussions:** Clarification on basic concepts, the importance of material properties in electrochemical performance, and common misconceptions. Participants engaged in a lively Q&A session regarding reaction pathways and efficiency.

Session 2: Batteries - Advancements & Challenges

- **Presentations:** Focused on Lithium-ion battery technology, next-generation battery chemistries (e.g., solid-state, Sodium-ion, Zinc-air), energy density, power density, cycle life, and safety aspects. Supply chain challenges and raw material sourcing were also discussed.
- **Key Insights:** The critical balance between energy density and safety; the potential of solid-state batteries to revolutionize EV and grid storage; and the need for sustainable material sourcing and recycling strategies.

Session 3: Supercapacitors - Rapid Power Solutions

- **Presentations:** Explored the unique characteristics of supercapacitors, including their high power density, rapid charge/discharge capabilities, and long cycle life. Discussions included various electrode materials (carbon-based, conducting polymers, metal oxides) and hybrid supercapacitors.
- **Key Findings:** Supercapacitors are ideal for applications requiring quick bursts of power (e.g., regenerative braking, rapid charging), often complementing batteries in hybrid systems. The focus was on improving energy density without compromising power.

Session 4: Fuel Cells - Sustainable Energy Conversion

- **Presentations:** Covered different types of fuel cells (PEMFC, SOFC), their operating principles, and applications in transportation, stationary power, and portable devices. Emphasis was placed on hydrogen production (green hydrogen), storage, and infrastructure challenges.
- **Key Learnings:** The pivotal role of catalysts in fuel cell efficiency; the opportunities and hurdles in establishing a hydrogen economy; and the ongoing research into more durable and cost-effective materials.

Interactive Demonstration

- **Activity:** Participants observed a live demonstration of a small-scale PEM fuel cell setup, illustrating the conversion of hydrogen and oxygen into electricity. This included real-time data monitoring of voltage, current, and power output. Additionally, a station demonstrated basic battery cycle testing and capacity measurement.

- **Impact:** This hands-on experience provided a practical understanding of the theoretical concepts discussed earlier, allowing participants to visualize the processes and interact with the equipment.

The "Interactive Workshop on Electrochemical Technologies: Emphasizing Batteries, Supercapacitors, and Fuel Cells" was a resounding success, effectively bringing together a vibrant community to collectively advance the understanding and development of crucial energy technologies. The insights gained, discussions fostered, and connections made during the workshop will undoubtedly contribute to accelerating innovation in sustainable energy solutions, paving the way for a greener future.



VIT[®]
Vellore Institute of Technology
(Deemed to be University under section 3 of UGC Act, 1956)

School of Electrical Engineering

5- Days Faculty Development Program Details

Event type	Faculty Development Program		
Title of the event	DESIGN AND DEVELOPMENT OF MICRO/SMART GRID INTENDED FOR SMART CITY DEVELOPMENT AND ENHANCING E-MOBILITY		
Date (From – To)	18-11-2024 to 23-11-2024		
Time	10:00 AM to 5:30 PM		
Venue	TT 311		
No. of Participants	43		
Coordinator(s)	Emp. ID.	Faculty Name	Department
	16177	Dr. Sonam Shrivastava	C&A
	19693	Dr. Albert Alexander S	EPE
Resource Person Name	Schedule Attached		
Designation	Schedule Attached		
Organization Details	Schedule Attached		
Place	Schedule Attached		
E-mail	Schedule Attached		
Mobile no.	Schedule Attached		

Signature of the Coordinator

Signature of the Dean

Dean
School of Electrical Engineering (SELECT)
Vellore Institute of Technology (VIT)
(Deemed to be University under section 3 of UGC Act, 1956)
Vellore – 632 014, Tamil Nadu, India

Schedule of BASIC FDP

FDP Application Number: 1715097932

Title of the FDP: DESIGN AND DEVELOPMENT OF MICRO/SMART GRID INTENDED FOR SMART CITY DEVELOPMENT AND ENHANCING E-MOBILITY

FDP Start Date: 18.11.2024

FDP End Date: 23.11.2024

Day 1	Day 2	Day 3	Day 4	Day 5	Day 6
9:00 – 9:30 Inauguration					
9:30 – 12:00 Session 1	9:30 – 12:00 Session 3	9:30 – 12:00 Session 5	9:30 – 12:00 Session 7	9:00 – 1:00 Industrial visit	9:30 – 12:00 Session 10
<ol style="list-style-type: none"> Name of the Expert: Dr.S. Kumaravel Designation: Associate Professor Organization: National Institute of Technology, Calicut Experience in Years: 18 years Topic to be taught: Development of a Nano-grid structure for Electric Vehicle Application 	<ol style="list-style-type: none"> Name of the Expert: Dr. Vijayakumar K Designation: Associate Professor Organization: Indian Institute of Information Technology, Design and Management, Kancheepuram Experience in Years: 12 Topic to be taught: Performance enhancement of battery energy storage in smart/micro grid 	<ol style="list-style-type: none"> Name of the Expert: Dr.J.Balamurugan Designation: Senior Manager Organization: Tamil Nadu Energy Development Agency (TEDA), Government of Tamil Nadu, Chennai Experience in Years: 18 Topic to be taught: Hybrid energy systems for sustainable smart city 	<ol style="list-style-type: none"> Name of the Expert: Dr.S.Senthil Kumar Designation: Professor Organization: National Institute of Technology, Trichy Experience in Years: 25 Topic to be taught: Smart grid design for EV applications 	<ol style="list-style-type: none"> Name of the Organization: Thiruvalam Substation Complete address with pin code: Thiruvalam Substation, Thiruvalam Industry Type: Substation Area of specification: Grid connected system, Protection and Switchgear 	<ol style="list-style-type: none"> Name of the Expert: Dr.S.N.Deepa Designation: Associate Professor Organization: National Institute of Technology, Calicut Experience in Years: 20 Topic to be taught: Artificial Intelligent methods to enhance the performance of smart/microgrid
12:00 – 1:00 Article Discussion	12:00 – 1:00 Article Discussion	12:00 – 1:00 Article Discussion	12:00 – 1:00 Article Discussion		12:00 – 1:00 Article Summary
<ol style="list-style-type: none"> Title of the Research Paper: Machine Learning based Smart Intrusion and Fault Identification (SIFI) in Inverter based Cyber-Physical Microgrids Name of the journal: Expert Systems with Applications Year of Publication: 2024 	<ol style="list-style-type: none"> Title of the Research Paper: Inner Resonance and Outer Current Based Control Strategy for Inductive Power Transfer System Used in Wireless Charging for Electric Vehicles Name of the journal: IET Electrical Systems in Transportation Year of Publication: 2024 	<ol style="list-style-type: none"> Title of the Research Paper: Design of a modular converter in hybrid EV charging station with efficient energy management system Name of the journal: Electrical Engineering Year of Publication: 2024 	<ol style="list-style-type: none"> Title of the Research Paper: Analysis of Isolated Phase Windings and Permanent Magnet Assists High Energy Efficient Hybrid-Reluctance (HR) Motor for Electric Vehicle Name of the journal: IET Electrical Systems in Transportation Year of Publication: 2023 		
1:00 – 2:00 Lunch	1:00 – 2:00 Lunch	1:00 – 2:00 Lunch	1:00 – 2:00 Lunch	1:00 – 2:00 Lunch	1:00 – 2:00 Lunch
2:00 – 4:30 Session 2	2:00 – 4:30 Session 4	2:00 – 4:30 Session 6	2:00 – 4:30 Session 8	2:00 – 4:30 Session 9	2:00 – 4:00 MCQ & Reflection Journal
<ol style="list-style-type: none"> Name of the Expert: Dr.L.Ashok Kumar Designation: Professor Organization: PSG College of Technology, Coimbatore Experience in Years: 22 Topic to be taught: Smart City Energy Planning: Integrating Data and Tools 	<ol style="list-style-type: none"> Name of the Expert: Dr.C. Christopher Asir Rajan Designation: Professor and Head Organization: Pondicherry Technological University, Pondicherry Experience in Years: 20 Topic to be taught: Power System Planning and Control for Smart City 	<ol style="list-style-type: none"> Name of the Expert: Dr.Bidyadhar Subudhi Designation: Professor Organization: National Institute of Technology, Warangal Experience in Years: 24 Topic to be taught: Power quality improvement techniques for smart/micro grid 	<ol style="list-style-type: none"> Name of the Expert: Dr.S.Albert Alexander Designation: Associate Professor Grade 2 Organization: Vellore Institute of Technology, Vellore Experience in Years: 17 Topic to be taught: Design of fault tolerant converters for EV applications in smart grid environment 	<ol style="list-style-type: none"> Name of the Expert: Dr.Mathew M. Noel Designation: Professor and Dean Organization: Vellore Institute of Technology, Vellore Experience in Years: 21 Topic to be taught: Research Methodology 	
4:30 – 5:30 Hands on training /Labs	4:30 – 5:30 Hands on training /Labs	4:30 – 5:30 Hands on training /Labs	4:30 – 5:30 Hands on training /Labs	4:30 – 5:30 Hands on training /Labs	4:00 – 5:00 Valedictory Session
Smart Grid Lab	Electric Mobility Lab	Micro Grid Lab	Converter design Lab	Solar PV Lab	

OBJECTIVES

Tomorrow's digital cities will be the product of today's dreams. Important elements in the creation of smart cities are the development of cohesive open telecommunication and software architecture, which will underpin the citizen-centric applications. These applications will also be applied in areas of national interest and social need, such as E-Health, Smart Energy and E-Education. The building blocks upon which smart cities will be created include smart and renewable energy; next-generation networks; smart buildings; smart transport and smart governance. To meet the goals of smart city in supporting a sustainable high-quality lifestyle for citizens, smart city certainly needs a smart grid. In this objective, this FDP intends to address the various renewable energy and smart grid technologies support in transforming the present cities to smart cities with aid of power electronics towards enhancing e-mobility.

CONTENT OF FDP TO BE COVERED

- Session 1:** Development of a nano-grid structure for electric vehicle application
 - Session 2:** Smart city energy planning: Integrating data and tools
 - Session 3:** Performance enhancement of battery energy storage in smart/micro grid
 - Session 4:** Power system planning and control for smart city
 - Session 5:** Hybrid energy systems for sustainable smart city
 - Session 6:** Power quality improvement techniques for smart/micro grid
 - Session 7:** Smart grid design for EV applications
 - Session 8:** Design of fault tolerant converters for EV applications in smart grid environment
 - Session 9:** Research Methodology
 - Session 10:** Artificial Intelligence methods to enhance the performance of smart/microgrid
- Industrial visit, Article discussions and Innovative Teaching practices



TARGET GROUP & MODE

Target Group: Assistant Professors/ Associate Professors/ Ph.D. scholars/ PG students/ Industry professionals

Mode: offline – face to face

TRAVELLING ALLOWENCE

External participants (traveling more than 20 km one side to attend the FDPs) who attend at least 90% of the sessions shall be reimbursed with the cost of traveling.

REGISTRATION DETAILS

Registration is free and it is limited to **50** participants. Applications will be selected on first-come-first serve basis.

HOW TO APPLY?

For registration, use the following link:

<https://atalacademy.aicte-india.org/login>

Last date for registration: **05 November 2024**

CONTACT DETAILS

Dr.S.Albert Alexander Ph.D., PDF(USA), SMIEEE.,
UGC Raman Research Fellow
Department of Energy and Power Electronics
School of Electrical Engineering
Vellore Institute of Technology
Vellore 632 014, Tamil Nadu.
Contact Mobile – 9865931597
E-mail: albert.alexander@vit.ac.in
Website: www.vit.ac.in



RESOURCE PERSONS



Dr.S.KUMARAVEL
National Institute of Technology
Calicut



Dr.L.ASHOK KUMAR
Principal
Thiagarajar College of Engineering
Madurai



Dr.K.VIJAYAKUMAR
Indian Institute of Information Technology
Design & Manufacturing, Kancheepuram



Dr.C.CHRISTOBER ASIR RAJAN
Puducherry Technological University
Puducherry



Dr.J.BALAMURUGAN
TEDA, Government of Tamil Nadu
Chennai



Dr. BIDYADHAR SUBUDHI
Director, National Institute of Technology
Warangal



Dr.S.SENTHIL KUMAR
National Institute of Technology
Trichy



Dr.MATHEW M NOEL
Dean, School of Electrical Engineering
Vellore Institute of Technology



Dr.S.N.DEEPA
National Institute of Technology
Calicut

Organizing Committee

Chief Patron

Dr.G.Viswanathan

Honorable Chancellor

Patrons

Shri Sankar Viswanathan, Vice President

Dr.Sekar Viswanathan, Vice President

Dr.G.V.Selvam, Vice President

Dr.Kanchana Baskaran, Vice Chancellor

Dr.Partha Sharathi Mallick, Pro-VC

Dr.T.Jayabarathi, Registrar

Convener

Dr.Mathew M Noel

Dean, School of Electrical Engineering

Dr.N.Amutha Prabha

Associate Dean, School of Electrical Engineering

Advisory Committee

Dr.Ponnambalam P

HoD, Dept. of Energy and Power Electronics

Dr.Jaganatha Pandian B

HoD, Department of Control and Automation

Dr.Sathish Kumar K

HoD, Department of Electrical Engineering

Dr.Rajini G.K.

HoD, Dept. of Instrumentation Engineering



ABOUT VIT

VIT was founded in 1984 as Vellore Engineering College by the Chancellor, Dr. G. Viswanathan. From its humble beginnings, the institution has grown exponentially to that of more than 35,000 students. It was conferred the University status in 2001 in recognition of its excellence in academics, research, and extracurricular initiatives. Currently, VIT has 5 campuses – in Vellore, Chennai, Amaravati (AP), Bangalore and Bhopal (MP). VIT has been consistently ranked among the best institutions of the country and is aspiring to emerge as a global leader. The National Institutional Ranking Framework (NIRF) of the MHRD, Government of India, has identified VIT as the best Private Engineering Institution in India. With students from all the states of India and from more than 50 countries, the cosmopolitan VIT provides an appropriate ambience for holistic learning and comfortable living. Sports, games and cultural activities are an integral part of student life on campus. VIT holds an exemplary placement record by consistently placing more than ninety percentage of the students in good companies. The VIT's international linkages provide ample opportunities for students and faculty to gain global exposure. VIT alumni, spread across the world, are serving the most-advanced as well as the most deprived.



ABOUT SELECT

School of Electrical Engineering (SELECT) has 98 faculty members who have done their UG and PG degrees from the top-notch universities. The school offers B.Tech. (Electrical and Electronics Engineering), B.Tech. (Electronics and Instrumentation Engineering), M.Tech. (Power Electronics and Drives) and M. Tech (Control and Automation), M.S. by Research and Ph.D. in Engineering. B. Tech (Electrical and Electronics Engineering) and B.Tech. (Electronics and Instrumentation Engineering), is accredited by the Engineering Accreditation Commission of ABET. All UG & PG programmes of the school are accredited by the Institution of Engineering and Technology (IET), the U.K. The placement record of the school has always been impressive. Almost 100% of the students get job from the campus placement and many of them are getting it in core companies every year. The school has state-of-the-art laboratories in almost all the areas of Electrical, Electronics and Instrumentation Engineering. Every year, students get scholarships to do their final year projects abroad under the Semester Abroad Program (SAP). Danfoss Industries Pvt. Ltd. India, Schneider Electric, India and NxP Semiconductors, India, have established Centre of Excellence for students R&D activities under the guidance of faculty members and industry experts. The school has signed MoUs with many foreign universities, research organizations and Industries from where students get benefits for their R&D Work / Projects from the MoUs.



FACULTY DEVELOPMENT PROGRAM

on
**DESIGN AND DEVELOPMENT OF
MICRO/SMART GRID INTENDED FOR
SMART CITY DEVELOPMENT AND
ENHANCING E-MOBILITY**
(18/11/2024 to 23/11/2024)

Coordinator

**Dr.S.Albert Alexander Ph.D., PDF (USA), SMIEEE.,
UGC-Raman Research Fellow**

Associate Professor

Co-Coordinator

Dr. Sonam Shrivastava

Assistant Professor



An initiative for Green Energy Transition

A REPORT ON

“DESIGN AND DEVELOPMENT OF MICRO/SMART GRID INTENDED FOR SMART CITY DEVELOPMENT AND ENHANCING E-MOBILITY”

Tomorrow’s digital cities will be the product of today’s dreams. Important elements in the creation of smart cities are the development of cohesive open telecommunication and software architecture, which will underpin the citizen-centric applications. These applications will also be applied in areas of national interest and social need, such as E-Health, Smart Energy and E-Education. The building blocks upon which smart cities will be created include smart and renewable energy; next-generation networks; smart buildings; smart transport and smart governance. To meet the goals of smart city in supporting a sustainable high-quality lifestyle for citizens, smart city certainly needs a smart grid. In this objective, this FDP intends to address the various renewable energy and smart grid technologies support in transforming the present cities to smart cities with aid of power electronics towards enhancing e-mobility.

Geotagged photos of the event with caption and date (at least 2 Nos)





Attendance
Effective implementation of OBE and nuances of accreditation process
18-11-2024 to 23-11-2024

LIST OF PARTICIPANTS

No.	Name	Email ID	Institute
1.	Chandan Kumar Sah	chandana6@protonmail.com	Annamalai university feat/ ficox electrical architect and engineer firm
2.	S Sundaramahalingam	sundar.eee@mepcoeng.ac.in	Mepco schlenk engineering college, sivakasi
3.	Jitendra Kumar Goyal	jitendrakg.rs.eee16@iitbhu.ac.in	Vit, vellore
4.	N.Amutha Prabha	amuthaprabha@vit.ac.in	Vit, vellore
5.	Abhishek Gudipalli	abhishek.g@vit.ac.in	Vit, vellore
6.	FX Edwin Deepak	edwindeepak-eee@nec.edu.in	National engineering college
7.	R M Brisilla	brisillamary@gmail.com	Vit, vellore
8.	V. Saravanan	vsaranaec@yahoo.co.in	Arunai engineering college
9.	Arockiaraj	arockiaraj.s@mepcoeng.ac.in	Mepco schlenk engg college
10.	Ponnambalam	p.ponnambalam@gmail.com	Vit, vellore
11.	K Karthik Kumar	karthik_eee@nec.edu.in	National engineering college
12.	Vijaya Priya R	vijayapriya.r@vit.ac.in	Vit, vellore
13.	YUVAPRIYA T	yuvapriya.t@vit.ac.in	Vit, vellore
14.	Jawahar M	jawahar.m@mepcoeng.ac.in	Mepco schlenk engineering college
15.	Mukul Chankaya	mukulchankaya@gmail.com	Vit, vellore
16.	Mrutunjaya Panda	mrutunjaya.panda@vit.ac.in	Vit, vellore
17.	N.Ravikumar	ravikumar21.rm@gmail.com	Chennai institute of technology

18.	M.Hemalatha	hemathichu@gmail.com	Sri Sai ram engg.college
19.	Chitra A	chitravenkat_pec@yahoo.co.in	Vit, Vellore
20.	Eswaran T	eswaranthangaraju@gmail.com	T s m jain college of technology
21.	T Porselvi	porselvi.eee@sairam.edu.in	Sri sairam engg. college
22.	RAVI K	rbjanani08@gmail.com	Vit, Vellore
23.	M.Ezhilmaran	suryapark2002@gmail.com	Chennai inst. of Tech.
24.	Dhanamjayulu C	dhanamjayulu.c@vit.ac.in	Vit, Vellore
25.	M.Priya	priya.m@vit.ac.in	Vit, Vellore
26.	Santharam M	msantharam175@gmail.com	Thiagarajar college of engineering
27.	Balasubramanian G	gbs.coolmce@gmail.com	Sastra university
28.	Manju T	manjut.phd@gmail.com	St. Joseph's institute of
29.	R Augasthega	augasthegar@gmail.com	St joseph's institute of
30.	Vishnupriyan	vishnupriyanj@citchennai.net	Chennai inst. of tech.
31.	Gowri Vidhya N	gowriavidhyanatarajan@gmail.com	St. Joseph's institute of
32.	Vinisha J	vinishavini9@gmail.com	St.joseph's institute of technology
33.	M Chrispin Das	mchrispindas@gmail.com	St.joseph's institute of
34.	Raju J	rajju@vit.ac.in	Vit, vellore
35.	M.Rajmaljosh	rajmaljoshi@gmail.com	Chennai inst. of Tech.
36.	Chittaranjan Nayak	chittaranjan.nayak@vit.ac.in	Vit, Vellore
37.	Varathan F	varathan.g2022@vitstudent.ac.in	Vit, Vellore
38.	K R Venkatesan	venkatesan.kr2023@vitstudent.ac.in	Vit, Vellore
39.	M Chethan	chethan.m2022@vitstudent.ac.in	Vit, Vellore
40.	K Ravindra Varma	ravindravarma.k2023@vitstudent.ac.in	Vit, Vellore
41.	N.Subramanian	subramanian.n2023a@vitstudent.ac.in	Vit, Vellore
42.	Sharmila D	sharmiidk@gmail.com	Vit, Vellore
43.	Sakthivel K	sakthivel314@gmail.com	Vit, Vellore

S. Sai Vastava
Signature of the Coordinator

Expenditure / Revenue Details of the Event

AICTE Sponsored



Signature of the Coordinator



Signature of the Dean

Dean
School of Electrical Engineering (SELECT)
Vellore Institute of Technology (VIT)
(Deemed to be University under section 3 of UGC Act, 1956)
Vellore – 632 014, Tamil Nadu, India

**VIT****Vellore Institute of Technology**

(Deemed to be University under section 3 of UGC Act, 1956)

CONFERENCE DETAILS**TRAINING PROGRAM DETAILS**

Event type	National Workshop		
Title of the event	Three Days Hands-on Training workshop on Characterization of Electrified Interfaces in Batteries and Supercapacitors		
Date (From – To)	13-11-2024 to 15-11-2024		
Time	09.00 -06.30 PM		
Venue	TT-712, Kamaraj Auditorium & V.O.C. Gallery in Technology Tower (TT-233)		
No. of Participants	130		
Co-ordinator	Emp. ID.	Faculty Name	Department
	12550	Dr. Palanisami N.	Centre for Functional Materials
	19745	Dr. Atul Thakre	Centre for Functional Materials
Resource Person Name	Prof. R. Kothandaraman; Prof. S. Natarajan; Prof. S. Sampath Prof. C. Retna Raj; Dr. P. Chandrakumar		
Designation	Professor; Professor; Professor; Professor; Technical Manager		
Organization Details	Indian Institute of Technology-Madras, Chennai Indian Institute of Science (IISc)- Bengaluru. Indian Institute of Science (IISc)- Bengaluru. Indian Institute of Technology (IIT)-Kharagpur. Metrohm's India private limited, Chennai		
Place	Chennai; Bengaluru; Bengaluru; Kharagpur; Chennai		
E-mail	rkraman@iitm.ac.in ; snatarajan@iisc.ac.in ; sampath@iisc.ac.in erraj@chem.iitkgp.ac.in ; chandra.kumar@metrohm.in		
Mobile no.	+91-9025111262; +91-8022932551; +91-8022933315; +91-322282252; +91-99406630238		

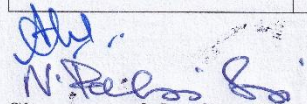
Signature of the Coordinators

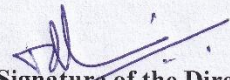
Signature of the Director

Dr. MADHURI W
Professor and Director
Centre for Functional Materials
Vellore Institute of Technology (VIT)
Vellore-632 014, Tamil Nadu, India

Brochure / Circular of the Event / Programme Schedule

November 13-15
ECS IITM STUDENT CHAPTER
THREE DAYS HANDS-ON TRAINING WORKSHOP ON CHARACTERIZATION OF ELECTRIFIED INTERFACES IN BATTERIES AND SUPERCAPACITORS
 (40th year celebrations of VIT)
CENTRE FOR FUNCTIONAL MATERIALS
VELLORE INSTITUTE OF TECHNOLOGY, VELLORE

OUR SPEAKERS

PROF. S SAMPATH
IISc. Bengaluru

PROF. S NATARAJAN
IISc. Bengaluru

PROF. C RETNA RAJ
IIT Kharagpur

PROF. KOTHANDARAMAN
IIT Madras

WORKSHOP INCLUDES
 LECTURES, QUIZZES, INTERACTIVE SESSIONS, & HANDS-ON DEMONSTRATION ON

- ELECTROCHEMISTRY FUNDAMENTALS
- BATTERIES
- SUPERCAPACITORS
- SOLAR CELLS
- GREEN HYDROGEN
- RAMAN SPECTROSCOPY AND MORE...

REGISTER NOW

LIMITED SEATS ONLY!!!

Registration Fee: Rs. 1200/ Last date for payment: 08-11-2024 Participation confirmation: 08-11-2024 Participation confirmation is on first come first serve basis. The seats are limited to maximum of 300. Registration fee includes registration kit, lunch & refreshments (Day 1-3) and participation certificate.

<https://events.vit.ac.in>

Accommodation: Accommodation can be provided to external participants in the hostels (dormitory) based on request. The tentative tariff for the dormitory is Rs. 500 (per day).

For More details: 9842659776

H₂

ABOUT VIT
 Vellore Institute of Technology was founded in 1984 as Vellore Engineering College by the honourable chancellor Dr. G. Viswanathan. The institution has grown steadily since its humble beginning. VIT attracts students from all over India and more than 50+ countries because of its excellence. Quality in teaching-learning, research and innovation make VIT a unique place to learn. The credentials in academics and research have placed VIT in the 11th position among the engineering institutions in India by NIRF, Govt. of India. QS World University Ranking by Subject 2024: 212th best institution in the world in Engineering and Technology.

ABOUT ECS IITM STUDENT CHAPTER
 The ECS IIT Madras Student Chapter (ECS IITM SC) was founded in October 2022 with a focus on skilling college students on required electrochemistry knowledge to take up research in electrochemistry-related areas such as batteries, fuel cells, sensors, electrodeposition, corrosion, electrosynthesis etc. The chapter regularly organizes workshops, lectures, and industrial visits, connecting students with academia and industry experts. Faculty advisors include Professors Kothandaraman Ramanujam, Raghuram Chetty, Ramanathan S, and Raman Vedarajan. Notable events include workshops on batteries, biosensors, and electrochemical energy storage. The chapter was awarded the "Chapter of Excellence 2023" by ECS.

ABOUT CFM
 The Centre for Functional Materials (CFM) at VIT, Vellore was established in Nov 2020. The Centre prioritizes the research of national interest by highlighting new findings and discussing current trends in technologically relevant topics. Here, we explore different classes of functional materials ranging from semiconductors to polymers and molecular crystals to nanoparticles. CFM has also provided various state-of-the-art characterization facilities like optical micro hardness, gas sensing, dielectric, electrical studies, etc. The Centre has gained attention due to its immense publications in the diverse fields of research in functional materials. CFM is offering a platform to connect a broad range of materials with focused research groups and support multidisciplinary research necessary for technology transfer. The Centre implements its mission via activities in research and education.

Facilities at CFM include Pulsed Laser deposition, DC and RF sputtering, Thermal & Electron Beam Evaporation, Electrochemical workstation, UV Lithography, Microhardness, Laser Shock Wave Peening and Z-scan etc.

Chief Patron
 Dr. G. Viswanathan Chancellor

Patrons
 Mr. Sankar Viswanathan Vice President
 Dr. Sekar Viswanathan Vice President
 Dr. G. V. Selvam Vice President

Co-Patrons
 Dr. V. S. Kanchana Bhaaskaran Vice Chancellor
 Dr. Partha Sharathi Mallick Pro-Vice Chancellor
 Dr. T. Jayabharathi Registrar

Chair Person
 Dr. R. Eshil Vathi Professor & Director CFM

Conveners
 Dr. N. Palanisami Professor
 Dr. Anil Thakre Asst. Professor

Nikhil G Mohan (President ECS IITM SC)

Members
 Dr. S. Kalaemulla Professor
 Dr. W. Madhuri Professor
 Dr. Ramesh M Thamanikar Professor
 Dr. S. Madeswaran Asst. Professor
 Dr. Ankur Rastogi Asst. Professor
 Dr. Amlan Das Asst. Professor

For More details: 9842659776 (palanisami.nevit.ac.in) 9650595952 (anil.thakre@vit.ac.in)

Three Days Hands-On Training Workshop on Characterization of Electrified Interfaces in Batteries and Supercapacitors
 40th year celebration of VIT, Vellore
13-15, November 2024
 Organized by
 Centre for Functional Materials (CFM), Vellore Institute of Technology, Vellore.
 ECS-IITM Student Chapter and Metrohm India Private Limited.

Schedule Day-1, November 13 th , 2024	
Time	Events
Venue: V.O.C. Gallery in Technology Tower (TT-233)	
08:30 am - 09:30 am	Registration
09:30 am - 10:00 am	Inaugural Function and Photo Session
10:00 am - 11:30 am	Inaugural Lecture: Prof. S. Natarajan, Indian Institute of Science, Bangalore Title: Solid State Batteries: A Solid State Chemist's View
11:30 am - 11:45 am	Tea Break
11:45 am - 01:15 pm	Invited Talk: Prof. R. Kothandaraman, Indian Institute of Technology, Madras Title: Basics of Electrochemistry for Batteries
01:15 pm - 02:30 pm	Lunch Break (VIT Main Canteen)
Venue: Kamaraj Auditorium in Technology Tower (TT-712)	
02:30 pm - 03:30 pm	Hands-On Training Session
03:30 pm - 03:50 pm	Tea Break
03:50 pm - 05:00 pm	Hands-On Training Session
Schedule Day-2, November 14 th , 2024	

Venue: V.O.C. Gallery in Technology Tower (TT-233)	
09:30 am - 11:00 am	Invited Talk: Prof. C. Retna Raj, Indian Institute of Technology, Kharagpur Title: Metal-air Batteries: Principles and Practices
11:00 am - 11:30 am	Tea Break
11:30 am - 01:00 pm	Invited Talk: Nikhil G Mohan, Indian Institute of Technology, Madras Title: Impedance Spectroscopy
01:00 pm - 02:15 pm	Lunch Break (VIT Main Canteen)
Venue: Smart Class Room (TT-513)	
02:15 pm - 03:45 pm	Interactive Session: Prof. C. Retna Raj, Indian Institute of Technology, Kharagpur Ask Me Anything, Q&A session
03:45 pm - 04:00 pm	Tea Break
Venue: Kamaraj Auditorium in Technology Tower (TT-712)	
04:00 pm - 05:30 pm	Hands-On Training Session
Schedule Day-3, November 15 th , 2024	
Venue: V.O.C. Gallery in Technology Tower (TT-233)	
09:30 am - 11:00 am	Invited Talk: Prof. S. Sampath, Indian Institute of Science, Bangalore Title:
11:00 am - 11:30 am	Tea Break
	Invited Talk: Prof. R. Kothandaraman, Indian Institute of Technology, Madras Title: Redox Flow Batteries for Grid Level Energy Storage
01:00 pm - 02:15 pm	Lunch Break (VIT Main Canteen)
Venue: Kamaraj Auditorium in Technology Tower (TT-712)	
02:15 pm - 03:30 pm	Hands-On Training Session
Venue: V.O.C. Gallery in Technology Tower (TT-233)	
03:30 pm - 04:00 pm	Valedictory Function
04:00 pm	High Tea

A Report on

Three-Day Hands-on Training Workshop on Characterization of Electrified Interfaces in Batteries and Supercapacitors

Three-Day Hands-on Training Workshop on Characterization of Electrified Interfaces in Batteries and Supercapacitors, which is Ruby Jubilee 40th year celebrations of VIT, Vellore was jointly organized between 13th -15st November 2024 by the Centre for Functional Materials of Vellore Institute of Technology (VIT)-Vellore and collaboration with jointly organised by ECS-IITM Student Chapter and Metrohm India Private Limited. 130 students were registered from various academic institutions across the country and out of them 47 students from other institutes. 12 technical and 3 hands-on sessions were conducted over 3 days. The student participants were involved enthusiastically in both theory and hands-on sessions. The objective of the training program was achieved by the active involvement of research scholars and students and satisfied the expectations of the participants.

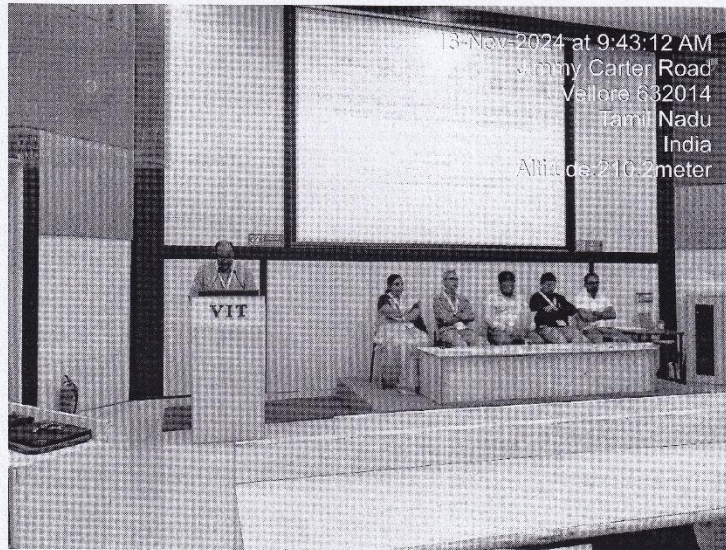

N. Subramanian
Signature of the Coordinator

Expenditure / Revenue Details of the Event

Three-Day Hands-on Training Workshop on Characterization of Electrified Interfaces in Batteries and Supercapacitors, which is Ruby Jubilee 40th year celebrations of VIT, Vellore was jointly organized between 13th -15st November 2024 by the Centre for Functional Materials of Vellore Institute of Technology (VIT)-Vellore and collaboration with jointly organised by ECS-IITM Student Chapter and Metrohm India Private Limited was held for the benefit of researchers and students. The revenue was generated from registration fees (Rs. 127050/-; excluding GST). The total expenditure of this event is Rs. 99740/-.

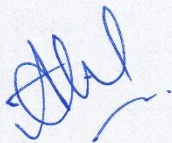

N. Pullosi Sasi

Signature of the Coordinators

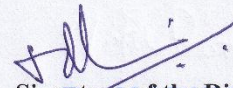

Signature of the Director
Professor and Director
Centre for Functional Materials
Vellore Institute of Technology (VIT)
Vellore-632 014, Tamil Nadu, India



Vellore-632014, Tamil Nadu, India

School of Electrical Engineering

Department of Energy and Power Electronics

5-Day Online Workshop on Embedded Systems in Electric Vehicles

Program Details

Event type	Workshop		
Title of the event	5-Day Online Workshop on Embedded Systems in Electric Vehicles		
Date (From – To)	11 th to 15 th November 2024		
Time	10.00 AM to 5.00 PM		
Venue	Google Meet - Online		
No. of Participants	61		
Coordinator(s)	Emp. ID.	Faculty Name	Department
	15295	Dr. Y P. Obulesu	Energy and Power Electronics
	17037	Dr. Jakeer Hussain	Energy and Power Electronics

Resource persons details:

Name	Designation	Organization	e-mail
Ms. Meghana	Embedded Systems Engineer	Valeo India Ltd, Chennai	meghana.ravi@valeo.com
Dr. Srinivas	Technical Specialist	TATA Elxsi, Hyderabad	s.srinivas241@gmail.com
Mr. Rakesh	Software Engineer	Borgwarner, Bangalore	rb@borgwarner.com
Mr. Jayadeep	Software Technical Lead	Borgwarner, Bangalore	ivi@borgwarner.com
Dr. Krishna Kishore Mugada	Assistant Professor in dept. of mechanical engineering	Sardar Vallabhbhai National Institute of Technology Surat.	kkm@med.svnit.ac.in
Dr. Venkata Sainath	Technical Specialist	Mercedes Benz, Bangalore, India	bondadasai@gmail.com
Dr. S.L.V. Sravan Kumar	Technical Specialist	ZF Embedded Systems, Hyderabad	lakshmivenkatasravan.soma@zf.com
Dr. Y.P. Obulesu	Professor in School of Electrical Engineering	Vellore Institute of Technology Vellore	yp.obulesu@vit.ac.in
Dr. P. Ponnambalam	Professor in School of Electrical Engineering	Vellore Institute of Technology Vellore	ponnambalam.p@vit.ac.in
Dr. Ram Mohan A	Associate Professor in Dept of Automotive Engineering	Vellore Institute of Technology Vellore	rammohan.a@vit.ac.in

Dr. Mrutyunjaya Panda	Assistant Professor in School of Electrical Engineering	Vellore Institute of Technology Vellore	mrutyunjay.panigrahi@vit.ac.in
Dr. Jakeer Hussain	Assistant Professor in School of Electrical Engineering	Vellore Institute of Technology Vellore	jakeer.hussain@vit.ac.in

Faculty coordinators

Dr. Y.P. Obulesu, 

Dr. Jakeer Hussain

Dean

Dr. Mathew M Noel

**SELECT
Dean**
School of Electrical Engineering (SELECT)
Vellore Institute of Technology (VIT)
(Deemed to be University under section 3 of UGC Act, 1956)
Vellore – 632 014, Tamil Nadu, India

Brochure:

ORGANIZING COMMITTEE

Chief Patron

Dr. G. Viswanathan, Chancellor

Patrons

Thiru. Sankar Viswanathan, Vice President

Dr. Sekar Viswanathan, Vice President

Dr. G.V.Selvam, Vice President

Dr. V. S. Kanchana Bhaaskaran, Vice Chancellor

Dr. Partha Sharathi Mallick, Pro-Vice Chancellor

Dr. T. Jayabarathi, Registrar

Organizing Chair

Dr. Mathew Mithra Noel, Dean, SELECT

Dr. Amutha Prabha. N, Associate Dean, SELECT

Conveners

Dr. Ponnambalam, P, HoD, Energy & Power Electronics

Dr. Jaganatha Pandian. B, HoD, Control & Automation

Dr. Rajini. G.K, HoD, Instrumentation

Dr. Thiruvenkadam, HoD, Electrical Engineering

Coordinators

Dr. Y. P. Obulesu, Professor,

Dept of Energy & Power Electronics

Ph: +91 99667 47042

e-mail: yp.obulesu@vit.ac.in

Dr. Jakeer Hussain, Assistant Professor

Dept of Energy & Power Electronics

Ph: +91 99626 04835

e-mail: jakeer.hussain@vit.ac.in

REGISTRATION

Prospective participants are requested to register for the workshop through the following web link:

<https://events.vit.ac.in/>

Registration Fee

For students (UG, PG, Ph.D): Rs. 500 + 18% GST

Faculty : Rs 1000 + 18% GST

The main Course Contents:

- ❖ Electric vehicle drive trains
- ❖ Design aspects of Electric vehicle components
- ❖ EV traction motor control strategies
- ❖ Model based design of EV components using MATLAB/SIMULINK
- ❖ Testing of embedded systems of EVs
- ❖ Design of Battery management system
- ❖ Automotive embedded controllers for EVs
- ❖ Embedded controllers and programming

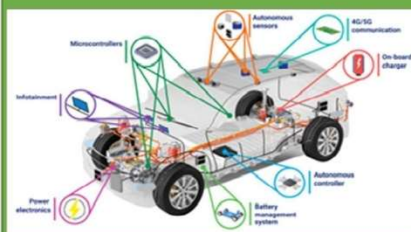

5-day online workshop on Embedded systems in Electric Vehicles

11th – 15th November 2024

Organized by
Department of Energy & Power Electronics,
School of Electrical Engineering,
Vellore Institute of Technology,
Vellore-632014, Tamilnadu, India

Vellore Institute of Technology (VIT)

VIT, Vellore was founded in 1984 as Vellore Engineering College by the Founder and Chancellor Dr. G. Viswanathan. University status was conferred in 2001 by MHRD Govt. of India in recognition of its excellence in academics, research and extracurricular initiatives.

VIT has emerged as one of the best institutes of India and is aspiring to become a global leader. Quality in teaching-learning, research and innovation makes VIT unique.

- Engineering and Technology subject areas of VIT are the 240th best in the World and the 9th best in India, and eight subjects of VIT are within the top 500 in the world (as per QS World University Rankings by Subject 2023).
- The 8th best University, the 11th best research institution and the 11th best engineering institution in India (NIRF Ranking, Govt. of India 2023).
- Ranked among the top 600-800 Universities of the world (THE World University Ranking 2024).
- NAAC Accreditation with A++ grade (3.66 out of 4).
- The 173rd best Institution in Asia (QS - Asia University Rankings 2023).

About the School

The School of Electrical Engineering (SELECT) offers B.Tech. in Electrical and Electronics Engineering, Electronics and Instrumentation Engineering, Electrical and Computer Science Engineering, M.Tech. in Power Electronics and Drives, Control and Automation, Ph.D. and Integrated Ph.D. in Engineering. The programmes are accredited by the Engineering Accreditation Commission of ABET and Institution of Engineering and Technology (IET), U.K. The school played a key role in securing a QS Subject Ranking in Electrical and Electronics Engineering between 201-250 globally and ranking 8th in India.



The school has state-of-the-art laboratories in almost all the areas of Electrical, Electronics and Instrumentation Engineering. SELECT has industry sponsored advanced laboratories for performing world class research and consultancy. The school's industry partners Danfoss, Schneider Electric Smart Energy, Schneider Electric Building Automation, Fluke, Q-Max Automated Test Engineering and NxP Semiconductors, India, have established Centre of Excellence for students R&D activities under the guidance of faculty members and industry experts.

The students are encouraged to take advantage of the growing opportunities by incorporating an international internship experience in their final year undergraduate and postgraduate education. Students are also motivated to opt for twin degree programs with various reputed universities across the globe. Every year, students get scholarships to do their final year projects abroad under the Semester Abroad Program (SAP). The school's pre-incubation cell supports product development, patent filing and start-up enthusiasts.

About the Department

The Department of Energy and Power Electronics provides a platform for the creation and application of power electronics technology in multidisciplinary fields to provide clean and sustainable energy.



The courses are designed to provide well-balanced theory and hands-on training in Power Electronics, drives and controls, Electric Vehicles, Embedded control and more to meet the demand of industries. Through specific courses the graduates are employed in Drives, Embedded, Automobile and pharmaceutical industries in addition to career as a researcher in premiere institutes in India and abroad.

About the workshop

Lecture series on EV technologies is designed for students, research scholars, and working professionals to enhance their domain knowledge. This lecture series will help the participants to understand the various technologies involved in the complex electric vehicle system like electronic control units (ECUs), electric motors, power electronic converters, battery storage systems, etc. This lecture series will facilitate the participants to choose their career in electric vehicle sector.

Learning Outcomes

- Understanding of various components of electric vehicles
- Automotive embedded controllers for Electric vehicles

Program Schedule:



5-day online workshop on "Embedded systems in Electric Vehicles" 11th to 15th November 2024

Date	10.0 AM to 11.15 AM	11.15 to 11.30	11.30 AM to 1.0 PM	1.0 PM to 2.0PM	2.0 PM to 3.15 PM	3.15 to 3.30	3.30 PM to 5.0 PM
11 th Nov 24	Dr.YP Obulesu, VIT Vellore Electric Vehicle components	Tea break	Dr.YP Obulesu, VIT Vellore ECUs in Electric Vehicles	Lunch break	Dr.Kishore, SVNIT Surat Mechanical design aspects in EV	Tea break	Dr. Ponnambalam.P VIT Vellore ARM processor for EVs
12th Nov 24	Dr.Mrutyunjaya Panda, VIT Vellore Generation of PWM Pulses for EV converter using FPGA board		Dr. Ponnambalam.P VIT Vellore ARM processor for EVs		Dr.Sainath, Mercedes Benze Hands-on Explainable AI (XAI) using SHAP and Integrated gradients		Dr.Kishna Kishore, SVNIT Surat Battery Pack Manufacturing
13th Nov 24	Meghana, valeo India Ltd Low voltage BLDC motor drives, challenges and solutions		Meghana, Valeo India Low voltage BLDC motor drives, challenges and solutions		Dr.Mrutyunjaya Panda, VIT Vellore Generation of PWM Pulses for EV converter using FPGA board		Dr.Jakeer Hussain, VIT Vellore Embedded Programming using STM 32 MCU
14th Nov 24	Mr.Jayadeep, Borgwarner ASIC and MCUs for EVs-part1		Mr.Rakesh.B, Borgwarner ASIC and MCUs for EVs-part2		Dr.Sainath, Mercedes Benze Introduction to Embedded AI		Dr.Jakeer Hussain, VIT Vellore Embedded Programming using STM 32 MCU
15th Nov 24	Dr.Srinivas, PDSL Design and implementation of BMS		Dr.Srinivas, PDSL Design and implementation of BMS		Dr.Rama mohan, ARC, VIT Vellore Fault diagnosis of Electric Vehicle		Dr.Sravanakumar, ZF embedded systems Model Based Design for EV and HEV

Report on

5-Day Online Workshop: Embedded Systems in Electric Vehicles

Objective:

Lecture series on EV technologies is designed for students, research scholars, and working professionals to enhance their domain knowledge on Electric Vehicles. This lecture series will help the participants to understand the various technologies involved in the complex electric vehicle system like electronic control units (ECUs), electric motors, power electronic converters, battery storage systems, etc. This lecture series will facilitate the participants to choose their career in electric vehicle sector.

Learning Outcomes:

- Understanding of various electric components used in electric vehicles
- Understanding of various mechanical design aspects of electric vehicles
- Role of microcontrollers (especially ARM controllers) in infotainment systems of electric vehicles
- Application of FPGA systems for the generation of PWM pulses to control propulsion of electric vehicles.
- Details of battery pack manufacturing
- Design of BLDC motor drives for electric vehicles
- Getting aware of various ASICs and MCUs for various subsystems of electric vehicles
- Model based design in the development of electric and hybrid electric vehicles
- Design and implementation of battery management system in electric vehicles

5 Day Online Workshop on “Embedded systems in Electric Vehicles”
11 to 15th November 2024

 **VIT**
Vellore Institute of Technology
Established by Government order on 17/12/1984

Battery pack development in an Electric Vehicle

Dr. Krishna Kishore Mugada,
Assistant Professor
Department of Mechanical Engineering

Vedant Jagan Mali 24BEE0185

 Sardar Vallabhabhai National Institute of Technology, Surat,
Gujarat, India-395007.
Email: kkm@med.svnit.ac.in; Phone: +91 9505674467 / +91-7569617706.

Hands on XAI using SHAP and Integrated Gradients

by

Mr. Bondada Venkatasainath
B.Tech, M.Tech, (PhD) - IIT KHARAGPUR
PGDAS - ISI Kolkata

Senior Technical Lead
Mercedes-Benz Research and Development India Pvt. Ltd



Sai nath

Low Voltage BLDC motor drives, challenges and solutions

Meghana Ravi
VALEO
Electronics Engineer



Meghana RAVI

Principle of operation

- BLDC motor is a permanent magnet on the rotor of the motor, which is surrounded on the stator by coil that act as electromagnets when current is injected into them.
- By successively injecting current to different coils a moving magnetic field is generated that continuously drags the rotor along the circle.
- This is the basic concept of how a BLDC motor is spun.
- This process of switching which coils have current injected to generate motion is called commutation.

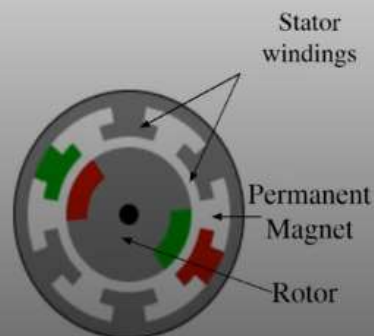

Meghana RAVI

The screenshot shows a Google search for 'neural network'. The search results include several articles and videos. A prominent diagram of a neural network is visible, showing an 'Input nodes layer' with three nodes (input x1, input x2, input x3), a 'Hidden nodes layer' with three nodes, and an 'Output nodes layer' with two nodes (output y1, output y2). The diagram is labeled with 'Links' and 'Neurons'. Below the diagram, there is a video player for 'Evolution and Concepts Of Neural Networks | Deep Learning'.



Sai nath

ASICs

What is an ASIC?

ASICs are specialized integrated circuits designed to perform a specific task or function, unlike general-purpose processors that handle multiple tasks.

Example: ASICs in mobile devices for signal processing.

Importance of ASICs in Embedded Systems

Embedded systems require optimized, efficient, and often resource-limited hardware to meet specific performance goals. ASICs offer custom functionality tailored to these needs.



R

Rakesh B

Workshop Flow – Agenda

Introduction to ECU's

Selection of Microcontroller

AUTOSAR Layered Architecture and MCAL

Functional Safety

Basic of ASIC

ASICs in EV

Embedded Tools

Conclusion

2 VIT Workshop on Embedded Systems in EVs

BORGWARNER



jayadeep v.j

Safety Concepts and Practices in EVs

- **System Architecture and Redundancy:** High-voltage systems and battery management systems incorporate redundancy for fault tolerance.
- **Safety Mechanisms:** Include overcurrent protection, thermal management, and cooling systems.
- **Failure Modes and Diagnostic Analysis:** Use methods like FMEA and diagnostic coverage to identify and mitigate risks.



jayadeep v.j

5 Day Online Workshop on "Embedded systems in Electric Vehicles"
11 to 15th November 2024



VIT
Vellore Institute of Technology
(Deemed to be University under section 3 of UGC Act, 1956)

Aerodynamics of an Electric Vehicle

Dr. Krishna Kishore Mugada
Assistant Professor
Department of Mechanical Engineering



Dr. Krishna Kishore M SVNIT



Sardar Vallabhbhai National Institute of Technology, Surat,
Gujarat, India-395007.
Email: kkm@med.svnit.ac.in; Phone: +91 9505674467 / +91-7569617706.



VIT
Vellore Institute of Technology
(Deemed to be University under section 3 of UGC Act, 1956)

Working with STM32 (ARM) MCUs

Dr. Jakeer Hussain
School of Electrical Engineering
jakeer.hussain@vit.ac.in



VIT - Recognized as Institution of Eminence (IIE) by Government of India



Jakeer Hussain

Generation of PWM pulse for EV converter using FPGA



VIT
Vellore Institute of Technology
(Deemed to be University under section 3 of UGC Act, 1956)

Dr. Mrutunjaya Panda
Assistant Professor
School of Electrical Engineering
VIT, Vellore, Tamil Nadu, India, 632014



Jakeer Hussain



Battery Management System (BMS)

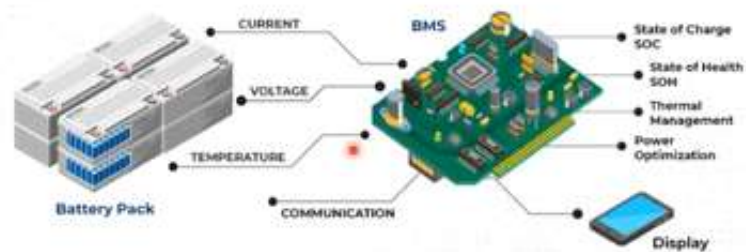

The purpose of a BMS is to:

- Provide battery safety and longevity
- Estimate State of Charge, State of Health, State of Power and State of Energy
- Prompt caution and service (high temperature, cell imbalance or calibration)
- Indicate end-of-life when the capacity falls below the user-set target threshold.

Integrated Motor Controller Performance:

- The DRV series integrated driver combines all control logic circuits, gate drivers, protection circuits, commutation blocks, sensing circuits on a single chip providing the best solution especially for low power motor applications.

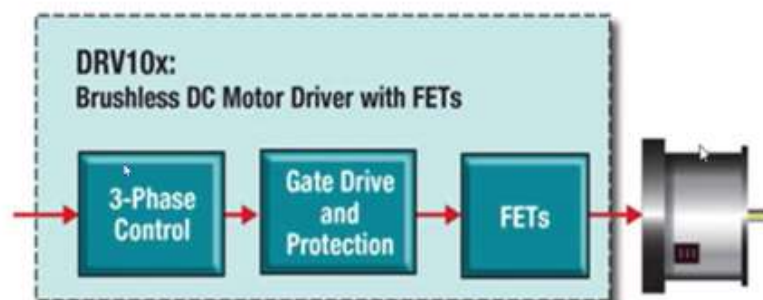

Major components of BMS

BMS consists of

1. BMS main microcontroller
2. Analog Front End (AFE)
3. Communication interface

Functions of the AFE

- **Cell Monitoring:** monitors cell parameters such as voltage, current, and temperature.
- **Cell Balancing:** The AFE performs cell balancing by redistributing charge among individual cells.
- **Local Control:** autonomously manages its assigned cells.
- **Safety Functions:** It detects abnormal conditions (e.g., overvoltage, undervoltage, overtemperature)



BMS Main Controller

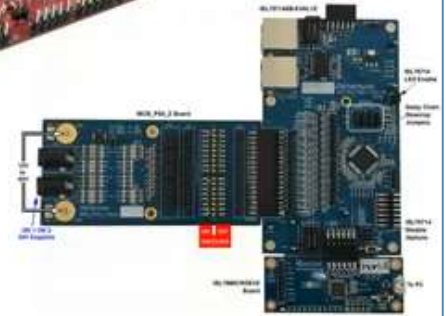

AFE

Thermal Management System

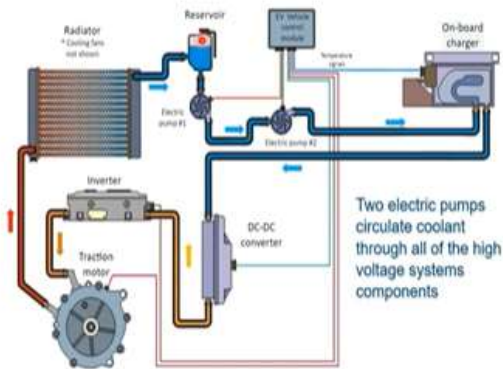

[9]

Battery Capacity & Battery Life Compared at Different Temperatures

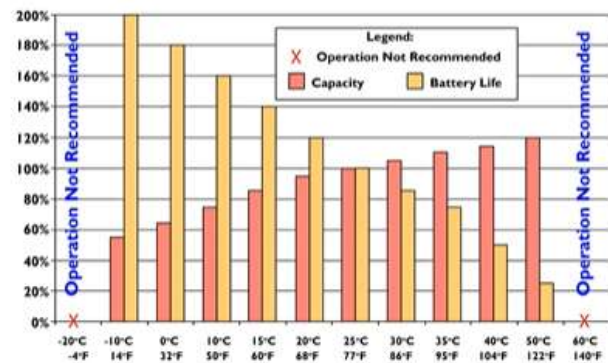

EV charging

Major High voltage Components:

- ✓ High voltage Battery Pack
- ✓ On board Charger (OBC)
- ✓ DC-DC Converter
- ✓ Inverter
- ✓ Motor
- ✓ Battery management system

What is High Voltage:

Any voltage above 60V DC is considered as a high voltage in Automotive domain

From this level, the need for contact protection becomes mandatory

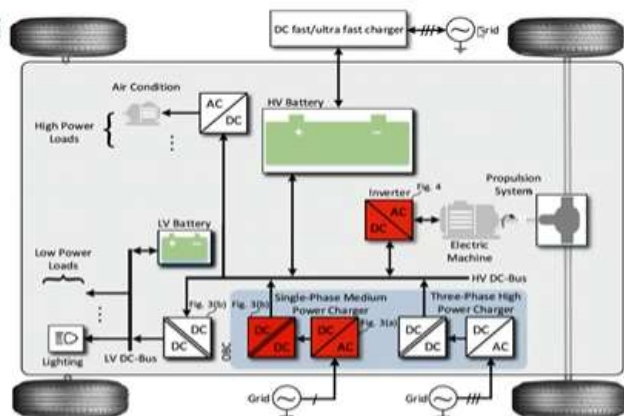

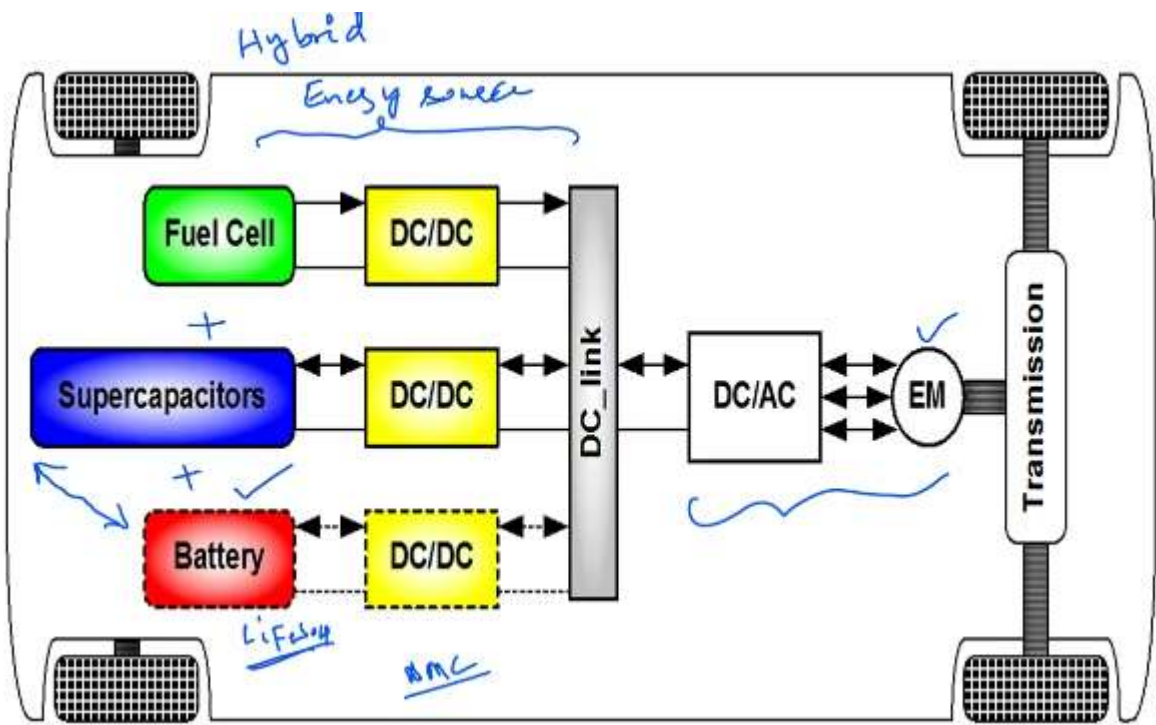

Distributed Architecture

Contrasting with centralized systems, a distributed architecture delegates functions across numerous Electronic Control Units (ECUs) positioned throughout the vehicle, with each ECU tailored to handle particular tasks or task sets.

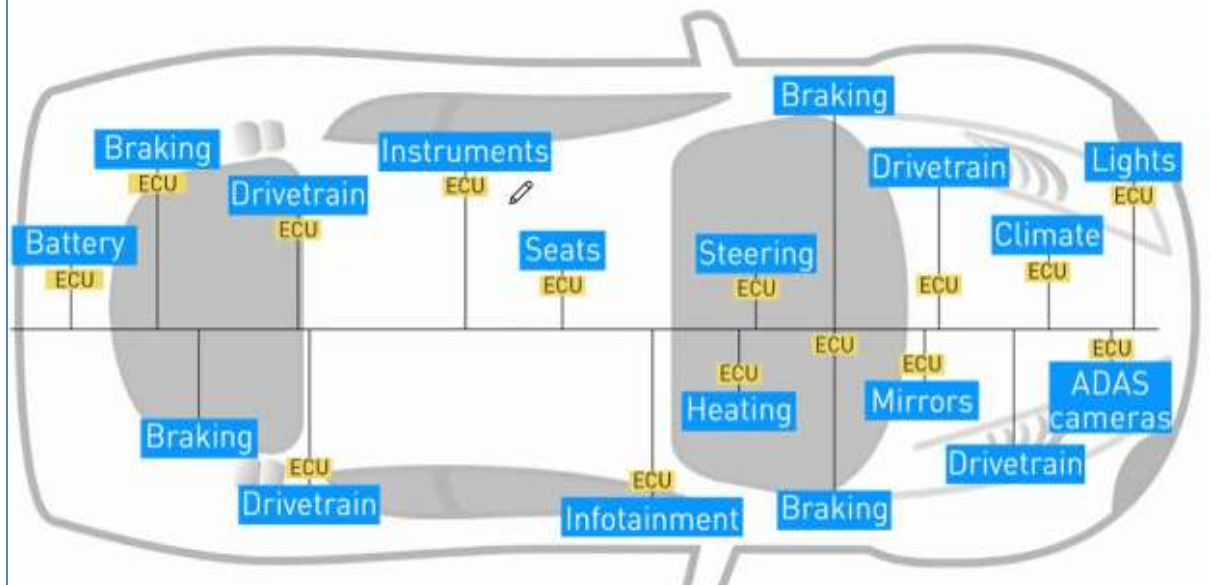



Attendance

5-Day Online Workshop: Embedded Systems in Electric Vehicles

11th to 15th November 2024

S.No	Name	Institution / Organization	E-Mail	Paid Amount
1	R MEGHANA	VIT, VELLORE	rallapalli.meghana2024@vitstudent.ac.in	590
2	RANESH S	VIT, VELLORE	ranesh.s2024@vitstudent.ac.in	590
3	JYOTHILAKSHMI B	VIT VELLORE	jyothilakshmi.b2024@vitstudent.ac.in	590
4	SAMRUDDHI VILAYATKAR	VIT, VELLORE	samruddhi.sunil2024@vitstudent.ac.in	590
5	SAIRAJ ARANDHAKAR	NIT ANDHRA PRADESH	sairajphd@gmail.com	590
6	B SREYAS	VIT VELLORE	sreyas.b2024@vitstudent.ac.in	590
7	PANISETTY SREENIVASULU	VIT, VELLORE	panisetty.sreenivas2020@vitstudent.ac.in	590
8	VIJAYAKRISHNA	VIT, VELLORE	vijayakrishna.r2024@vitstudent.ac.in	590
9	THOTA THARUN	VIT, VELLORE	thota.tharun2024@vitstudent.ac.in	590
10	VALLABH BHAT	SELECT SCHOOL, VIT VELLORE	vallabh.bhat2024@vitstudent.ac.in	590
11	ARUNSENTHIL.G	VIT, VELLORE	arunsenthil.g2024@vitstudent.ac.in	590
12	RAKSHITHA G BAJAJ	VIT, VELLORE	rakshitha.gbajaj2024@vitstudent.ac.in	590
13	K SRINIVASA RAO	ANURAG UNIVERSITY	srinivasarao.eee@anurag.edu.in	590
14	PATHAKAMURI SAI KEERTHANA	SRI VENKATESWARA INSTITUTE OF TECHNOLOGY	saikeerthanapatakamuru@gmail.com	590
15	PRITEE ANIL GIRASE	VIT, VELLORE	pritee.anilgirase2024@vitstudent.ac.in	590
16	JAYAKARA BABU KONDRU	VIT, VELLORE	jaykarcrraze@gmail.com	590
17	YELLAPUREDDY VIJAY KUMAR	NIT WARANGAL	yv21eerep08@student.nitw.ac.in	590
18	SUNEETHA UPPALA	SRI VENKATESWARA INSTITUTE OF TECHNOLOGY	drsuneethauppala@gmail.com	590
19	VANGA.ANIL	VIT VELLORE	vanga.anil2020@vitstudent.ac.in	590
20	KARTHIK K	VIT VELLORE	karthik.k2020@vitstudent.ac.in	590
21	SULAKE KAVYA SREE	SRI VENKATESWARA INSTITUTE OF TECHNOLOGY	sulakekavya99@gmail.com	590
22	UDHAYAKUMAR KARTHIKEYAN	VIT, VELLORE	udhayakumar.k@vit.ac.in	590
23	SENCHUGARLA SUMALATHA	VIT-VELLORE	senchugarla.2023@vitstudent.ac.in	590
24	SYED BABA SHARIFF	VIT, VELLORE	syed.babashariff2024@vitstudent.ac.in	590
25	ANUGRAHA P	VIT, VELLORE	anugraha.p2021@vitstudent.ac.in	590
26	KARUR MEHARUNNISA BEGUM	SVIT ANANTAPUR	meharun0401@gmail.com	590
27	DR. SHEELA S J	SIDDAGANGA INSTITUTE OF TECHNOLOGY	sheeladinu@sit.ac.in	1,180.00
28	RAJESWARI.V	SRI VENKATESWARA COLLEGE OF ENGINEERING	rajibe31@gmail.com	590
29	CHAMA VINISHA	SRI VENKATESWARA INSTITUTE OF TECHNOLOGY	vinishareddy2002@gmail.com	590
30	ROOPAK MADDARA	SRI VENKATESWARA INSTITUTE OF TECHNOLOGY	roopakmaddara@gmail.com	590

31	ALAKUNTA UMADEVI	SRI VENKATESWARA INSTITUTE OF TECHNOLOGY	umadevialakunta123@gmail.com	590
32	SUNDAR K	THANTHAI PERIYAR GOVERNMENT INSTITUTE OF TECHNOLOGY	sundarfscop@gmail.com	590
33	DHARANI M	VELLORE INSTITUTE OF TECHNOLOGY, VELLORE	dharani.m2020@vitstudent.ac.in	590
34	SHILPASHRI V N	GSSS INSTITUTE OF ENGINEERING & TECHNOLOGY FOR WOMEN, MYSURU	shilpashri@gsss.edu.in	590
35	DHARAVATH RAMESH	NIT TRICHY	rameshnitt1995@gmail.com	590
36	S KEERTHANA	SRI VENKATESWARA COLLEGE OF ENGINEERING	keerthana170897@gmail.com	590
37	MOHAMMAD ISA MIRZA	VIT, VELLORE	mohammadisa.mirza2021@vitstudent.ac.in	590
38	VEDANT JAGAN MALI	VIT, VELLORE	vedant.jaganmali2024@vitstudent.ac.in	590
39	KOTA SRILAKSHMI LAVANYA	LAKIREDDY BALI REDDY COLLEGE OF ENGINEERING	ksllavanya4@gmail.com	1,180.00
40	YARLAGADDA RAGHUVAMSI	LAKIREDDY BALI REDDY COLLEGE OF ENGINEERING(A), MYLAVARAM	vamsi777raghu@gmail.com	1,180.00
41	SAI SURIYA R.K	SRI VENKATESHWARA COLLEGE OF ENGINEERING	2024pd0009@svce.ac.in	590
42	YUKESH KUMAR T	SRI VENKATESHWARA COLLEGE OF ENGINEERING	2024pd0004@svce.ac.in	590
43	Y VIJAYA SAMBHAVI	VIT, VELLORE	vijayasambhavi.y2021@vitstudent.ac.in	590
44	VAISHAKH V	VIT VELLORE	vaishakh.v2024@vitstudent.ac.in	590
45	Mr. Wayphale Nilesh Shivaji	PLATEMASTERS, PUNE	laser.nilesh@gmail.com	1,180.00
46	BHURE HARSHAL RAVIRAJ	VIT, VELLORE	harshal.bhure2021@vitstudent.ac.in	590
47	GEETIKA SAWKARE	VIT VELLORE	geetika.niraj2023@vitstudent.ac.in	590
48	BAGADI CHANDRA SEKHAR	VIT, VELLORE	bagadi.chandra2023@vitstudent.ac.in	590
49	P.ARSHIYA KHANAM	SANSKRITHI SCHOOL OF ENGINEERING, PUTTAPARTHI	arshiyab7720@gmail.com	590
50	S.BABA IMROZ	SANSKRITI SCHOOL OF ENGINEERING	niranjan143kittu@gmail.com	590
51	SANDEEP S D	VIT, VELLORE	sandeep.sd2020@vitstudent.ac.in	590
52	BESTHA	SANSKRITHI SCHOOL OF ENGINEERING	marena2256@gmail.com	590
53	JAKKA HEMANTH SAI	SANSKRITHI SCHOOL OF ENGINEERING, PUTTAPARTHI	hemanthsai224488@gmail.com	590
54	CHAKALI YESHWANTH KUMAR	SANSKRITHI SCHOOL OF ENGINEERING	yeshwanthc77@gmail.com	590
55	PRAVEEN KANNA S	VIT, VELLORE	praveenkanna.s2024@vitstudent.ac.in	590
56	SUGUMARAN G	VIT, VELLORE	sugumaran.g2020@vitstudent.ac.in	590
57	PALLAMKUPPAM VINODH KUMAR	SANSKRITHI SCHOOL OF ENGINEERING, PUTTAPARTHI	pallamkuppamvinodhkumar@gmail.com	590
58	KARAN KUMAR K	VIT, VELLORE	karankumar.k2020a@vitstudent.ac.in	590
59	VENKATESAN K R	VIT UNIVERSITY	venkatesan.kr2023@vitstudent.ac.in	590
60	NITHYA	VIT, VELLORE	nithya.2023@vitstudent.ac.in	590
61	RAMSHANKAR S	VIT	ramshankar.s2023@vitstudent.ac.in	590

Expenditure / Revenue Details of the Event
5-Day Online Workshop: Embedded Systems in Electric Vehicles
11th to 15th November 2024

Total number of participants: 61

Revenue generated:

Registrations	Total no.of participants	Registration fee, Rs	Total Rs
UG students	13	590	7670
PG/ Research scholars	44	590	25960
Faculty	4	1180	4720
Total Registration fee (UG+PG/PHD+FACULTY) = 38350 - 18% GST = 6903 Total Registration fee excluding GST: Rs. 31447			

Expenditure:

Expenditure	1 st day	2 nd day	3 rd day	4 th day	5 th day
Honorarium to resource persons	6000	6000	6000	6000	9000
Total expenditure for 5 days (honorarium) = Rs. 33000					

Balance amount = (Revenue – Expenditure)

= Rs. 31447 - Rs. 33000 = Rs. -1553 /-

Balance to be paid to the resource persons: Rs. 1553.00 (Rupees One thousand five hundred and fifty three only).

Faculty coordinators

Dr. Y.P. Obulesu, 

Dr. Jakeer Hussain



Dean

Dr. Mathew M Noel

SELECT
Dean
School of Electrical Engineering (SELECT)
Vellore Institute of Technology (VIT)
(Deemed to be University under section 3 of UGC Act, 1956)
Vellore – 632 014, Tamil Nadu, India



VIT School of Architecture

~~VALUE ADDED / GUEST LECTURE / SEMINAR / WORKSHOP / SYMPOSIUM / CONFERENCE / TRAINING PROGRAM DETAILS~~

Event type	International Conference		
Title of the event	<u>11th Zero Energy Mass Custom Home International Conference 2024</u>		
Date (From – To)	8th and 9th November 2024		
Time	10.00 am to 6.00 pm		
Venue	Gandhi block, VIT		
No. of Participants	532		
Coordinator(s)	Emp. ID.	Faculty Name	Department
	16100	Dr. A. Madhumathi	V-SPARC
	16697	Prof. Dipika M	V-SPARC
	14502	Prof. Meenakshi Pappu	V-SPARC
Resource Person Name	<ol style="list-style-type: none">1. Dr. Masa Noguchi, Associate Professor, The University of Melbourne, Victoria, Australia, ZEMCH Network – Founding Coordinator2. Dr. Kheira Anissa Tabet Aoul, Professor and Chair, Architectural Engineering Department, UAE3. Ar. Yatin Pandya, Architect, Researcher, Author, FOOTPRINTS E.A.R.T.H, India4. Prof. Rajan Rawal, Professor, Building Energy Performance, Faculty of Technology, CEPT University5. Dr. Shaila Bantanur, Professor and Director, BMS School of Architecture, Bengaluru6. Dr. Jun Tae Kim, Professor, Kongju National University, Republic of Korea7. Dr. S. Ghosh, Visiting Professor, SMEC, VIT		

Signature of the Coordinator

Signature of the Dean / Director

Director,
School of Architecture
Vellore Institute of Technology (VIT)
Deemed to be University under section 3 of the UGC Act 1956
Vellore – 632 014

Brochure / Circular of the Event / Programme Schedule

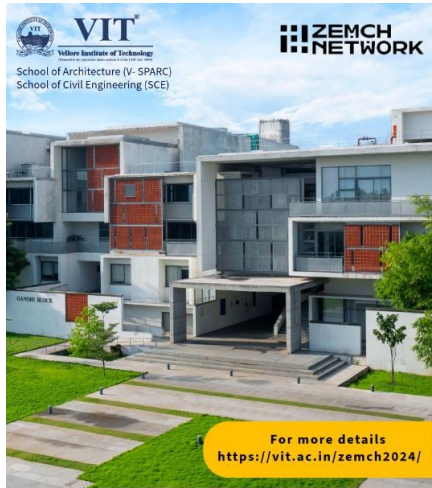

ZEMCH 2024

11th Zero Energy Mass Custom Home International Conference

8th & 9th November 2024



All accepted and presented papers will be submitted to the IOP Conference Series: Earth and Environmental Science for their peer review. Selected Papers will be published. More Scopus & SCI Journals details will be updated soon.

THEMES

Theme 1: Sustainable Neighborhood

Subthemes: Innovative Urban Planning and Design Strategies, Resilience and Climate Adaptation Approaches, Solutions for Social Equity and Inclusion, Public Health and Well-being Interventions, Environmental Conservation Techniques, Green Space Preservation and Optimization, Water Management and Conservation Practices, High Performance Green Infrastructure Development, Sustainable Transportation Solutions, Sustainable Landscaping Methods

Theme 2: Sustainable Housing

Subthemes: Energy Efficiency and Optimization, Passive Solar Design Strategies, Net-zero and Regenerative Homes, Affordable Housing, Indoor Air Quality and Health Centric Design, Site Selection and Sustainable Planning, Adaptive and Resilient Housing Smart Home Innovations, Universal Design for Inclusivity, Building Certifications and Standards

Theme 3: Building Construction Technologies

Subthemes: Sustainable Materials, Sustainable Construction Practices, Energy Efficiency Technologies, Renewable Energy Integration, Water Efficiency Technologies, Waste Reduction and Recycling, Resilience and Disaster Mitigation Technologies, Circular Economy Practices, Nano Technology, Low Embodied Energy Materials

Theme 4: Digital Technologies for Sustainability

Subthemes: Climate Modeling and Prediction, Artificial Intelligence, Building Management Systems, Digital visualization and Building Simulation Digital Twins, Smart Cities and Urban Planning, Intelligent Transportation Systems (ITS) & EV, Green Finance and Investment Blockchain and Sustainability, Environmental Monitoring and Conservation

Theme 5: Environmental Experiential Design

Subthemes: Human Factors (HF) and Ergonomics, User Experience (UX) design, Sensory and Immersive Experiences, Biophilic Design, Interactive Digital Platforms, Interactive Art and Technology, Data-Driven Design, Cultural sensitivity and Inclusivity, User Safety and Accessibility, Ethical Considerations in Design

Theme 6: Mass Customization

Subthemes: Modular Housing Solutions, Building Prefabrication, Customized Interior Design, Tailored Building Components and 3D Printing, Affordable Customization, Waste Reduction and Customization, Housing Prototypes, Adaptive Reuse and Customization, Regulatory and Ethical Considerations, Eco-friendly Materials for Mass Customization

About Vellore Institute of Technology (VIT)

VIT aims for top-notch higher education, continually innovating to meet global standards. Its diverse campus fosters excellence, supported by experienced faculty. Collaborations with international universities enhance research and student exchanges. VIT's students excel globally, embodying its commitment to excellence.

About VIT - School of Architecture (V-SPARC)

V-SPARC School of Architecture strives to be a centre of excellence in Architectural planning Education and Research focused towards evolving socially sensitive individuals equipped with design and technology process and realization skills to contribute responsibly to the changing needs of the natural and built environment.

About School of Civil Engineering (SCE)

SCE is a part of the institute since its inception. The school has grown tremendously over the past thirty years and is now recognized as one of the major engineering schools in VIT. Engineering and Technology are ranked within the top 12 in India and top 450 in the world as per QS World University Rankings by Subject 2021.

ABOUT ZEMCH NETWORK

ZEMCH Network was established with the aim to enhance industry-academia R&D collaborations on the delivery of zero energy mass custom homes in developed and developing countries. Therefore, anyone who is related to construction business and research is welcome to join the network with no annual fees.

ABOUT ZEMCH CONFERENCE 2024

11th Zero Energy Mass Custom Home International Conference, a gathering of minds dedicated to ushering in the next phase of sustainable living.

The purpose of this conference is to discover the next generation of revolutionary approaches and cutting-edge technologies that will reinvent the fundamental core of sustainable design and building.

VISION

Our focus is on zero energy mass customization, where energy efficiency effortlessly integrates with personalized living spaces that not only preserve resources but also reflect the specific preferences and demands of its occupants.

MISSION

Exploration: Investigate cutting-edge approaches that challenge traditional perspectives.

Tailored Living: Discover how technology, design, and imagination come together to create homes that are as unique as their residents.

Global Collaboration: Unite minds, transcending borders to advance sustainable housing for a greener, more resilient future.

REGISTRATION FEES

	NATIONAL	INTERNATIONAL
AUTHOR/PRESENTER	RS 9800	300 USD
DELEGATE/CO-AUTHOR	RS 7800	250 USD
STUDENTS	RS 5800	220 USD

IMPORTANT DATES

- Call for Abstracts Opens : **23rd December 2023**
- Abstract Submission Deadline : **25th March 2024**
- Abstract Review Notification : **1st April 2024**
- Paper Submission Deadline : **31st May 2024**
- Paper Review Notification : **30th June 2024**
- Registration Opens : **30th June 2024**
- Final Paper Submission Deadline : **16th August 2024**
- Registration Closes : **14th October 2024**
- Conference Dates : **8th - 9th November 2024**

ABSTRACT SUBMISSION

Mail us the Abstract at- zemch2024@vit.ac.in

WORKSHOP

5-Day Workshop on Zero Energy Mass Custom Home
For more details visit [website](https://www.vit.ac.in/zemch2024)



CONFERENCE COMMITTEE

CHIEF PATRON

Dr. G.Viswanathan, Chancellor, VIT

PATRONS

Shri. Sankar Viswanathan, Vice President, VIT
Dr. Sekar Viswanathan, Vice President, VIT
Dr. G.V.Selvam, Vice President, VIT

CO-PATRONS

Dr. V. S. Kanchana Bhaaskaran, Vice-Chancellor, VIT
Dr. Partha Sharathi Mallick, Pro-Vice Chancellor, VIT
Dr. Jayabharathi T, Registrar, VIT

CONVENORS

Dr. Madhumathi A, Director, School of Architecture, VIT
Dr. Santhi A.S, Dean, School of Civil Engineering, VIT

CONFERENCE CHAIR

Dr. Masa Noguchi CEng CEnv CTPD MIED MRAIC, Associate Professor in Environmental Design, Faculty of Architecture, Building and Planning The University of Melbourne, Victoria Australia

CO-CONVENORS

Prof. Zahra Yasmoon, Assistant Professor, School of Architecture, VIT
Dr. Nina Lazar, Assistant Professor, School of Architecture, VIT
Prof. Sushanth SJ, Assistant Professor, School of Architecture, VIT

CONFERENCE COORDINATORS

Prof. Chandrasekaran C, Professor, School of Architecture, VIT
Prof. Piyush Das, Assistant Professor, School of Architecture, VIT
Dr. Prasanna Venkatesan R, Associate Professor, School of Civil Engineering, VIT

CONTACT INFO

1. Prof Chandrasekaran C - chandrasekaran.c@vit.ac.in
2. Prof Zahra Yasmoon - zahra.yasmoon@vit.ac.in
3. Prof Piyush Das - piyush.das@vit.ac.in
4. Dr Nina Lazar - nina.lazar@vit.ac.in
5. Prof Sushanth SJ - sushanth.sj@vit.ac.in

School of Architecture, VSPARC
VIT, Vellore Campus Tiruvallam Road, Katpadi
Vellore, Tamil Nadu-632014

Email:
zemch2024@vit.ac.in

Call:
044 4627 7555

KEYNOTE SPEAKERS

 Dr. Masa Noguchi Associate Professor The University of Melbourne, Victoria, Australia Zemch Network - Founding Coordinator	 Dr. Kheira Anissa Tabet Aouf Professor and Chair Architectural Engineering Department United Arab Emirates University, UAE	 Ar. Yatin Pandya Architect, Researcher, Author FOOTPRINTS EARTH, India
 Prof. Rajan Rawal Professor Building Energy Performance Faculty of Technology, CEPT University Senior Advisor, CEPT	 Dr. Shaila Bantamur Professor and Director BMS School of Architecture, Bengaluru, India	 Dr. S Ghosh FIBRES Visiting Professor, SMEC VIT Visiting Researcher, SEE University of Leeds UK
 Dr. Jun Tae Kim Professor Kongju National University, Republic of Korea	 Dr. Veronica Soebarto Professor School of Architecture and Civil Engineering Theme Leader, Sustainable Future The University of Adelaide	

PANELISTS

- 1) **Dr. Sajal Chowdhury**
Associate Professor, D/o Architecture CUET, Bangladesh, Founding Director (Bangladesh Chapter): ZEMCH EXD Network
- 2) **Dr. Chithra K**
Associate Professor, Dept. of Architecture and Planning, NIT Calicut, Kerala
- 3) **Dr. Iyer Vijayalaxmi Kasinath**
Professor, Dept. of Architecture, School of Planning and Architecture Vijayawada
- 4) **Dr. Jeesh Venmarath**
BE (Civil), Chartered Engineer, MIE, FIV, Founder and Mentor of C-DISC Technologies LLP
- 5) **Dr. Deepa Parekh**
Sustainability Education Expert, Principal - Sustainability, Kapadia Associates, Mumbai, Maharashtra, India



VIT[®]

Vellore Institute of Technology

(Approved for its University status under section 3 of the UCAA Act, 1984)

*The students, staff, faculty and management
cordially invite you to the inaugural function of*

**11th ZERO ENERGY MASS CUSTOM HOME
INTERNATIONAL CONFERENCE 2024**

8th and 9th November 2024

Dr. G.S. Sameeran, IAS.,

Managing Director, Tamil Nadu Housing Board

will be the Chief Guest

Mr. Niranjan Kamath

*Senior Technical Solutions Executive,
Autodesk*

will be the Guest of Honour

Dr. G. Viswanathan

Founder and Chancellor

will preside.

Date : 8th November 2024 (Friday)

Time : 9.30 A.M.

Venue : Era Chezhiyan Auditorium, Gandhi Block, VIT

VIT - A Place to Learn; A Chance to Grow

**11th International Zero Energy Mass Custom Home International Conference 2024
Inauguration Programme Schedule**

Date: 8th November 2024

Time: 10.00 am

Venue: Era Sezhiyan Auditorium,
Gandhi Block, VIT

10.00 am	Invocation	Ms. Saindhavei, student, 2022 batch, V-SPARC
10.02 am	Welcome Address	Dr. A. Madhumathi, Convenor, ZEMCH Conference
10.04 am	About the Conference	Dr. Masa Noguchi , ZEMCH Network Global Coordinator
10.10 am	Honouring the Guests	
10.15 am	Felicitation	Dr. T. Jayabarathi , Registrar Dr. Partha Sharathi Mallick , Pro Vice Chancellor Dr. V S Kanchana Bhaaskaran , Vice Chancellor Ms. Kadhambari S. Viswanathan , Assistant Vice President, VIT Dr. Sandhya Pentareddy , Executive Director Dr. Sekar Viswanathan , Vice President, VIT Mr. Sankar Viswanathan , Vice President, VIT
10.30 am	Introduction of Guest of Honour	Prof. Zahra Yasmoon, Assistant Professor, V-SPARC
10.32 am	Address by Guest of Honour	Mr. Niranjan Kamath , Senior Technical Solutions Executive, Autodesk
10.40 am	Conference Logo release	
10.42 am	Presidential Address by	Dr. G. Viswanathan , Founder and Chancellor, VIT
10.55 am	Introduction of Chief Guest	Dr. Nina Lazar, Co-Convenor, ZEMCH Conference
10.57 am	Inaugural address by Chief Guest	Dr. G.S. Sameeran , IAS., Managing Director, Tamil Nadu Housing Board
11.10 am	Vote of thanks	Dr. Santhi AS, Convenor, ZEMCH Conference
Group Photo on Stage		
Masters of Ceremony: Ms. Sneha Devaraju & Mr. Gaurav R		

11th International Zero Energy Mass Custom Home International Conference 2024
Valedictory Schedule

Date: 9th November 2024

Time: 5.00 pm

Venue: Era Sezhiyan Auditorium,
Gandhi Block, VIT

5.00 pm	Welcome Address	Dr. Santhi AS, Convenor, ZEMCH Conference
5.02 pm	Conference Report	Dr. Nina Lazar, Co-Convenor, ZEMCH Conference
5.10 pm	Honouring the Guests	Dr. Masa Noguchi to Chief Guest Dr. Madhumathi A to Guest of Honour
5.20 pm	Introduction of Guest of Honour	Dr. Prasanna Venkatesan R, Co-Convenor, ZEMCH Conference
5.22 pm	Address by Guest of Honour	Dr. Kheira Anissa Tabet Aoul , Professor, United Arab Emirates University, United Arab Emirates
5.30 pm	Best Paper Award Certificate	Chief Guest (3 themes) Guest of Honour (3 themes)
	GRIHA Competition Prize Winners Announcement	MC
	Resource Person Certificates for Mr. Vimal	Chief Guest
	Autodesk Design Challenge	Chief Guest and Guest of Honour
	Logo Design Competition	Chief Guest and Guest of Honour
	Certificate for Conference Chair	Chief Guest and Guest of Honour
	Certificates for Convenor and Co-Convenor	Dr. Masa Noguchi
	Certificates for Conference Coordinators (Faculty of V-SPARC) – Certificate on the stage and photoshoot	
5.50 pm	Introduction of Chief Guest	Prof. Sushanth SJ, Co-Convenor, ZEMCH Conference
5.52 pm	Valedictory address by Chief Guest	Ar. T.R. Palaniappan , Vice Chairman, IIA Tamil Nadu Chapter
6.00 pm	Vote of thanks	Prof. Chandrasekaran C., Coordinator, ZEMCH Conference
6.02 pm	National Anthem	Ms. Saindhavei, student, 2022 batch, V-SPARC
Masters of Ceremony: Ms. Sneha Devaraju & Mr. Gaurav R		

Panel Discussion mementos – end of panel discussion by Dr. Madhumathi

Best Paper Award Certificate – Chief Guest and Guest of Honour

1. Sustainable Neighbourhood:
2. Sustainable Housing:
3. Building Construction Technologies:
4. Digital Technologies for Sustainability:

5. Environmental Experience Design:
6. Mass Customization:

A) GRIHA Competition Prize Winners:

Winner: Ar. Rahul Shrikhande, Rahul Shrikhande and Associates – Project: Breathing House

Special Mention 1: Ar. Yogesh Chandrahasan, Principal Architect, WeBe Design Lab – Project: LinBrick House

Special Mention 2: Ar. Sriram Ramakrishnan, Principal Architect, FHD, Bangalore – Project: Polycab Experience Centre

Resource Person Certificates for Mr. Vimal – Chief Guest

B) Autodesk Design Challenge – Certificate distribution from Dr. Masa

1st Prize: Project ‘SAPlings’ by Ms. Sneha Devaraju, Mr. Prajwal, Mr. Aaron Geo Sam and Mr. Sambram

2nd Prize: Project ‘ECONEST’ by Ms. Safreena Roshan

Special Mention: Project ‘Civilians’ by Mr. Avaneesh M, Mr. Piyush Raj, Ms. Athidharani K V, Mr. Yaswanth Pavan

Certificate for Conference Chair **Dr. Masa Noguchi** – by Chief Guest and Guest of Honour

C) Certificates for Convenor and Co-Convenor – by Dr. Masa

Convenor: Dr. A. Madhumathi, Director, VIT School of Architecture

Convenor: Dr. Shanthi AS, Dean, School of Civil Engineering

Co-convenors: Prof. Dr. Nina Lazar, Assistant Professor, VIT School of Architecture

Prof. Zahra Yasmoon, Assistant Professor, VIT School of Architecture

Prof. Sushanth SJ, Assistant Professor, VIT School of Architecture

Dr. Prasanna Venkatesan R, Assistant Professor, VIT School of Architecture

Certificates for Conference Coordinators (Faculty of V-SPARC) – Certificate on the stage and photoshoot

Group photo: Arcause Team

Conference Team (faculty+students)

11th ZEMCH International Conference 2024 – A Report

The 11th Zero Energy Mass Custom Home (ZEMCH) International Conference was successfully held on the 8th and 9th of November 2024 at Vellore Institute of Technology (VIT), Vellore. Organized by the School of Architecture (V-SPARC) and the School of Civil Engineering (SCE), in collaboration with the ZEMCH Network, the event brought together global experts from academia and industry to discuss advancements in sustainable housing and construction technologies.

The conference focused on six major themes: Sustainable Neighborhoods, Sustainable Housing, Building Construction Technologies, Digital Technologies for Sustainability, Environmental Experiential Design, and Mass Customization. Keynote speakers included Dr. Masa Noguchi, Prof. Rajan Rawal, Dr. Veronica Soebarto, and other eminent professionals who shared valuable insights on zero-energy design and mass customization strategies.

Ahead of the main conference, a 5-day workshop on Zero Energy Mass Custom Homes was conducted, enriching the learning experience for participants. Accepted papers were published in the IOP Conference Series: Earth and Environmental Science, indexed in Scopus.

ZEMCH 2024 provided a dynamic platform for knowledge exchange and collaboration, highlighting innovative, inclusive, and future-ready approaches for sustainable living. The event marked a significant step forward in uniting global minds toward resilient and energy-efficient built environments.

Expenditure / Revenue Details of the Event

1	Revenue from the Event	1401038
2	Revenue from Registration	1020982
3	Revenue from others	380056

Expenditure for ZEMCH 2024 @ V-SPARC, VIT - Vellore		
S. No.	Description	Amount
1	Logo Competition	11,080
2	Griha	40,120
3	Stalls	48,380
4	Workshop	80,476
5	Registration	10,20,982
6	Sponsorship - Autodesk	1,70,000
7	Autodesk Workshop Prize Money	30,000
Total		14,01,038



Signature of the Coordinator



Signature of the Dean / Director

Director,
School of Architecture
Vellore Institute of Technology (VIT)
Deemed to be University under section 3 of the UGC Act 1956
Vellore – 632 014



School of Electrical Engineering

WORKSHOP DETAILS

Event type	WORKSHOP		
Title of the event	2-day Hands on workshop on POWER AND ENERGY SIMULATION SOFTWARE with AI TECHNIQUES PESSAIT-2024		
Date (From – To)	17-18, October 2024		
Time	09:00 PM to 05:00 PM		
Venue	TT237		
No. of Participants	24		
Coordinator(s)	Emp. ID.	Faculty Name	Department
	11815	Dr RAVI K	DEE
	10510	DR. PRABHAKAR KARTHIGEYAN	DEE
#1 Resource Person Name			
Designation	R & D HEADS		
Organization Details	Er.Sivakumar and Er Ragunath. Power project india Chennai.		
Place	CHENNAI		
E-mail	sivakumpowerprject@gmail.com		
Mobile no.	9942688763		

Signature of the Coordinator

Signature of the Dean / Director

Brochure / Circular of the Event / Programme Schedule

<p>Resource Person</p> <p>All technical sessions will be handled by experts from power projects India, Chennai.</p> <p>Topics To be Covered</p> <ul style="list-style-type: none"> Modelling and TOV study Introduction about Insulation Co-ordination Modelling of Bus, Grid, Transmission line, Transmission line equivalent circuit, Ferranti effect Simulation Power factor correction and Reactive Power Compensation Short circuit study Renewable energy integration Power quality studies Simulation study and hands on training using Power system Computer Aided Design (PSCAD/EMTP) Role of AI in power and energy sector <p>Registration Process</p> <ul style="list-style-type: none"> Prospective participants are requested to register for the workshop through the following web link. Certificate will be issued to all registered participants. Attendance is mandatory for all sessions. <p>Registration Fees (Excluding GST)</p> <ul style="list-style-type: none"> External Faculty/ Industry Experts Rs. 1250 Internal Faculty Rs. 1000 Students / Research Scholars Rs. 750 <p>Registration fees include workshop kit, 2 day working lunch and high tea.</p> <p>Important Dates</p> <p>Last date for registration 16th Oct 2024</p>	<p>Organizing Committee</p> <p>Chief Patron</p> <p>Dr. G. Viswanathan, Chancellor</p> <p>Patrons</p> <p>Mr. Sankar Viswanathan, Vice President Dr. Sekar Viswanathan, Vice President Dr. G. V. Selvam, Vice President Dr. V. S. Kanchana Bhaaskaran Vice Chancellor Dr. Partha Sharathi Mallick, Pro-VC Dr. T. Jayabarathi, Registrar</p> <p>Organizing Chair</p> <p>Dr. Mathew Mithra Noel, Professor (HAG) & Dean School of Electrical Engineering</p> <p>Dr. N. Amutha Prabha, Professor & Assoc. Dean School of Electrical Engineering</p> <p>Organizing Co-Chairs</p> <p>Dr. K. Sathish Kumar Professor & HOD (EEE), School of Electrical Engineering</p> <p>Conveners</p> <p>Dr. K. Ravi, Professor, School of Electrical Engineering, VIT, Vellore +91-9486940357, k.ravi@vit.ac.in</p> <p>Dr. K. Sathish kumar, Professor, School of Electrical Engineering, VIT, Vellore ksathishkumar@vit.ac.in</p> <p>Dr. Prabhakar Karthigeeyan, Professor School of Electrical Engineering, VIT, Vellore +91-9894610689, sprabhakararthikeya@vit.ac.in</p>	 <p>2-day Hands on workshop on POWER AND ENERGY SIMULATION SOFTWARE with AI TECHNIQUES</p> <p>PESSAIT-2024</p> <p>17-18, October 2024</p>  <p>Organizing in association with Power projects India</p>   <p>Organized by Department of Electrical Engineering School of Electrical Engineering VIT, Vellore –632 014</p>
--	---	--

<p>About the Institution</p> <p>VIT was established with the aim of providing quality higher education on par with international standards. It persistently seeks and adopts innovative methods to improve the quality of higher education on a consistent basis. The campus has a cosmopolitan atmosphere with students from all corners of the globe. Experienced and learned teachers are strongly encouraged to nurture the students. The global standards set at VIT in the field of teaching and research spur us on in our relentless pursuit of excellence. In fact, it has become a way of life for us. The highly motivated youngsters on the campus are a constant source of pride. Our Memoranda of Understanding with various international universities are our major strength. They provide for an exchange of students and faculty and encourage joint research projects for the mutual benefit of these universities. Many of our students, who pursue their research projects in foreign universities, bring high quality to their work and esteem to India and have done us proud. With steady steps, we continue our march forward. We look forward to meeting you here at VIT.</p> <p>About School of Electrical Engineering</p> <p>The School of Electrical Engineering (SELECT) has over 93 faculty members who pursued their UG, PG and Doctoral degrees from top-notch universities. The faculty members are consistently performing well in teaching and research. Faculty members and students frequently receive awards, laurels and prizes for outstanding research contributions in their respective fields.</p> <p>The school offers 3 B.Tech. programmes (Electrical and Electronics Engineering, Electrical and Computer Science Engineering and Electronics and Instrumentation Engineering), and 2 M.Tech. programmes (Power Electronics and Drives & Control and Automation), Ph.D and Integrated Ph.D in Engineering. Both B.Tech. and M.Tech. programmes attract the Intelligent students from the country and abroad. The B.Tech. Electrical and</p>	<p>Electronics Engineering and B.Tech. Electronics and Instrumentation Engineering Programmes are accredited by the Engineering Accreditation Commission of ABET. All UG & PG programmes of the school are accredited by the Institution of Engineering and Technology (IET), U.K.</p> <p>The placement record of the school has always been impressive. Almost 100% of the students secure job from the campus placement and many of them are recruited in core companies. We encourage our students to carry out industry based projects during their B.Tech and M.Tech degrees. The School has state-of-the art laboratories in almost all the areas of Electrical, Electronics and Instrumentation Engineering. The School has the latest simulation tools to cater various specializations and is equipped with facilities for measurement, characterization and synthesis of experimental as well as theoretical results. SELECT has industry sponsored advanced laboratories for performing world class research and consultancy. Danfoss Advance Drives Lab, Schneider Electric Smart Energy Monitoring Lab, Fluke Testing and Calibration Lab, Q-Max Automated Test Engineering Lab (Alumni Sponsored Lab) and NxP Semiconductors, India, have established Centre of Excellence for students R&D activities under the guidance of faculty members and industry experts.</p> <p>The students are encouraged to take advantage of the growing opportunities by incorporating an international internship experience in their final year undergraduate and postgraduate education. Students are also motivated to opt twin degree program with various reputed universities across the globe. Every year, students get scholarships to do their final year projects abroad under the Semester Abroad Program (SAP).</p> <p>About Workshop</p> <p>The basic objective of this 2-day workshop is to impart knowledge on the power and energy related simulation software with AI tools focusing on load flow study, stability analysis, short circuit study and renewable energy, microgrid and transient analysis studies etc.</p>	<p>As power systems evolve, the need for accurate, intuitive simulation tools becomes more and more important. With PSCAD you can build, simulate, and model your systems with ease, providing limitless possibilities in power system simulation. Included is a comprehensive library of system models ranging from simple passive elements and control functions to electric machines and other complex devices.</p> <p>PSCAD has benefited from over 40 years of continuous research and development. We are inspired by the ideas and feedback from our global user base. This philosophy has helped establish PSCAD as the most popular power system transient simulation package available today.</p> <p>Artificial Intelligence (AI) has emerged as a crucial technology for the future of industries and infrastructure. This workshop discusses the impact of AI on the power system network, with a particular focus on the different steady state and transient study. Interconnection of large-scale Inverter Based Resource (IBR) such as wind parks (WP) and photovoltaic parks (PV) into the bulk power system has become a more important issue due to their significant impact on power system transient behavior. These models will be focused as black box models and their usage using EMTP.</p> 
---	--	--

REPORT RELATED to 2-Day workshop on POWER AND ENERGY SIMULATION SOFTWARE with AI TECHNIQUES PESSAIT-2024

Er Sivakumar and Er Raghunath delivered a lecture in the following topics for 2-Day workshop on “POWER AND ENERGY SIMULATION SOFTWARE with AI TECHNIQUES -PESSAIT-2024” to be held during 17-18, October-2024.



SCHOOL OF ELECTRICAL ENGINEERING

2-day Hands on workshop on “POWER AND ENERGY SIMULATION SOFTWARE with AI TECHNIQUES -PESSAIT-2024” to be held during 17-18, October 2024.

VENUE- TT247

DAY 1- 17-10-2024

Time	Topic	Resource person
8:15 am – 9:45 am	Registration, Technology Tower Purvico	
09:45 am- 11.30 am	Introduction about Power System Introduction about Load Flow Analysis with IEEE 3002-2 and IEEE 399	Er.Sivakumar Power project india Chennai.
11.30 am-11.45 am	High Tea	
11.45 am -1.00 am	“Modelling of Bus, Grid, Transmission line, Transmission line equivalent circuit, Ferranti effect Simulation with manual calculation”	Er.Raghunath Power project india Chennai
01:00 pm-02.00 pm	Lunch	
02.15 pm -03.15 pm	“Transformer paralleling, transformer losses, Transformer OLTC Selection”	Er.Sivakumar Power project india Chennai.
03:15 pm – 03:30 pm	High Tea	
03:30 pm – 05.00 pm	Power factor correction and Reactive Power Compensation	Er.Sivakumar Power project india Chennai

DAY 2 - 18-10-2024

Time	Topic	Resource person
09.30 am- 11.30 am	“Modelling and TOV study Introduction about Insulation Co- ordination”	Er.Sivakumar Power project india Chennai.
11.30 am-11.45 am	High Tea	
11.45 am -1.00 am	Modelling of Source, Cable and Transmission line	Er.Raghunath Power project india Chennai
01:00 pm-02.00 pm	Lunch	
02.15 pm -03.15 pm	Load and Transformer Modelling	Er.Raghunath Power project india Chennai
03:15 pm – 03:30 pm	High Tea	
03:30 pm – 05.00 pm	Temporary Overvoltage Study	Er.Sivakumar Power project india Chennai.
05.00pm- 05.15 pm	Vote of thanks	Dr.Prabhakararathigayam Professor VIT Vellore

Signature of the Coordinator

Signature of the Dean / Director

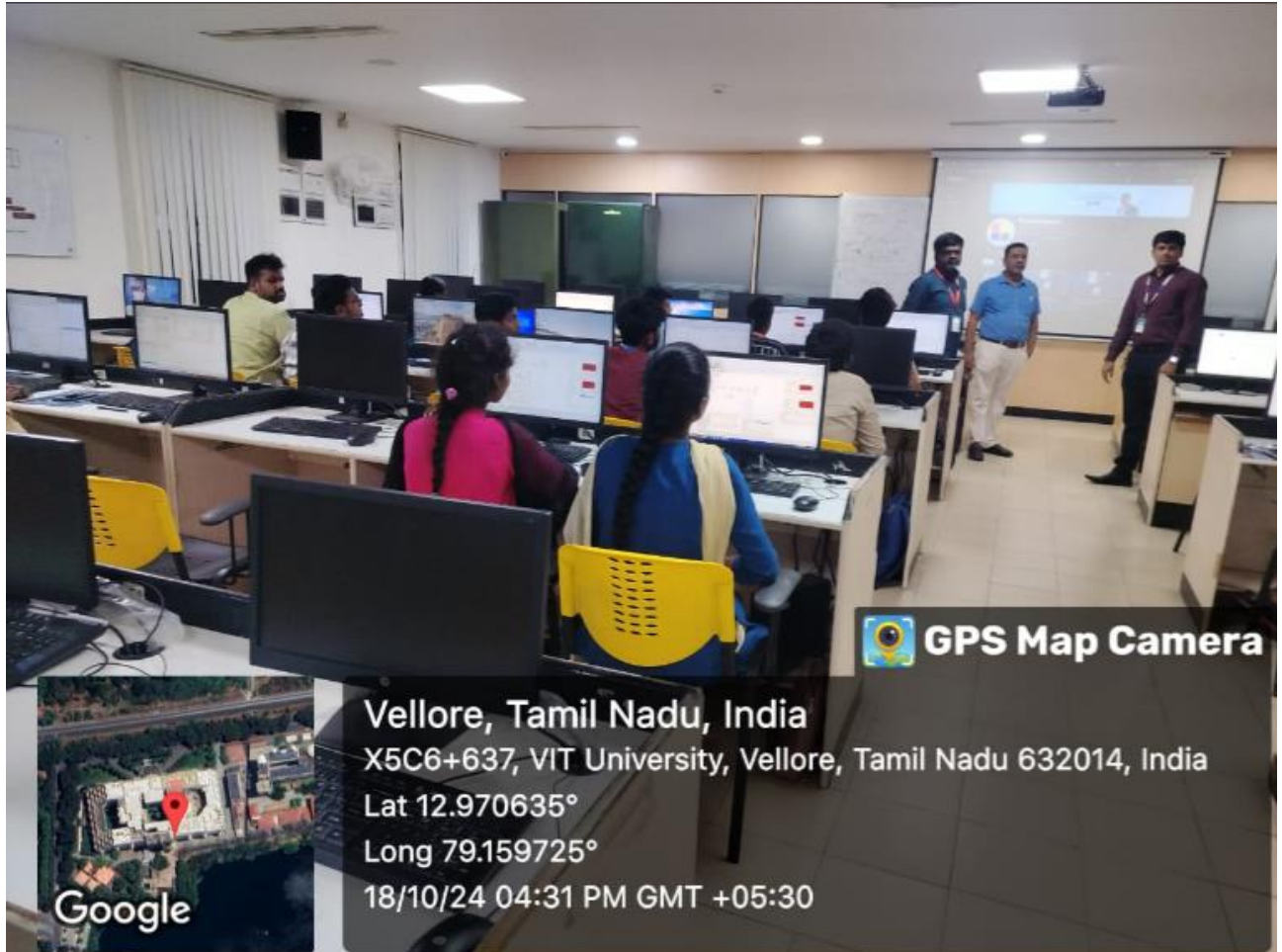



 **GPS Map Camera**

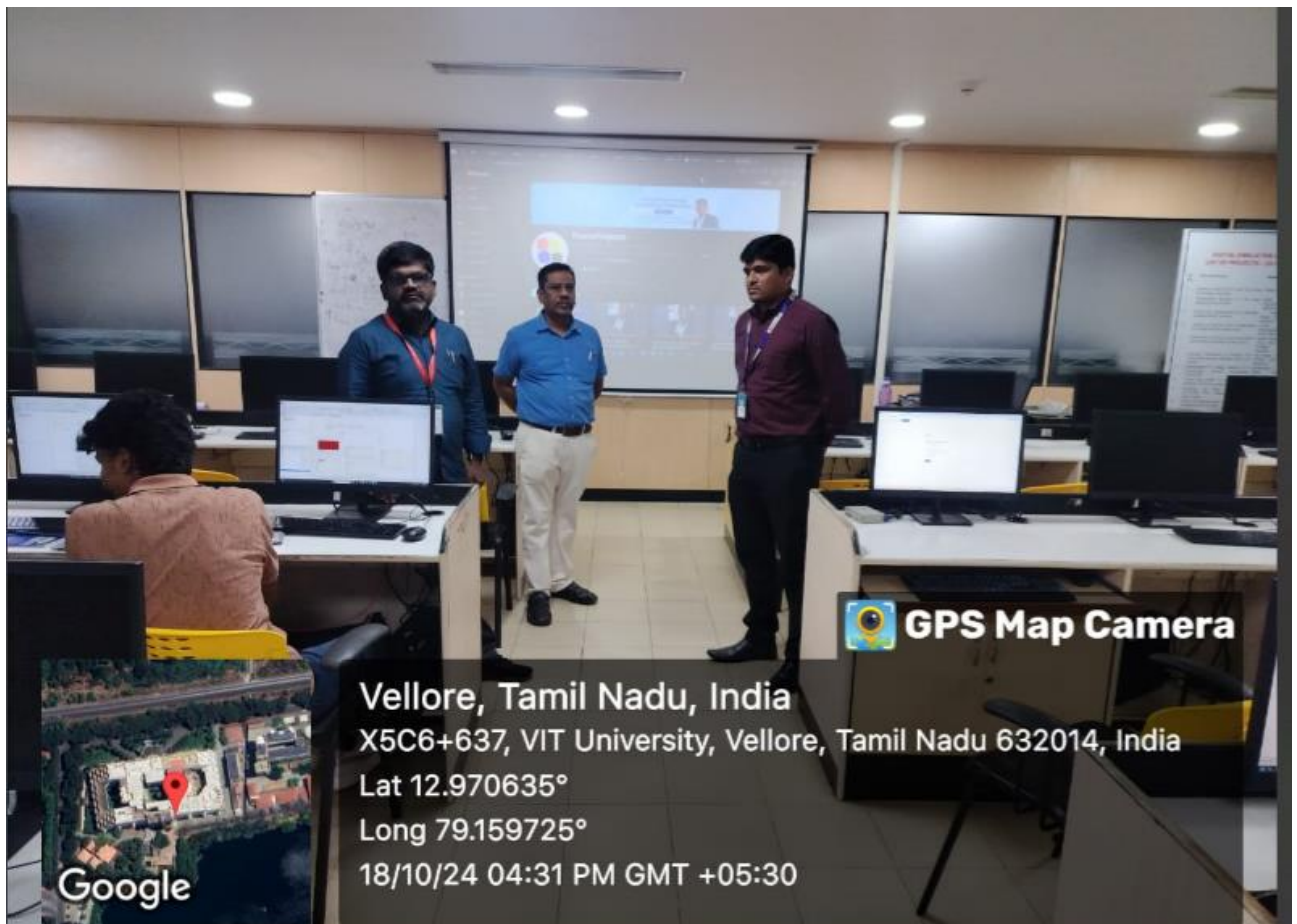

Vellore, Tamil Nadu, India
X5C6+637, VIT University, Vellore, Tamil Nadu 632014, India
Lat 12.970635°
Long 79.159725°
18/10/24 04:31 PM GMT +05:30

Google



 **GPS Map Camera**



Vellore, Tamil Nadu, India
X5C6+637, VIT University, Vellore, Tamil Nadu 632014, India
Lat 12.970635°
Long 79.159725°
18/10/24 04:31 PM GMT +05:30

Google

Remuneration /claim form

My General Claimed Reimbursement - Finance Department - 2024-2025

Emp ID/Staff Code:	11815	Name:	Dr. Ravi K		
Designation:	Professor Grade 2	School / Centre:	SELECT		
Date of Joining:	11/02/2009				
Mobile No:	9486940357	Email ID:	k.ravi@vit.ac.in		
Bank A/C Details:	Indian Bank	VIT Branch	823757307		
General Reimbursement #:		42787	Submitted On:		08/11/2024
Event Date	17/10/2024	Purpose of visit	Organized a 2-day Hands on workshop on #CoPOWER AND ENERGY SIMULATION SOFTWARE with AI TECHNIQUES -PESSAIT-2024@VIT to be held during 17-18, October 2024.		
Journey Details		Date	Place	Time	
From		17/10/2024	ERODE	5.00AM	
To		18/10/2024	VIT VELLORE	6.00PM	
Recipient Member (1) - Bank Details					
Recipient's Full Name		RAGHUNATH	Account No		1691101022608
Bank Name	CANARA BANK		IFSC Code		CNR00001691
PAN No	CVQPS7630P				
Amount Details					
2.	Travel			877	
3.	Accommodation			0	
5.	Remuneration			5000	
8.	Others			0	
	Total			5877	
Claim Details of General Reimbursement					
Sl.No	Claim Title		Claimed Amount		
1.	Travel Claim with Bill (Restricted to 2 nd A/C train fare)		877		
2.	Accommodation		0		
3.	Remuneration Fee		5000		
4.	Other Fee		0		
	Claimed Total		5877		



Signature of the Coordinator



Signature of the Dean / Director

1. Does your institution provide mandatory annual dedicated training on environmental aspects of sustainability for staff members (faculty and professional staff members) and students?

Energy on the move: Distributed wind power for a sustainable future

Date: 02 Sept 2024

Description:

The workshop titled “Energy on the Move: Distributed Wind Power for a Sustainable Future” was conducted on 2nd September 2024 by the School of Electrical Engineering (SELECT) in an offline mode, bringing together 45 participants including students, faculty, and external attendees. The event focused on exploring the potential of distributed wind power as a sustainable energy solution, with expert speakers from academia and industry sharing their insights. The sessions introduced participants to the fundamentals of distributed versus centralized wind systems, emphasizing their relevance in rural electrification, clean energy access, and community empowerment.

The workshop further delved into technological advancements in wind turbine design, energy integration challenges, and the role of energy storage in ensuring reliability. Key discussions also covered sustainability aspects, policy frameworks, and real-world case studies demonstrating successful implementations of distributed wind systems. Participants gained valuable interdisciplinary knowledge, while the interactive sessions, panel discussions, and Q&A fostered collaboration and idea exchange among researchers and industry professionals. Overall, the event successfully enhanced awareness and encouraged innovation in the field of sustainable wind energy solutions.

Event Photos:



National Workshop on AI and Environmental Sustainability

Date: 21 Sep 2024

Description:

The National Workshop on AI and Environmental Sustainability was a technical event organised as part of TechnoVIT 2024 under the school event Vitness. The workshop took place on 21/09/2024 from 09:00 AM to 1:00 PM at VOC Auditorium, Admin Block, VIT Chennai, with a total of 243 participants from both internal and external backgrounds. The workshop highlighted AI's transformative role in addressing environmental challenges and adopted a contemporary perspective. Resource persons were invited from diverse backgrounds to explore the following topics: introduction to AI for environmental awareness, AI for waste management and circular economy optimisation, AI for disaster resilience management, AI for environmental monitoring and sustainable agriculture, AI-driven energy efficiency, and legal and ethical issues in AI for environmental sustainability.

After the invocation, the event commenced with the lighting of Kuthu Vilaku. The welcome address was delivered by Dr. M. S. Sharmila, Associate Professor, VITSOL. The chief guest, guests of honour, and resource persons were then felicitated. The event was addressed by the guest of honour, Tmt. Sudha S., IFS., Member Secretary, State Planning Commission, and the chief guest, APMJ Sheikh Dawood, Co-Founder, APMJ International Foundation. Subsequently, the resource persons — Vetriselvan, Advocate, Madras High Court, and Dr. J. Senophiyah Mary, Indian Green Service Director — addressed the event respectively. The event concluded with a valedictory function, and all participants were provided with certificates.

Event Photos:



Online International Conference on Optimizing Climate Justice through Technological Interventions

Date: 21 Sep 2024

Description:

The International Conference on Climate Change, Sustainable Technology, and Policy Frameworks brought together a diverse community of academics, researchers, professionals, and students to foster multidisciplinary dialogue on one of the most pressing global challenges of our time. Rooted in the need to align technological innovation with effective policy governance, the conference served as a platform for exchanging ideas on sustainable technologies, regulatory frameworks, renewable energy, carbon capture, and community engagement in climate action. The event drew remarkable international participation, receiving around 200 abstracts and proposals from across India — spanning all regions from North to South — as well as contributions from nations including Italy, Dubai, and Sri Lanka.

The conference achieved its expected outcomes with distinction. Eminent guests of honour, including former Vice Chancellors, former Advocate Generals, and distinguished academicians from institutions across India and abroad, delivered valuable insights to the gathering. Ten technical sessions were chaired by resource persons from leading national and international institutions such as Nagaland Central University, Delhi University, Leiden University (The Netherlands), and institutions from the United Kingdom, with ten in-house faculty from VITSOL serving as co-chairpersons. Paper presentations were made by a wide spectrum of participants — engineers, public prosecutors, research scholars, and students — from Central Universities, State Universities, INIs like Rashtriya Raksha University, and private institutions. The conference concluded with the release of a Book of Abstracts, marking a meaningful step toward advancing knowledge and action on climate resilience and sustainable development.

Event Photos:



FDP on Clean Energy Technologies for Sustainable Development

Date: 30 Sep - 04 Oct 2024

Description:

The FDP spanned over a week and covered multiple facets of clean energy technologies and their implications for sustainable development. The sessions were conducted by experts from academia, industry, and research institutions. The topics covered included renewable energy sources, energy efficiency, Self-Powered Smart Textiles: Energy-Generating Fabrics for the Future, Developments & Future Directions in Clean Energy Applications, Carbon neutral powertrain solutions for sustainable automotive applications, Introduction to environmental sustainability, Sustainability and Life cycle assessment in packaging sector.

The FDP successfully enhanced participants' knowledge of cutting-edge clean energy technologies, including smart textiles and carbon-neutral automotive solutions. Faculty members were encouraged to incorporate these topics into their curricula and pursue research collaborations. The program inspired educators to contribute to sustainable development through innovative teaching and research. In conclusion, the FDP provided valuable insights into the future of clean energy, equipping faculty members to advance sustainability efforts in their academic and research endeavours.

Event Photos:

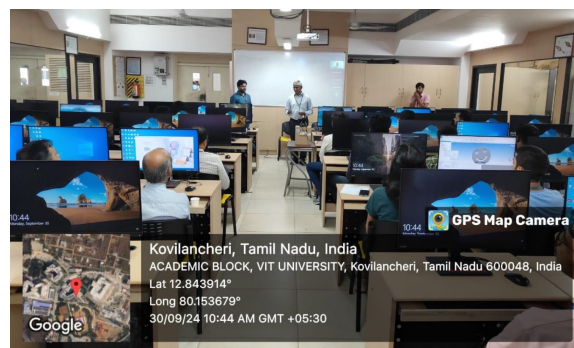
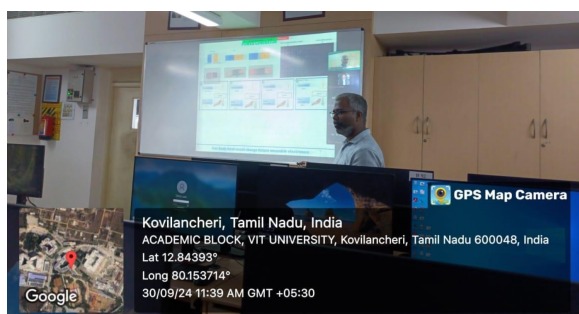

Hackathon on Sustainability in ClimaTech

Date: 09-10 Oct 2024

Description:

ClimaTech INNOVATE was a 24-hour hackathon that brought together students, developers, and tech enthusiasts to develop innovative solutions in the domain of climate technology. The event aimed to encourage participants to apply technology to real-world challenges, fostering creativity, teamwork, and problem-solving, with a focus on sustainability, climate change, and related issues.

The hackathon kicked off on Day 1 with a registration and welcome ceremony at 11:30 AM, followed by an introduction to the theme and a briefing on the phases and deadlines. Teams began brainstorming and coding at noon, with a progress check conducted at 4:00 PM. On Day 2, participants moved into full implementation mode, with a second progress check used to filter the top 6 teams for the final round. The qualified teams then presented their projects — covering key features, tech stacks, and solutions — before faculty coordinators evaluated them. The event concluded with a valedictory function at 11:30 AM, where the top three teams were announced and celebrated.

Event Photos:

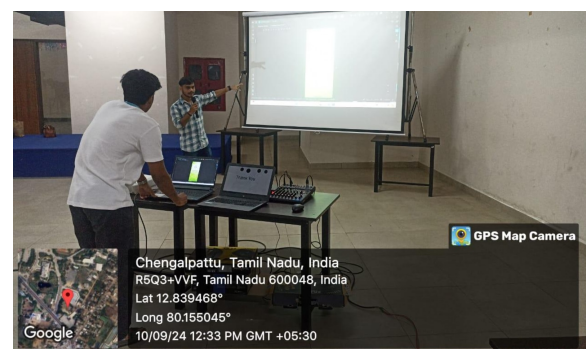

Hackathon on Sustainability in ClimaTech

Date: 09-10 Oct 2024

Description:

ClimaTech INNOVATE was a 24-hour hackathon that brought together students, developers, and tech enthusiasts to develop innovative solutions in the domain of climate technology. The event aimed to encourage participants to apply technology to real-world challenges, fostering creativity, teamwork, and problem-solving, with a focus on sustainability, climate change, and related issues.

The hackathon kicked off on Day 1 with a registration and welcome ceremony at 11:30 AM, followed by an introduction to the theme and a briefing on the phases and deadlines. Teams began brainstorming and coding at noon, with a progress check conducted at 4:00 PM. On Day 2, participants moved into full implementation mode, with a second progress check used to filter the top 6 teams for the final round. The qualified teams then presented their projects — covering key features, tech stacks, and solutions — before faculty coordinators evaluated them. The event concluded with a valedictory function at 11:30 AM, where the top three teams were announced and celebrated.

Event Photos:

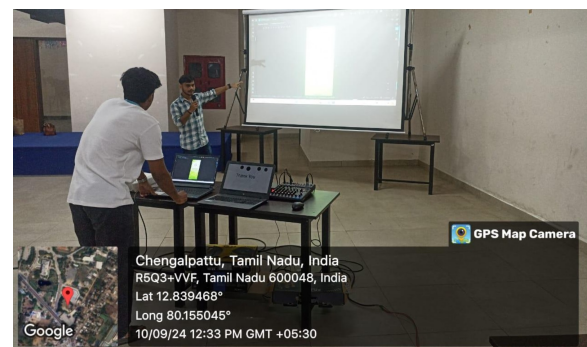

Fourth International Conference on Sustainable Energy Solutions for a Better Tomorrow

Date: 09-11 Jan 2025

Description:

The main objective of this International Conference on Sustainable Energy Solutions for a Better Tomorrow (SESBT 2025) is to provide a platform to researchers and practitioners from both academic institutions and industries to meet and share cutting-edge developments in the areas of sustainable energy and associated disciplines. This conference provided an opportunity to exchange research evidence and innovative ideas and also the challenges in achieving sustainable energy. SESBT 2025 included presentations on the latest research on Carbon Neutrality, Electric & Hybrid Vehicles, Green & Energy Efficient Buildings, Energy Storage, Computational Models for Energy Systems, Advanced Cryo Techniques, Thermal System Optimization and Renewable Energy. This conference also gathered an excellent group of keynote speakers from around the globe who shared their latest research findings among the above mentioned conference themes.

Event Photos:



International Conference on Advancements in AI and ML for Sustainable Engineering (AIML) - iMechcon 2025

Date: 09-11 Jan 2025

Description:

The three-day International Conference on Emerging Materials for Energy and Sustainability (EMES-2025), hosted at VIT Chennai's Netaji Auditorium from January 9–11, 2025, featured an impressive lineup of plenary and keynote speakers addressing cutting-edge topics in sustainable technologies. Day 1 highlighted energy storage materials, hydrogen initiatives, AI in semiconductors, and desalination, with speakers like Dr. Ted Steinberg (QUT, Australia), Dr. P.V. Aravind (Netherlands), and Mr. Venkatesh Duraisamy (Western Digital, India). Day 2 covered AI/IoT for circular economies, natural fiber composites, and heat stress mitigation, featuring Dr. Michael Short (Teesside University, UK) and Prof. Dr.-Ing. Daniel Schilberg (Germany), while Day 3 focused on thermoelectric tech, green hydrogen, and smart grids with experts like Dr. Mohd Faizul Bin Mohd Sabri (Universiti Malaya) and Prof. S. Vasudevan (CSIR, India).

Sessions blended physical and online presentations, including sponsor specials from TWI, fostering global dialogue on renewables, energy efficiency, and eco-materials. The event successfully united researchers, industry leaders, and academics, sparking collaborations and insights into practical sustainability solutions across energy storage, clean manufacturing, and environmental engineering.

Event Photos:



International Conference on Emerging Materials for Energy and Sustainability (EMES 2025)

Date: 06 - 08 Feb 2025

Description:

Advanced materials are pivotal for sustainability, enhancing energy efficiency, storage, and renewables through innovations like catalysts for clean fuel via water splitting, nanomaterials for pollutant removal, solid-state electrolytes for batteries, perovskite solar cells, quantum dots, MOFs/COFs for hydrogen storage and carbon capture, and biodegradable polymers for eco-electronics. Thermoelectric and piezoelectric materials further enable waste heat recovery and energy harvesting, addressing environmental challenges across sectors.

The Department of Chemistry, School of Advanced Sciences at Vellore Institute of Technology, Chennai, hosted the inaugural three-day International Conference on Emerging Materials for Energy and Sustainability (EMES-2025) from February 6–8, 2025, supported by ANRF, CSIR, and sponsors like Royal Society of Chemistry. Gathering global experts, it fostered research collaborations, industry partnerships, and impactful discussions, concluding successfully with gratitude to participants and plans for future editions.

Event Photos:



Greenathon 2025 – A Tech & Sustainability Ideathon

Date: 27-Mar-2025

Description:

Greenathon 2025 encourages innovative solutions for environmental safety through cutting-edge technology. The event promotes AI, IoT, and blockchain applications in sustainability while supporting student startups with funding and incubation opportunities.

Key Highlights:

- Internship offers in IoT, DevOps, and Cloud
- INR 2,00,000 funding under the Student Startup Venture Scheme
- Incubation facilities at V-NEST
- E-Participation certificates for all attendees

Event Photos:

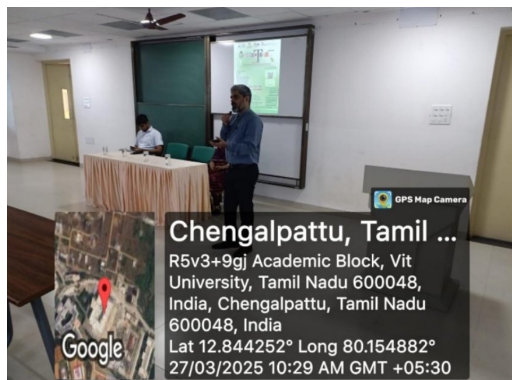

Classroom to Climate Action: Engineering for Impact

Date: 04 Apr 2025

Description:

The guest lecture was conducted as part of VIT Chennai's academic enrichment initiative to expose students to global challenges and innovations in civil engineering. Titled "Classroom to Climate Action: Engineering for Impact," the lecture was held online on April 4th, 2025, and was specifically organized for third-year B.Tech students to deepen their understanding of how civil engineering can contribute to addressing climate change through sustainable practices. The session focused on sustainable construction materials, low-carbon cement systems, and their role in enhancing climate resilience. It emphasized the urgent need to shift from conventional construction techniques to more environmentally responsible alternatives, highlighting current research developments, industry trends, and practical applications.

Key topics included pozzolanic and sybio-pozzolanic composites, hydrophobic powders for improving durability and reducing the carbon footprint of cementitious materials, and the use of Response Surface Methodology (RSM) for optimizing material performance. The speaker also discussed global sustainability frameworks, green building policies, and the vital role of civil engineers in achieving environmental goals. The lecture concluded with an engaging Q&A session, where students actively interacted with the speaker, asking insightful questions on the challenges, feasibility, and research scope in sustainable construction. The session was well-received, with students appreciating its depth, relevance, and real-world applicability.

The guest lecture served as a valuable knowledge-sharing platform, connecting academic concepts with global environmental goals. It not only enriched the students' understanding of sustainable construction but also encouraged them to adopt environmentally responsible approaches in their future careers.

Event Photos:

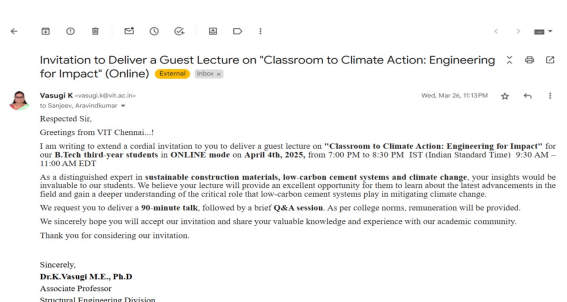
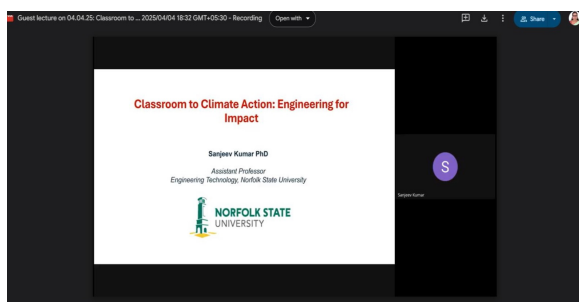

Carbon capture utilisation and storage and decarbonation of hard to abate industries

Date: 11 Mar 2025

Description:

The Climate Compatible Growth (CCG) is a UK FCDO funded research programme which is helping countries in the Global South to take a path of low carbon development while simultaneously unlocking profitable investment in green infrastructure. The National Partnerships team of the CCG is led by the Centre for Global Equality (CGE). The CCCDM, Anna University is the National Partner for coordinating the activities of the CCG programme. The core theme of the CCG programme is through the Special Interest Groups (SIGs) which are Sustainable Energy Transition, Climate Circular Economy and Climate Resilient Cities. As part of this effort, the recent launch event of the Special Interest Group on Sustainable Energy Transition identified key thematic areas for developing policy briefs. One such critical area is Carbon Capture, Utilization, and Storage (CCUS) and the Decarbonization of Hard-to-Abate Industries. To advance discussions on this topic, a workshop was conducted at VIT Chennai on 11th March 2025 (Tuesday), bringing together experts, researchers, and policymakers to deliberate and formulate a comprehensive policy brief. The workshop was attended by 40 participants, including research scholars, faculty members, representatives from NGOs, and industry professionals.

Event Photos:



