

## Important Dates

Prospective participants are requested to register for through the following link.

**Link for registration:**  
<https://events.vit.ac.in/>

**Last date for registration: 25-03-2026**

**Registration Fee: Rs 750/-**

## Modules to be covered

- Simulation in manufacturing: Introduction to manufacturing; Recent advancements in manufacturing, Classification, Importance of simulation in manufacturing, Simulation Tools used in manufacturing.
- Simulation aspects in machining: FE Model development, Meshing, Element selection, Loading and boundary conditions for machining simulation, Thermal analysis in machining, Case studies, Demonstration
- Simulation aspects in metal forming: Introduction to metal forming, Bulk metal and sheet metal forming, Uni-axial deformation simulation, Incremental forming simulation. Simulation in Limit dome height, Ring rolling, tube drawing processes, Demonstration
- Welding Simulation: Introduction to welding simulation, Tools used for welding simulation, Boundary conditions and material properties selection, Pre and post processing, Weld pool simulation.
- Thermal analysis and distortion simulation in welding: Heat flow in welding, Weld thermal cycle, Temperature measurement in welding, Thermal analysis of welding, Thermo-Mechanical analysis, Distortion in weld joints, Prediction of distortion in welding.
- Role of residual stresses: Residual stresses, Types of residual stresses, Significance of residual stresses, Residual stress formation mechanism, Measurement methods. Residual stresses in various manufacturing processes, Simulation of residual stresses
- Contemporary discussion: Case studies and demonstration

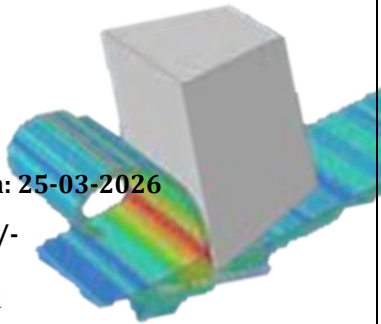

## Chief Patron

**Dr. G. Viswanathan** Founder & Chancellor

## Patrons

**Dr. Sankar Viswanathan** Vice President

**Dr. Sekar Viswanathan** Vice President

**Dr. G. V. Selvam** Vice President

## Co-Patrons

**Dr. Kanchana Bhaaskaran V.S** Vice Chancellor

**Dr. Partha Sharathi Mallick** Pro-Vice-Chancellor

**Dr. T. Jayabarathi** Registrar

## Convenor

**Dr. P. Kuppan** Dean-SMEC

## Co – Convenors

**Dr. Rajyalakshmi G** HOD, Manufacturing Engineering

**Dr. JOSE S** HOD, Thermal & Energy Engineering

**Dr. M Manikandan** HOD, Design & Automation

**Dr. N Govindha Rasu** HOD, Automotive Engineering

## Coordinators

**Dr. Jambeswar Sahu** +91-9937583191,

[jambeswar.sahu@vit.ac.in](mailto:jambeswar.sahu@vit.ac.in)

**Dr. Anoj Giri.** +91-7417642987,

[anoj.giri@vit.ac.in](mailto:anoj.giri@vit.ac.in)

**Dr. Atul Kumar,** +91-8394880897

[atul.kumar@vit.ac.in](mailto:atul.kumar@vit.ac.in)



# VIT<sup>®</sup>

Vellore Institute of Technology  
(Deemed to be University under section 3 of UGC Act, 1956)

**Value added course on**

## VAC2349: Modelling and Simulation in Manufacturing

**March 25 to April 10, 2026**

## Resource Persons

Dr. Shivraman, NIT Warangal

Dr. Oomar, TVS Chennai

Dr. Jeet Patil, SGGS IE&T Nanded

Dr. Pravendra Singh, IITM (Post Doc)

Dr. Suya Prem Anand, VIT Vellore

Dr. Bikash Rout, VIT Vellore

Dr. Yazar K U, VIT Vellore

Dr. Vivek Kumar Barnwal, VIT Vellore

Dr. Atul Kumar, VIT Vellore

Dr. Anoj Giri, VIT Vellore

Dr. Jambeswar Sahu, VIT Vellore

**Organized by**  
**School of Mechanical Engineering**  
**VIT, Vellore -632 014**

## About the Vellore Institute of Technology

Vellore Institute of Technology was founded in 1984 as Vellore Engineering College by the Founder and Chancellor Dr. G.Viswanathan. University status was conferred in 2001 by MHRD Govt. of India in recognition of its excellence in academics, research and extracurricular initiatives.

### Ranking & Accreditation

Vellore Institute of Technology (VIT) has emerged as one of the best institutes of India and is aspiring to become a global leader. Quality in teaching-learning, research and innovation makes VIT unique.

- ❖ Engineering and Technology: 142nd in the World and 9th in India (QS World University Rankings by Subject 2025)
- ❖ Data Science and AI subject areas are within the Top 100 in the world. Computer Science, Information Systems, Electrical, Electronics, Material Science subject areas are within the top 200 in the world (QS World University Rankings by Subject 2025)
- ❖ Within the top 2 in India and top 600 in the world (Shanghai ARWU ranking 2025)
- ❖ NAAC Accreditation with A++ grade (3.66 out of 4)
- ❖ Within the top 20 in University, Research and Engineering categories in India (NIRF Ranking, Govt. of India 2025)
- ❖ 396th in the world and 8th in India ( QS World University Rankings : Sustainability 2025)



## School of Mechanical Engineering (SMEC)

The School of Mechanical Engineering is one of the oldest and most prestigious schools of VIT. This school started functioning right from 1984, the year in which our institution began. The School of Mechanical Engineering offers 3 undergraduate and 6 post-graduate programs. The school has a team of highly qualified faculty members, many holding PhDs from elite institutes across the globe, to teach and train this country's best minds. The pride of the school lies in the significant research funding received from several National and International agencies such as DST, DRDO, MNRE, CSIT, CVRDE, CPDO, IE, AR&DB, BRNS, ISRO, UGC, NRB, Royal Academy of Engineering etc.

The Department of Science and Technology, Govt. of India has recognized the school for its research activities and supported in 2003, 2010 and 2022 under the FIST scheme and 2020 under PURSE. The school has modern facilities, enabling cutting-edge research in a wide spectrum of niche technological areas. Mechanical, Aeronautical & Manufacturing is ranked within 201-250 in the World (India Rank 9-10) as per QS World University Rankings by Subject 2025.

### Course Objectives

- Demonstrate scope of simulation in manufacturing process
- Develop detailed understanding about Finite element analysis and application to manufacturing process.
- Describe residual stress & distortion aspects in manufacturing and its simulation
- Understanding of simulation and application using various packages.

### Program Schedule

<b>25/03/2026</b> <b>Dr. Jambeswar Sahu</b> (6.00 PM-08:30 PM)	<b>Introduction to manufacturing, Simulation Tools used in manufacturing.</b>
<b>26/03/2026</b> <b>Dr. Oomar</b> (6.00 PM-08:30 PM)	<b>FE Analysis, Machining simulation, Demonstration</b>
<b>27/03/2026</b> <b>Dr. Suya Prem Anand</b> (6.00 PM-08:30 PM)	<b>Modelling of machining processes</b>
<b>28/03/2026</b> <b>Dr. Bikash Rout</b> (6.00 PM-08:30 PM)	<b>Machining Simulation</b>
<b>30/03/2026</b> <b>Dr. Vivek Baranwal</b> (6.00 PM-08:30 PM)	<b>Metal forming, Incremental forming simulation</b>
<b>31/03/2026</b> <b>Dr. Jeet Patil</b> (11.00 AM-1.00 PM)	<b>Thermoforming</b>
<b>01/04/2026</b> <b>Dr. Pravendra Singh</b> (6.00 PM-08:30 PM)	<b>Thermo-Mechanical analysis</b>
<b>02/04/2026</b> <b>Dr. Shivraman</b> (6.00 PM-08:30 PM)	<b>Heat flow in welding</b>
<b>04/04/2026</b> <b>Dr. Anoj Giri</b> (6.00 PM-08:30 PM)	<b>Thermal analysis of welding, Prediction</b>
<b>06/04/2026</b> <b>Dr. Anoj Giri</b> (11.00 AM-1.00 PM)	<b>Residual stresses measurement methods, Simulation of residual stresses.</b>
<b>07/04/2026</b> <b>Dr. Atul Kumar</b> (6.00 PM-08:30 PM)	<b>Distortion in weld joints</b>
<b>08/04/2026</b> <b>Dr. Yazar K U</b> (6.00 PM-08:30 PM)	<b>Additive Manufacturing Simulation</b>
<b>09/04/2026</b> (6.00 PM-08:30 PM)	<b>Assessment</b>